Interfacing the 93XX76 and 93XX86 to a PIC16C5X

INTRODUCTION

Microchip's newest offerings in the 3-wire Serial EEPROM family are the 93XX76 and 93XX86 devices. These are 8k-bit and 16k-bit versions of our 93 series Serial EEPROMs with a couple of differences from the standard 93XX46, 93XX56 and 93XX66 devices:

1. These devices have a Program Enable (PE) pin, which is used as a hardware write protect. Tying the PE pin to VCC enables the array to be written to, while tying it to Vss prohibits the array from being written to. There is an internal pull-up resistor on the PE pin that allows the array to be written to when there is no connection to the PE pin.
2. The internal write cycle begins on the rising edge of the last data bit (D0) for the 93XX76 and 93XX86 devices, where the existing 93XX46, 93XX56 and 93XX66 devices begin their internal write cycle on the falling edge of Chip Select (CS) after the last data bit has been sent. Software written for the 93XX46, 93XX56 and 93XX66 devices will still be compatible, however the internal write cycle will begin slightly earlier on the new 93XX76 and 93XX86 devices. The only changes to the code required are the number of address bits necessary to access the larger memory arrays.

The code that is written for this application note was taken from AN560 and the only modifications were the number of address bits output. Please refer to AN560 for more details about the original code. If the reader is new to Serial EEPROMs, please refer to application note AN536 for a more basic tutorial. This application note is intended to provide the engineer with stand-alone code modules for accomplishing all of the necessary functions required to utilize these devices in an application. See Figure 1 for a schematic of how the PIC16C54 was connected to the 93XX76 and 93XX86.

Although these devices are called 3-wire devices, they have essentially 4 I/O pins:

CS	Chip Select
CLK	Clock
DI	Data In
DO	Data Out

These devices use a series of commands to accomplish standard memory functions. These are READ, WRITE, EWEN, ERASE, ERAL, WRAL, EWDS. These functions are discussed in more detail in the datasheets for any of the 93 series devices.

The following programs are included in this application note and are fully functional stand-alone modules. The source code for these modules can be downloaded from the Microchip BBS. They are located in the MEM_APPS file library as one zipped up file, AN619.zip. Please consult page 8-1 of the *1995/1996 Non-Volatile Memory Products Data Book* or page 6-3 of the *1995/1996 Embedded Control Handbook Update* for more information on how to use the Microchip BBS.

The following are the programs included in this application note, along with the subroutines they call:

Byte Read Program (7686byrd.asm)

- Start Bit Routine
- Bin In Routine
- Receive Data routine
- Bit Out Routine
- Transmit Data Routine
- Power-up Routine

Byte Write Program (7686bywr.asm)

- Delay Routine
- Start Bit Routine
- Bit Out Routine
- Transmit Data Routine
- Power-up Routine
- Erase/Write Enable Routine (EWEN)
- Byte Write Routine
- Erase/Write Disable Routine (EWDS)

Byte Write with Data Polling Program (7686dpol.asm)

- Data Polling Delay Routine
- Start Bit Routine
- Bit Out Routine
- Transmit Data Routine
- Power-up Routine
- Erase/Write Enable Routine (EWEN)
- Write Routine
- Erase/WRite Disable Routine (EWDS)

AN619

Sequential Read Program (7686seqr.asm)

- Delay Routine
- Start Bit Routine
- Bit In Routine
- Receive Data Routine
- Bit Out Routine
- Transmit Data Routine
- Power-up Routine
- Read Routine

FIGURE 1: CONNECTION BETWEEN PIC16C54 AND 93XX76/86 SERIAL EEPROM

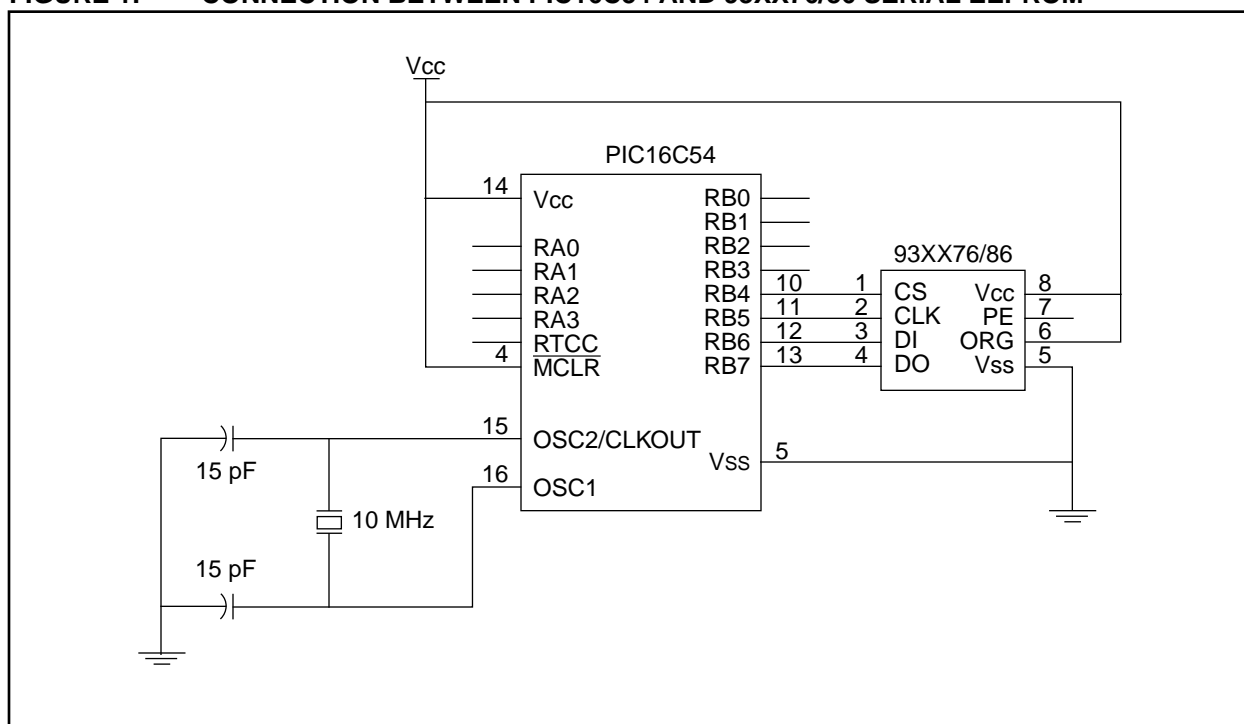

NOTES:

WORLDWIDE SALES & SERVICE

AMERICAS

Corporate Office

Microchip Technology Inc.
2355 West Chandler Blvd.
Chandler, AZ 85224-6199
Tel: 602 786-7200 Fax: 602 786-7277
Technical Support: 602 786-7627
Web: <http://www.mchip.com/microchip>

Atlanta

Microchip Technology Inc.
500 Sugar Mill Road, Suite 200B
Atlanta, GA 30350
Tel: 770 640-0034 Fax: 770 640-0307

Boston

Microchip Technology Inc.
5 Mount Royal Avenue
Marlborough, MA 01752
Tel: 508 480-9990 Fax: 508 480-8575

Chicago

Microchip Technology Inc.
333 Pierce Road, Suite 180
Itasca, IL 60143
Tel: 708 285-0071 Fax: 708 285-0075

Dallas

Microchip Technology Inc.
14651 Dallas Parkway, Suite 816
Dallas, TX 75240-8809
Tel: 214 991-7177 Fax: 214 991-8588

Dayton

Microchip Technology Inc.
35 Rockridge Road
Englewood, OH 45322
Tel: 513 832-2543 Fax: 513 832-2841

Los Angeles

Microchip Technology Inc.
18201 Von Karman, Suite 455
Irvine, CA 92715
Tel: 714 263-1888 Fax: 714 263-1338

New York

Microchip Technology Inc.
150 Motor Parkway, Suite 416
Hauppauge, NY 11788
Tel: 516 273-5305 Fax: 516 273-5335

San Jose

Microchip Technology Inc.
2107 North First Street, Suite 590
San Jose, CA 95131
Tel: 408 436-7950 Fax: 408 436-7955

ASIA/PACIFIC

Hong Kong

Microchip Technology
Unit No. 3002-3004, Tower 1
Metroplaza
223 Hing Fong Road
Kwai Fong, N.T. Hong Kong
Tel: 852 2 401 1200 Fax: 852 2 401 3431

Korea

Microchip Technology
168-1, Youngbo Bldg. 3 Floor
Samsung-Dong, Kangnam-Ku,
Seoul, Korea
Tel: 82 2 554 7200 Fax: 82 2 558 5934

Singapore

Microchip Technology
200 Middle Road
#10-03 Prime Centre
Singapore 188980
Tel: 65 334 8870 Fax: 65 334 8850

Taiwan

Microchip Technology
10F-1C 207
Tung Hua North Road
Taipei, Taiwan, ROC
Tel: 886 2 717 7175 Fax: 886 2 545 0139

EUROPE

United Kingdom

Arizona Microchip Technology Ltd.
Unit 6, The Courtyard
Meadow Bank, Furlong Road
Bourne End, Buckinghamshire SL8 5AJ
Tel: 44 0 1628 851077 Fax: 44 0 1628 850259

France

Arizona Microchip Technology SARL
2 Rue du Buisson aux Fraises
91300 Massy - France
Tel: 33 1 69 53 63 20 Fax: 33 1 69 30 90 79

Germany

Arizona Microchip Technology GmbH
Gustav-Heinemann-Ring 125
D-81739 Muenchen, Germany
Tel: 49 89 627 144 0 Fax: 49 89 627 144 44

Italy

Arizona Microchip Technology SRL
Centro Direzionale Colleoni
Palazzo Pegaso Ingresso No. 2
Via Paracelso 23, 20041
Agrate Brianza (MI) Italy
Tel: 39 039 689 9939 Fax: 39 039 689 9883

JAPAN

Microchip Technology Intl. Inc.
Benex S-1 6F
3-18-20, Shin Yokohama
Kohoku-Ku, Yokohama
Kanagawa 222 Japan
Tel: 81 45 471 6166 Fax: 81 45 471 6122

9/22/95



Printed in the USA, 9/95
© 1995, Microchip Technology Inc.

"Information contained in this publication regarding device applications and the like is intended through suggestion only and may be superseded by updates. No representation or warranty is given and no liability is assumed by Microchip Technology Incorporated with respect to the accuracy or use of such information, or infringement of patents arising from such use or otherwise. Use of Microchip's products as critical components in life support systems is not authorized except with express written approval by Microchip. No licenses are conveyed, implicitly or otherwise, under any intellectual property rights." The Microchip logo and name are registered trademarks of Microchip Technology Inc. All rights reserved. All other trademarks mentioned herein are the property of their respective companies.