



Using Timer1 in Asynchronous Clock Mode

INTRODUCTION

This application note discusses the use of the Timer1 module, of the PIC16CXX family, for an asynchronous clock. The Timer1 module has its own oscillator circuitry, which allows the timer to keep real time, even when the device is in sleep mode. When the device is in sleep, the oscillator will continue to increment Timer1. An overflow of Timer1 causes a timer1 interrupt (if enabled) and will wake the processor from sleep. The interrupt service routine, then can do the desired task.

OVERVIEW

Timer1 is a 16-bit counter with a 2-bit prescaler. Timer1 can be incremented from either the internal clock, an external clock, or an external oscillator. Timer1 can be configured to synchronize or not synchronize the external clock sources. The asynchronous operation allows timer1 to increment when the device is in sleep. Figure 1 is a block diagram of Timer1.

To set up Timer1 for asynchronous operation the timer1 control register (T1CON) must have the following bits configured:

- TMR1CS set (external clock source)
- T1CKS<1:0> configured for the desired prescaler
- T1INSYNC set (asynchronous operation)
- TMR1ON set (enables Timer1)
- Set T1OSCEN, if using an external oscillator

In asynchronous operation, if the clock source is an external clock, the clock must be on the T1CKI pin. If the clock source is a crystal oscillator, the crystal is connected across the T1OSO and T1OSI pins. Please refer to the device Data Sheet for recommended capacitor selection for the Timer1 oscillator.

When using Timer1 in asynchronous mode, the use of an external clock minimizes the operating and sleep currents. This is because the oscillator circuitry is disabled. Though the external clock may give the lower device currents, the use of a crystal oscillator may lead to lower system current consumption and system cost.

System current consumption can also be reduced by having the timer1 overflow interrupt wake the processor from sleep at the desired interval. With a 32.768 KHz crystal, Timer1's overflow rate ranges from 2 to 16 seconds, depending on the prescaler chosen. Table 1 shows timer1 overflow times for various crystal frequencies and prescaler values.

TABLE 1: TIMER1 OVERFLOW TIMES

Prescaler	Frequency (KHz)		
	32.768	100	200
1	2 Seconds	0.655	0.327 Seconds
2	4 Seconds	1.31 Seconds	0.655 Seconds
4	8 Seconds	2.62 Seconds	1.31 Seconds
8	16 Seconds	5.24 Seconds	2.62 Seconds

FIGURE 1: TIMER1 BLOCK DIAGRAM

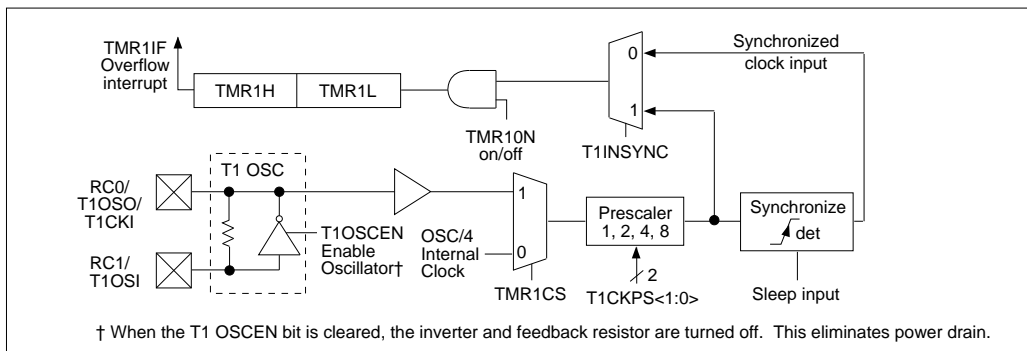

3

Using Timer1 in Asynchronous Clock Mode

As can be seen the 32 KHz crystal, gives very nice overflow rates. These crystals, referred to as watch crystals, also can be relatively inexpensive. In many applications the 2 second overflow time, of a 32 KHz crystal, is too long. An easy way to reduce the the overflow time is during the interrupt service routine, to load the TMR1H register with a value. Table 2 shows the overflow times, depending on the value loaded into the TMR1H register and a prescaler of 1.

TABLE 2: TMR1H LOAD VALUES / TIMER1 OVERFLOW TIMES

TMR1H Load Value	Overflow Time (@ 32.768 KHz)
80 h	1 Second
C0 h	0.5 Seconds
E0 h	0.25 Seconds
F0 h	0.125 Seconds

Note: The loading of either TMR1H or TMR1L causes the prescaler to be cleared. When Timer1 is in operation, extreme care should be taken in modifying either the TMR1H or TMR1L registers, since this automatically modifies the prescaler to 1.

The code segment shown in Example 1 initializes the Timer1 module for asynchronous mode, enables the Timer1 interrupt, and the interrupt service routine loads the TMR1H register with a value.

CONCLUSION

Timer1 gives designers a powerful timebase function. The asynchronous operation and oscillator circuitry gives designers the ability to easily keep real time, while minimizing power consumption and external logic.

*Author: Mark Palmer - Sr. Application Engineer
Logic Products Division*

Using Timer1 in Asynchronous Clock Mode

EXAMPLE 1: TIMER1 CODE SEGMENT FOR ASYNCHRONOUS OPERATION

```
    org    0x000
Reset_V   GOTO    START
;
    org    0x004
PER_INT_V
    BCF     STATUS, RP0    ; Bank 0
    BTFSC  PIR1, TMR1IF   ; Timer 1 overflowed?
    GOTO    T1_OVRFL      ; YES, Service the Timer1 Overflow Interrupt
;
; Should NEVER get here
;
ERROR1    ; NO, Unknown Interrupt Source
    BSF     PORTD, 1      ; Toggle a port pin to indicate error
    BCF     PORTD, 1
    GOTO    ERROR1
;
T1_OVRFL
    BCF     PIR1, TMR1IF   ; Clear Timer 1 Interrupt Flag
    MOVLW  0x80           ; Since doing key inputs, clear TMR1
    MOVWF  TMR1H          ; for 1 sec overflow.
    :
    :                   ; Do Interrupt stuff here
    :
    RETFIE                ; Return / Enable Global Interrupts
;
;
START     ; POWER_ON Reset (Beginning of program)
    CLRF   STATUS         ; Do initialization (Bank 0)
    BCF   T1CON, TMR1ON   ; Timer 1 is NOT incrementing
    :
    :                   ; Do Initialization stuff here
    :
    MOVLW 0x80           ; TIM1H:TMR1L = 0x8000 gives 1 second
    MOVWF TMR1H          ; overflow, at 32 KHz.
    CLRF  TMR1L          ;
;
    CLRF  INTCON
    CLRF  PIR1
    BSF   STATUS, RP0    ; Bank 1
    CLRF  PIE1          ; Disable all peripheral interrupts
;
    if ( C74_REV_A )
        BSF   TRISC, T1OSO ; See PIC16C74 Errata
    endif
    BSF   PIE1, TMR1IE    ; Enable TMR1 Interrupt
;
; Initialize the Special Function Registers (SFR) interrupts
;
    BCF   STATUS, RP0    ; Bank 0
    CLRF  PIR1          ;
    BSF   INTCON, PEIE   ; Enable Peripheral Interrupts
    BSF   INTCON, GIE    ; Enable all Interrupts
;
    MOVLW 0x0E
    MOVWF T1CON         ; Enable T1 Oscillator, Ext Clock, Async, prescaler = 1
    BSF   T1CON, TMR1ON ; Turn Timer 1 ON
;
zzz      SLEEP
        GOTO  zzz       ; Sleep, wait for TMR1 interrupt
```

Using Timer1 in Asynchronous Clock Mode

NOTES:

WORLDWIDE SALES & SERVICE

AMERICAS

Corporate Office

Microchip Technology Inc.
2355 West Chandler Blvd.
Chandler, AZ 85224-6199
Tel: 602 786-7200 Fax: 602 786-7277
Technical Support: 602 786-7627
Web: <http://www.mchip.com/microhip>

Atlanta

Microchip Technology Inc.
500 Sugar Mill Road, Suite 200B
Atlanta, GA 30350
Tel: 770 640-0034 Fax: 770 640-0307

Boston

Microchip Technology Inc.
5 Mount Royal Avenue
Marlborough, MA 01752
Tel: 508 480-9990 Fax: 508 480-8575

Chicago

Microchip Technology Inc.
333 Pierce Road, Suite 180
Itasca, IL 60143
Tel: 708 285-0071 Fax: 708 285-0075

Dallas

Microchip Technology Inc.
14651 Dallas Parkway, Suite 816
Dallas, TX 75240-8809
Tel: 214 991-7177 Fax: 214 991-8588

Dayton

Microchip Technology Inc.
35 Rockridge Road
Englewood, OH 45322
Tel: 513 832-2543 Fax: 513 832-2841

Los Angeles

Microchip Technology Inc.
18201 Von Karman, Suite 455
Irvine, CA 92715
Tel: 714 263-1888 Fax: 714 263-1338

New York

Microchip Technology Inc.
150 Motor Parkway, Suite 416
Hauppauge, NY 11788
Tel: 516 273-5305 Fax: 516 273-5335

AMERICAS (continued)

San Jose

Microchip Technology Inc.
2107 North First Street, Suite 590
San Jose, CA 95131
Tel: 408 436-7950 Fax: 408 436-7955

ASIA/PACIFIC

Hong Kong

Microchip Technology
Unit No. 3002-3004, Tower 1
Metroplaza
223 Hing Fong Road
Kwai Fong, N.T. Hong Kong
Tel: 852 2 401 1200 Fax: 852 2 401 3431

Korea

Microchip Technology
168-1, Youngbo Bldg. 3 Floor
Samsung-Dong, Kangnam-Ku,
Seoul, Korea
Tel: 82 2 554 7200 Fax: 82 2 558 5934

Singapore

Microchip Technology
200 Middle Road
#10-03 Prime Centre
Singapore 188980
Tel: 65 334 8870 Fax: 65 334 8850

Taiwan

Microchip Technology
10F-1C 207
Tung Hua North Road
Taipei, Taiwan, ROC
Tel: 886 2 717 7175 Fax: 886 2 545 0139

EUROPE

United Kingdom

Arizona Microchip Technology Ltd.
Unit 6, The Courtyard
Meadow Bank, Furlong Road
Bourne End, Buckinghamshire SL8 5AJ
Tel: 44 0 1628 851077 Fax: 44 0 1628 850259

France

Arizona Microchip Technology SARL
2 Rue du Buisson aux Fraises
91300 Massy - France
Tel: 33 1 69 53 63 20 Fax: 33 1 69 30 90 79

Germany

Arizona Microchip Technology GmbH
Gustav-Heinemann-Ring 125
D-81739 Muenchen, Germany
Tel: 49 89 627 144 0 Fax: 49 89 627 144 44

Italy

Arizona Microchip Technology SRL
Centro Direzionale Colleoni
Palazzo Pegaso Ingresso No. 2
Via Paracelso 23, 20041
Agrate Brianza (MI) Italy
Tel: 39 039 689 9939 Fax: 39 039 689 9883

JAPAN

Microchip Technology Intl. Inc.
Benex S-1 6F
3-18-20, Shin Yokohama
Kohoku-Ku, Yokohama
Kanagawa 222 Japan
Tel: 81 45 471 6166 Fax: 81 45 471 6122

9/22/95

All rights reserved. © 1995, Microchip Technology Incorporated, USA.

Information contained in this publication regarding device applications and the like is intended through suggestion only and may be superseded by updates. No representation or warranty is given and no liability is assumed by Microchip Technology Incorporated with respect to the accuracy or use of such information, or infringement of patents or other intellectual property rights arising from such use or otherwise. Use of Microchip's products as critical components in life support systems is not authorized except with express written approval by Microchip. No licenses are conveyed, implicitly or otherwise, under any intellectual property rights. The Microchip logo and name are registered trademarks of Microchip Technology Inc. All rights reserved. All other trademarks mentioned herein are the property of their respective companies.
