

## Implementing Ultrasonic Ranging

*Author: Robert Schreiber  
Logic Products Division*

### INTRODUCTION

Object ranging is essential in many types of systems. One of the most popular ranging techniques is ultrasonic ranging. Ultrasonic ranging is used in a wide variety of applications including:

- Auto focus cameras
- Motion detection
- Robotics guidance
- Proximity sensing
- Object ranging

This application note describes a method of interfacing PIC16CXX microcontrollers to the Polaroid 6500 Ranging Module. This implementation uses a minimum of microcontroller resources, a CCP module and two I/O pins. The two major components of the system are:

- Microcontroller
- Polaroid 6500 Ranging Module

The microcontroller performs the intelligence and arithmetic functions for ultrasonic ranging, while the Polaroid 6500 Ranging Module performs the ultrasonic signal transmissions and echo detection.

**FIGURE 1: RANGING MODULE INTERFACE**

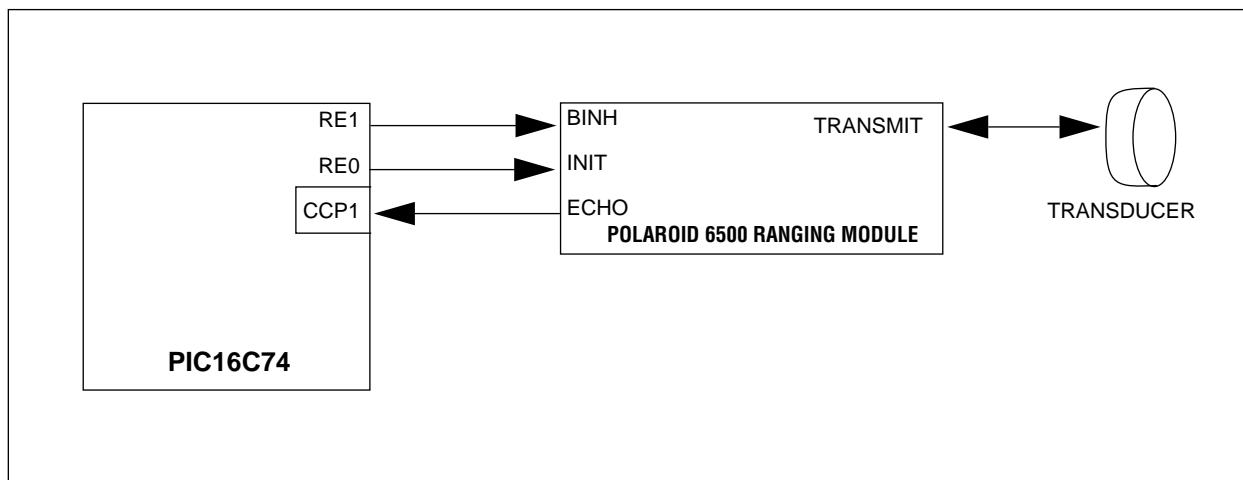

### THEORY OF OPERATION

Ultrasonic ranging entails transmitting a sound wave and measuring the time that it takes for the sound wave to reflect off of an object and back to the origin. The reflection time is proportional to the distance that the object is from the source. In this implementation, the sound wave is transmitted and received from the same transducer. Therefore, a blanking interval is required between signal transmission and reception to eliminate false echoes (i.e., a transmitted signal being detected as its own echo).

### CIRCUIT CONFIGURATION

In this implementation, a PIC16C74 is connected to the ranging module as shown in Figure 1. The RE0 and RE1 I/O pins are configured as digital outputs and are tied to INIT and BINH, respectively. The CCP1 pin is configured as a digital input and is tied to ECHO through a pull-up resistor. The pull-up resistor is needed since the ECHO signal is an open-collector output. The CCP1 pin is configured for capture mode (CCP1CON). Figure 2 shows the timing relationship for V<sub>DD</sub> and the three signal lines (INIT, BINH, and ECHO).

**Note:** The ranging module requires 5.0 milliseconds to stabilize during power-up.

**FIGURE 2: TIMING DIAGRAM OF RANGING MODULE CONTROL LINES**

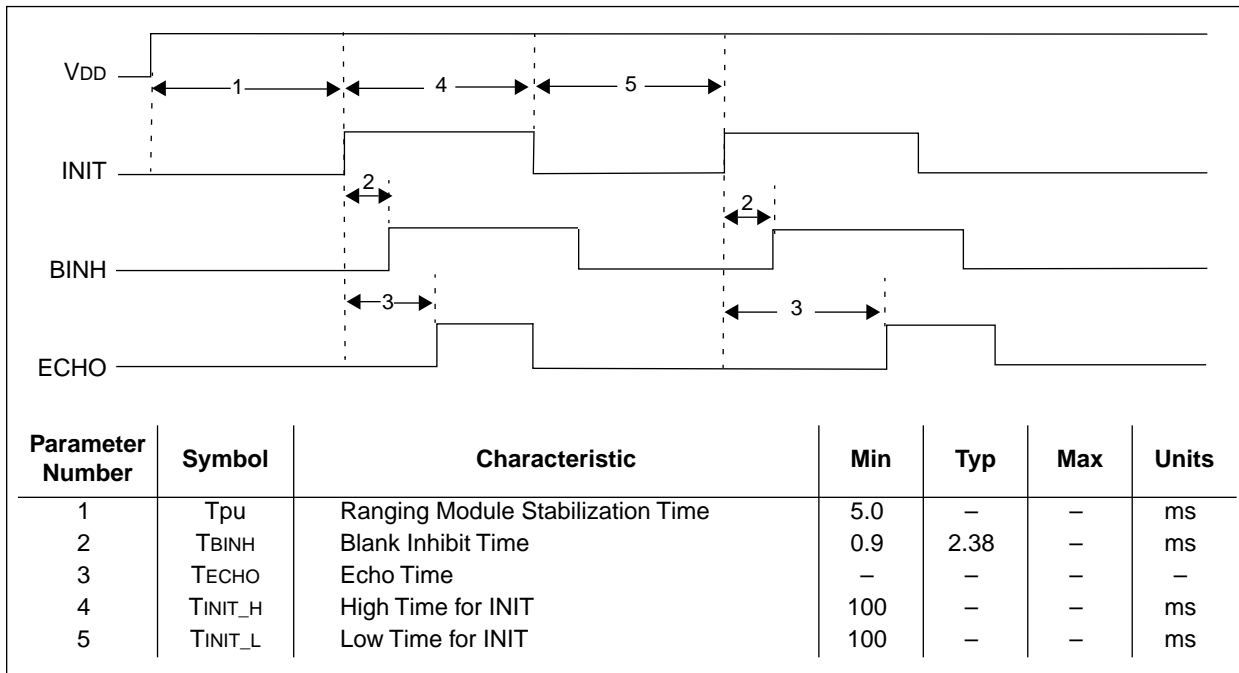

The PIC16C74 is configured to use one of its internal timers, Timer1, in capture mode to measure the time between signal transmission and echo detection. The resolution of the timer is determined by the microcontroller clock frequency. For this application, a 4 MHz external oscillator was used, giving a resolution of 1 ms per bit. The PIC16C74 initiates a ranging cycle by first clearing Timer1. Timer1 is then enabled and INIT is immediately asserted on the ranging module. When INIT is asserted, the ranging module transmits a series of 16 pulses on the transducer at 49.4 kHz. The transmitted pulses reflect off the object and are received back at the transducer.

The transducer is used for both transmitting and receiving sound waves. A blanking interval is needed to ensure that the transmitted signal has decayed on the transducer, in order not to receive false echoes. In normal operation, the ranging module has a blanking interval of 2.38 milliseconds, which corresponds to a minimum detection distance of approximately 17 inches. However, the BINH (blank inhibit) signal can be manipulated to reduce the blanking time on the transducer to allow for object ranging as close as 6 inches.

In this implementation, the PIC16C74 asserts the BINH signal approximately 0.9 milliseconds after signal transmission. This enables the transducer to receive reflections off objects at a distance of 6 inches. The ranging module asserts the ECHO signal when a valid reflection has been detected. The PIC16C74 uses the ECHO signal to trigger a capture of the Timer1 value. The capture register contains the 16-bit value

representing the elapsed time between signal transmission and echo detection. The PIC16C74 then calculates object distance based on the Timer1 value, microcontroller clock speed, and the velocity of sound in the atmosphere. The basic equation for calculating distance is given below:

$$\text{Distance (inches)} = \text{TECHO time} / 147.9 \text{ microseconds}$$

**Note:** The minimum high and low time for INIT is 100 milliseconds, as seen in Figure 2.

## DESIGN CONSIDERATIONS

There are several design considerations which must be taken into account and are listed below.

The absolute measuring distance supported by the ranging module is 6 inches to 35 feet with an accuracy of +/- 1%.

The distance output from the ranging module can be averaged over time to filter distance calculations.

In some applications, the gain of the receiver amplifier may be too low or too high and may need to be adjusted. For example, if the transducer is mounted in a cylinder, the gain may need to be lowered to reduce false echoes within the cylinder. In this case, R1 (refer to the Polaroid Ultrasonic Ranging System manual) may be replaced with a 20 kΩ potentiometer to tweak the gain of the receiver amplifier to reduce false echoes.

In order for the Polaroid 6500 ranging module to operate properly, the power supply must be capable of handling high current transients (2.5 A) during the

transmit pulse. The instantaneous drain on the power supply can be mitigated by installing a storage capacitor across the power lines at the ranging module. A value of 500 microfarads is recommended.

A 200 millisecond interval is recommended between ranging cycles (Figure 2) to allow the transducer to clear.

The ECHO line requires a pull-up resistor (4.7 k $\Omega$  was used in this application).

There must be a common ground between the PIC16C74 circuitry and the ranging module.

Some applications may not need the resources of the higher end PIC16CXX devices. It is still possible to do this application using a device that does not contain a CCP module (for ECHO timing). The capture function can be implemented in firmware. The effect of a firmware implementation is that the resolution of the ECHO time would be 3 Tcy cycles versus 1 Tcy cycle for the CCP module. Also, the firmware implementation would not allow other tasks to be performed while the capture function was occurring.

Refer to Appendix A for general ranging module specifications.

## APPENDIX A: POLAROID MODULE SPECIFICATIONS

**Note:** This appendix contains general specifications from the Polaroid Ultrasonic Ranging System Manual. Please refer to the current Polaroid Ultrasonic Ranging System Manual for current information regarding ranging module design considerations.

### DESIGN CONSIDERATIONS IN ULTRASONICS

**Range:** (with user custom designed processing electronics)

#### Farther

- a) Use an acoustic horn to “focus” the sound (narrowing the beamwidth).
- b) Use two transducers – 1 receiver and 1 transmitter – facing each other.
- c) Lower the transmitting frequency (which will decrease the attenuation in air).

#### Closer

- a) Use a shorter transmit signal (such as four cycles).
- a) Use two transducers – one to transmit, one to receive (eliminates waiting for damping time).

#### Resolution

- a) Above all, know the target and range well, and design a system with them in mind.
- b) Use a higher transmit frequency.
- c) Look at phase differences of a given cycle of the transmitted signal and received echo (as opposed to using an integration technique).
- d) Increase the clock frequency of the timer.

**Accuracy:** (again, you must have a well defined target)

#### Temperature Compensate

- a) Use a second small target, as a reference, at a known distance in the ranging path (such as a 1/4” rod several feet away), process both echoes, then normalize the second distance with respect to the first, since  $t1/d1 = t2/d2$ .
- b) Incorporate a temperature sensing integrated circuit to drive a VCO to do the distance interval clocking.
- c) To increase sensitivity of detection circuit change the value of C4 from 3300 pF to 1000 pF on the 6500 Series Ranging Module.

#### Beam Width:

##### Increase

- a) Use an acoustic lens (to disperse the signal).
- b) Decrease the transmitting frequency.
- c) Use several transducers to span an area.

##### Decrease

- a) Use an acoustic horn (to focus the sound).
- b) Increase the transmitting frequency.

**TABLE 1: RECOMMENDED OPERATING CONDITIONS**

		Min.	Max.	Unit
Supply Voltage, Vcc		4.5	6.8	V
High-level input voltage, VIH	BINH, INIT	2.1		V
Low-level input voltage, VIL	BINH, INIT		0.6	V
ECHO and OSC output voltage			6.8	V
Delay time, power up to INIT high		5		ms
Recycle period		80		ms
Operating free-air temperature, TA		0	40	°C

**TABLE 2: ELECTRICAL CHARACTERISTICS OVER RECOMMENDED RANGES OF SUPPLY VOLTAGE AND OPERATING FREE-AIR TEMPERATURE (UNLESS OTHERWISE NOTED)**

Parameter		Test Conditions	Min.	Typ.	Max.	Unit
Input current	BINH, INIT	V1 = 2.1V			1	mA
High-level output current, I <sub>OH</sub>	ECHO, OSC	V <sub>OH</sub> = 5.5V			100	μA
Low-level output voltage, V <sub>OL</sub>	ECHO, OSC	I <sub>OL</sub> = 1.6 mA			0.4	V
Transducer bias voltage		T <sub>A</sub> = 25°C		200		V
Transducer output voltage (peak-to-peak)		T <sub>A</sub> = 25°C		400		V
Number of cycles for XDCR output to reach 400V		C = 500 pF			7	
Internal blanking interval				2.38*		ms
Frequency during 16-pulse transmit period	OSC output			49.4*		kHz
	XMIT output			49.4*		
Frequency after 16 pulse transmit period	OSC output			93.3*		kHz
	XMIT output			0		
Supply current, I <sub>CC</sub>	During transmit period				2000	mA
	After transmit period				100	

\* These typical values apply for a 420 kHz ceramic resonator.

# AN597

Please check the Microchip BBS for the latest version of the source code. For BBS access information, see Section 6, Microchip Bulletin Board Service information, page 6-3.

## APPENDIX B: FIRMWARE LISTING

```
MPASM 01.02 Released      XDCR.ASM  11-14-1994  9:29:15          PAGE  1
LOC OBJECT CODE          LINE SOURCE TEXT
VALUE

0001 ; XDCR.ASM
0002 ;
0003 ; This routine continually executes ranging cycles in the
0004 ; following order:
0005 ;
0006 ;     1) Timers and Flags are cleared
0007 ;     2) Ranging Cycle Executes
0008 ;     3) Distance is Calculated (to 0.5 inch)
0009 ;     4) HW is re-initialized for next cycle
0010 ;
0011 ; The processor uses a 4MHz oscillator, so all timing
0012 ; calculations are referenced to that. The calculated
0013 ; distance is a 16-bit result in the ACCbHI:ACCbLO registers.
0014 ;
0015
0016             LIST P=16C74, F=INHX8M
0017 ;
0029
0030 ;*****
0031 ; Bank 0 Registers
0032 ;*****
0033 ;
0034 ; TMR1 is off, Prescaler is 1 for a capture timeout of 65 msec
0000 0190 0035 clrf  T1CON
0036 ; Set to capture on every rising edge
0001 3005 0037 movlw  0x05
0002 0097 0038 movwf  CCP1CON
0039 ; Clear the Ports
0003 0185 0040 clrf  PORT_A
0004 0186 0041 clrf  PORT_B
0005 0187 0042 clrf  PORT_C
0006 0188 0043 clrf  PORT_D
0007 0189 0044 clrf  PORT_E
0045 ;
0046 ;*****
0047 ; Bank 1 Registers
0048 ;*****
0049 ;
0008 1683 0050 bsf   STATUS,RP0      ; Set RP0
0051 ; Port A is Digital, Port E is Digital
0009 3007 0052 movlw  0x07
000A 009F 0053 movwf  ADCON1
0054 ; Configure CCP1 (RC2) as an input, and all other ports
0055 ; as Outputs, (RE0 = INIT, RE1 = BINH)
000B 0185 0056 clrf  TRIS_A
000C 0186 0057 clrf  TRIS_B
000D 3004 0058 movlw  0x04
000E 0087 0059 movwf  TRIS_C
000F 0188 0060 clrf  TRIS_D
0010 0189 0061 clrf  TRIS_E
0011 1283 0062 bcf   STATUS,RP0      ; Clear RP0
0012
0063 Xdcr
0064 ;
0065 ; Initialize Timers and Flags
0066 ;
0012 1010 0067 bcf   T1CON,0          ; Disable TMR1
0013 018C 0068 clrf  PIR1          ; Clear Timer1 Overflow Flag & Timer1 Capture Flag
```

```

0014 018E 0069   clrf   TMR1L           ; Clear TMR1L
0015 018F 0070   clrf   TMR1H           ; Clear TMR1H
0016 0195 0071   clrf   CCPRL1L        ; Clear CCPRL1L
0017 0196 0072   clrf   CCPRL1H        ; Clear CCPRL1H
0018 1409 0073   bsf    PORT_E,0       ; Set INIT High on Ranging Module
0019 1410 0074   bsf    T1CON,0        ; Enable TMR1
001A 21F3 0075   call   DEL_9           ; Delay 0.9 msec for transducer to stabilize
001B 1489 0076   bsf    PORT_E,1       ; Enable Transducer to Receive (BINH)
001C      0077   chk_t1
001C 190C 0078   btfsc  PIR1,2         ; Check for Capture
001D 2822 0079   goto   chk_done       ; Jump if Capture
001E 1C0C 0080   btfss  PIR1,0         ; Check for TMR1 Overflow
001F 281C 0081   goto   chk_t1         ; Loop if nothing happened
0020 1010 0082   bcf    T1CON,0        ; Turn off TMR1
0021 2833 0083   goto   ovr_flo        ; Capture event did not occur
0022      0084   chk_done
0022      0085 ;
0022      0086 ; Calculate distance to 0.5 inch resolution
0022      0087 ;
0022 1010 0088   bcf    T1CON,0        ; Turn off TMR1
0023 0815 0089   movf   CCPRL1L,W      ; Move LSB into W
0024 00A2 0090   movwf  ACCbLO         ; Move LSB into ACCbLO
0025 0816 0091   movf   CCPRL1H,W      ; Move MSB into W
0026 00A3 0092   movwf  ACCbHI         ; Move MSB into ACCbHI
0027 304A 0093   movlw  0x4A           ; Move 75usec/0.50in into W
0028 00A0 0094   movwf  ACCaLO         ; Move LSB into ACCaLO
0029 01A1 0095   clrf   ACCaHI         ; Clear MSB (ACCaHI)
002A 208F 0096   call   D_divF         ; Call 16-bit/8-bit routine
002A      0097           ; which is described in
002A      0098           ; Application Note 544
002B 3025 0099   movlw  0x25           ; Check remainder to see if
002C 0224 0100   subwf  ACCcLO,W       ; we should round up...
002D 1803 0101   btfsc  STATUS,CARRY   ; If Remainder < (0.5 * Divisor), skip
002E 0AA2 0102   incf   ACCbLO,F       ; Round up
002F 1903 0103   btfsc  STATUS,Z       ; Check low byte for wrap around
0030 0AA3 0104   incf   ACCbHI,F       ; If LSB wrapped, increment high byte
0031 1D03 0105   btfss  STATUS,Z       ; Check high byte for wrap around
0032 2835 0106   goto   done           ; High byte didn't wrap
0033      0107   ovr_flo
0033 01A2 0108   clrf   ACCbLO         ; Clear ACCbLO
0034 01A3 0109   clrf   ACCbHI         ; Clear ACCbHI
0035      0110   done
0035 21FD 0111   call   DEL_100        ; Wait 100 msec before clearing HW.
0036 1009 0112   bcf    PORT_E,0       ; Disable INIT
0037 1089 0113   bcf    PORT_E,1       ; Disable BINH
0038 21FD 0114   call   DEL_100        ; Wait 100 msec before enabling HW.
0039 2812 0115   goto   Xdcr
0039      0116
0039      0120
0039      0149
0039      0150   end
0039      0151

```

MEMORY USAGE MAP ('X' = Used, '-' = Unused)

```

0000 : XXXXXXXXXXXXXXXXXXXX XXXXXXXXXXXXXXXXXXXX XXXXXXXXXXXXXXXXXXXX XXXXXXXXXXXX-----
0040 : -----

```

All other memory blocks unused.

```

Errors   :    0
Warnings :    0
Messages :    0

```

---

---

# WORLDWIDE SALES & SERVICE

---

---

## AMERICAS

### Corporate Office

Microchip Technology Inc.  
2355 West Chandler Blvd.  
Chandler, AZ 85224-6199  
Tel: 602 786-7200 Fax: 602 786-7277

### Atlanta

Microchip Technology Inc.  
500 Sugar Mill Road, Suite 200B  
Atlanta, GA 30350  
Tel: 404 640-0034 Fax: 404 640-0307

### Boston

Microchip Technology Inc.  
Five The Mountain Road, Suite 120  
Framingham, MA 01701  
Tel: 508 820-3334 Fax: 508 820-4326  
*After July 31, 1995:*  
Tel: 508 480-9990 Fax: 508 420-8575

### Chicago

Microchip Technology Inc.  
333 Pierce Road, Suite 180  
Itasca, IL 60143  
Tel: 708 285-0071 Fax: 708 285-0075

### Dallas

Microchip Technology Inc.  
14651 Dallas Parkway, Suite 816  
Dallas, TX 75240-8809  
Tel: 214 991-7177 Fax: 214 991-8588

### Dayton

Microchip Technology Inc.  
35 Rockridge Road  
Englewood, OH 45322  
Tel: 513 832-2543 Fax: 513 832-2841

### Los Angeles

Microchip Technology Inc.  
18201 Von Karman, Suite 455  
Irvine, CA 92715  
Tel: 714 263-1888 Fax: 714 263-1338

### New York

Microchip Technology Inc.  
150 Motor Parkway, Suite 416  
Hauppauge, NY 11788  
Tel: 516 273-5305 Fax: 516 273-5335

## AMERICAS (continued)

### San Jose

Microchip Technology Inc.  
2107 North First Street, Suite 590  
San Jose, CA 95131  
Tel: 408 436-7950 Fax: 408 436-7955

## ASIA/PACIFIC

### Hong Kong

Microchip Technology Inc.  
Unit No. 3002-3004, Tower 1  
Metroplaza  
223 Hing Fong Road  
Kwai Fong, N.T. Hong Kong  
Tel: 852 2 401 1200 Fax: 852 2 401 3431

### Korea

Microchip Technology Korea  
168-1, Youngbo Bldg. 3 Floor  
Samsung-Dong, Kangnam-Ku,  
Seoul, Korea  
Tel: 82 2 554 7200 Fax: 82 2 558 5934

### Singapore

Microchip Technology Inc.  
200 Middle Road  
#10-03 Prime Centre  
Singapore 0718  
Tel: 65 334 8870 Fax: 65 334 8850

### Taiwan

Microchip Technology Taiwan  
10F-1C 207  
Tung Hua North Road  
Taipei, Taiwan, ROC  
Tel: 886 2 717 7175 Fax: 886 2 545 0139

## EUROPE

### United Kingdom

Arizona Microchip Technology Ltd.  
Unit 6, The Courtyard  
Meadow Bank, Furlong Road  
Bourne End, Buckinghamshire  
SL8 5AJ  
Tel: 44 0 1628 851077 Fax: 44 0 1628 850259

### France

Arizona Microchip Technology SARL  
2 Rue du Buisson aux Fraises  
91300 Massy - France  
Tel: 33 1 69 53 63 20 Fax: 33 1 69 30 90 79

### Germany

Arizona Microchip Technology GmbH  
Gustav-Heinemann-Ring 125  
D-81739 Muenchen, Germany  
Tel: 49 89 627 144 0 Fax: 49 89 627 144 44

### Italy

Arizona Microchip Technology SRL  
Centro Direzionale Colleoni  
Palazzo Pegaso Ingresso No. 2  
Via Paracelso 23, 20041  
Agrate Brianza (MI) Italy  
Tel: 39 039 689 9939 Fax: 39 039 689 9883

## JAPAN

Microchip Technology Intl. Inc.  
Benex S-1 6F  
3-18-20, Shin Yokohama  
Kohoku-Ku, Yokohama  
Kanagawa 222 Japan  
Tel: 81 45 471 6166 Fax: 81 45 471 6122



**MICROCHIP**

Printed in the USA, 6/6/95  
© 1995, Microchip Technology Inc.

\*Information contained in this publication regarding device applications and the like is intended by way of suggestion only. No representation of warranty is given and no liability is assumed by Microchip Technology Inc. with respect to the accuracy or use of such information. Use of Microchip's products as critical components in life support systems is not authorized except with express written approval by Microchip. The Microchip logo and name are trademarks of Microchip Technology Incorporated. All rights reserved. All other trademarks mentioned herein are the property of their respective companies.