

**FEATURES**

Easy to Use

Low Cost Solution

Higher Performance than Two or Three Op Amp Design

Unity Gain with No External Resistor

Optional Gains with One External Resistor

(Gain Range 2 to 1000)

Wide Power Supply Range ( $\pm 2.6$  V to  $\pm 15$  V)

Available in 8-Lead PDIP and SOIC

Low Power, 1.5 mA max Supply Current

**GOOD DC PERFORMANCE**0.15% Gain Accuracy ( $G = 1$ )250  $\mu$ V max Input Offset Voltage2.0  $\mu$ V/ $^{\circ}$ C max Input Offset Drift

5 nA max Input Bias Current

66 dB min Common-Mode Rejection Ratio ( $G = 1$ )**NOISE**12 nV/ $\sqrt{\text{Hz}}$  @ 1 kHz Input Voltage Noise0.60  $\mu$ V p-p Noise (0.1 Hz to 10 Hz,  $G = 10$ )**EXCELLENT AC CHARACTERISTICS**800 kHz Bandwidth ( $G = 10$ )10  $\mu$ s Settling Time to 0.1% @  $G = 1-100$ 1.2 V/ $\mu$ s Slew Rate**APPLICATIONS**

Transducer Interface

Low Cost Thermocouple Amplifier

Industrial Process Controls

Difference Amplifier

Low Cost Data Acquisition

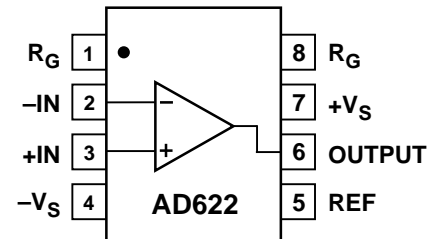
**CONNECTION DIAGRAM****PRODUCT DESCRIPTION**

The AD622 is a low cost, moderately accurate instrumentation amplifier that requires only one external resistor to set any gain between 2 and 1,000. Or for a gain of 1, no external resistor is required. The AD622 is a complete difference or subtracter amplifier "system" while providing superior linearity and common-mode rejection by incorporating precision laser trimmed resistors.

The AD622 replaces low cost, discrete, two or three op amp instrumentation amplifier designs and offers good common-mode rejection, superior linearity, temperature stability, reliability, and board area consumption. The low cost of the AD622 eliminates the need to design discrete instrumentation amplifiers to meet stringent cost targets. While providing a lower cost solution, it also provides performance and space improvements.

REV. 0

Information furnished by Analog Devices is believed to be accurate and reliable. However, no responsibility is assumed by Analog Devices for its use, nor for any infringements of patents or other rights of third parties which may result from its use. No license is granted by implication or otherwise under any patent or patent rights of Analog Devices.

© Analog Devices, Inc., 1996

One Technology Way, P.O. Box 9106, Norwood, MA 02062-9106, U.S.A.  
Tel: 617/329-4700 Fax: 617/326-8703

# AD622—SPECIFICATIONS (typical @ +25°C, $V_S = \pm 15$ V, and $R_L = 2$ k $\Omega$ unless otherwise noted)

| Model  | Conditions  | AD622        |          |              | Units           |
|--|---|--------------|----------|--------------|-----------------|
|  |   | Min          | Typ      | Max          |                 |
| <b>GAIN</b>  | $G = 1 + (50.5 \text{ k}/R_G)$                            |              |          |              |                 |
| Gain Range   |   | 1            |          | 1000         |                 |
| Gain Error <sup>1</sup>  | $V_{OUT} = \pm 10$ V                                      |              |          |              |                 |
| G = 1  |   |              | 0.05     | 0.15         | %               |
| G = 10   |   |              | 0.2      | 0.50         | %               |
| G = 100  |   |              | 0.2      | 0.50         | %               |
| G = 1000   |   |              | 0.2      | 0.50         | %               |
| Nonlinearity,  | $V_{OUT} = \pm 10$ V                                      |              |          |              |                 |
| G = 1–1000   | $R_L = 10$ k $\Omega$                                     |              | 10       |              | ppm             |
| G = 1–100  | $R_L = 2$ k $\Omega$                                      |              | 10       |              | ppm             |
| Gain vs. Temperature   | Gain <1000 <sup>1</sup>                                   |              |          | -50          | ppm/°C          |
| <b>VOLTAGE OFFSET</b>  | (Total RTI Error = $V_{OS1} + V_{OSO}/G$ )                |              |          |              |                 |
| Input Offset, $V_{OS1}$  | $V_S = \pm 5$ V to $\pm 15$ V                             |              | 60       | 250          | $\mu$ V         |
| Average TC   | $V_S = \pm 5$ V to $\pm 15$ V                             |              |          | 2.0          | $\mu$ V/°C      |
| Output Offset, $V_{OSO}$   | $V_S = \pm 5$ V to $\pm 15$ V                             |              | 600      | 1500         | $\mu$ V         |
| Average TC   | $V_S = \pm 5$ V to $\pm 15$ V                             |              |          | 15           | $\mu$ V/°C      |
| Offset Referred to the<br>Input vs.<br>Supply (PSR)                              | $V_S = \pm 5$ V to $\pm 15$ V                             |              |          |              |                 |
| G = 1  |   | 80           | 100      |              | dB              |
| G = 10   |   | 95           | 120      |              | dB              |
| G = 100  |   | 110          | 140      |              | dB              |
| G = 1000   |   | 110          | 140      |              | dB              |
| <b>INPUT CURRENT</b>   |   |              |          |              |                 |
| Input Bias Current   |   |              | 2.0      | 5.0          | nA              |
| Average TC   |   |              | 3.0      |              | pA/°C           |
| Input Offset Current   |   |              | 0.7      | 2.5          | nA              |
| Average TC   |   |              | 2.0      |              | pA/°C           |
| <b>INPUT</b>   |   |              |          |              |                 |
| Input Impedance  |   |              |          |              |                 |
| Differential   |   |              | 10  2    |              | G $\Omega$   pF |
| Common-Mode  |   |              | 10  2    |              | G $\Omega$   pF |
| Input Voltage Range <sup>2</sup>   | $V_S = \pm 2.6$ V to $\pm 5$ V                            | $-V_S + 1.9$ |          | $+V_S - 1.2$ | V               |
| Over Temperature   |   | $-V_S + 2.1$ |          | $+V_S - 1.3$ | V               |
|  | $V_S = \pm 5$ V to $\pm 18$ V                             | $-V_S + 1.9$ |          | $+V_S - 1.4$ | V               |
| Over Temperature   |   | $-V_S + 2.1$ |          | $+V_S - 1.4$ | V               |
| Common-Mode Rejection<br>Ratio DC to 60 Hz with<br>1 k $\Omega$ Source Imbalance | $V_{CM} = 0$ V to $\pm 10$ V                              |              |          |              |                 |
| G = 1  |   | 66           | 78       |              | dB              |
| G = 10   |   | 86           | 98       |              | dB              |
| G = 100  |   | 103          | 118      |              | dB              |
| G = 1000   |   | 103          | 118      |              | dB              |
| <b>OUTPUT</b>  |   |              |          |              |                 |
| Output Swing   | $R_L = 10$ k $\Omega$ ,<br>$V_S = \pm 2.6$ V to $\pm 5$ V | $-V_S + 1.1$ |          | $+V_S - 1.2$ | V               |
| Over Temperature   |   | $-V_S + 1.4$ |          | $+V_S - 1.3$ | V               |
|  | $V_S = \pm 5$ V to $\pm 18$ V                             | $-V_S + 1.2$ |          | $+V_S - 1.4$ | V               |
| Over Temperature   |   | $-V_S + 1.6$ |          | $+V_S - 1.5$ | V               |
| Short Current Circuit  |   |              | $\pm 18$ |              | mA              |

| Model                              | Conditions   | AD622     |               |                | Units         |      |
|------------------------------------|--|-----------|---------------|----------------|---------------|------|
|                                    |  | Min       | Typ           | Max            |               |      |
| <b>DYNAMIC RESPONSE</b>            |  |           |               |                |               |      |
| Small Signal -3 dB Bandwidth       | 10 V Step  |           | 1000          |                | kHz           |      |
| G = 1                              |  |           | 800           |                | kHz           |      |
| G = 10                             |  |           | 120           |                | kHz           |      |
| G = 1000                           |  |           | 12            |                | kHz           |      |
| Slew Rate                          |  |           |               | 1.2            |               | V/μs |
| Settling Time to 0.1%<br>G = 1-100 |  |           | 10            |                | μs            |      |
| <b>NOISE</b>                       |  |           |               |                |               |      |
| Voltage Noise, 1 kHz               | $Total\ RTI\ Noise = \sqrt{(e_{ni}^2) + (e_{no}/G)^2}$ |           | 12            |                | nV/√Hz        |      |
| Input, Voltage Noise, $e_{ni}$     |  |           | 72            |                | nV/√Hz        |      |
| Output, Voltage Noise, $e_{no}$    |  |           |               |                |               |      |
| RTI, 0.1 Hz to 10 Hz               | f = 1 kHz  |           | 4.0           |                | μV p-p        |      |
| G = 1                              |  |           | 0.6           |                | μV p-p        |      |
| G = 10                             |  |           | 0.3           |                | μV p-p        |      |
| G = 100-1000                       |  |           | 100           |                | fA/√Hz        |      |
| Current Noise                      |  |           | 10            |                | pA p-p        |      |
| 0.1 Hz to 10 Hz                    |  |           |               |                |               |      |
| <b>REFERENCE INPUT</b>             |  |           |               |                |               |      |
| $R_{IN}$                           | $V_{IN+}, V_{REF} = 0$                                 |           | 20            |                | kΩ            |      |
| $I_{IN}$                           |  |           | +50           | +60            | μA            |      |
| Voltage Range                      |  |           | - $V_S + 1.6$ |                | + $V_S - 1.6$ | V    |
| Gain to Output                     |  |           |               | $1 \pm 0.0015$ |               |      |
| <b>POWER SUPPLY</b>                |  |           |               |                |               |      |
| Operating Range <sup>3</sup>       | $V_S = \pm 2.6\ V\ to\ \pm 18\ V$                      | $\pm 2.6$ |               | $\pm 18$       | V             |      |
| Quiescent Current                  |  |           | 0.9           | 1.3            | mA            |      |
| Over Temperature                   |  |           | 1.1           | 1.5            | mA            |      |
| <b>TEMPERATURE RANGE</b>           |  |           |               |                |               |      |
| For Specified Performance          |  |           | -40 to +85    |                | °C            |      |

## NOTES

<sup>1</sup>Does not include effects of external resistor  $R_G$ .<sup>2</sup>One input grounded.  $G = 1$ .<sup>3</sup>This is defined as the same supply range that is used to specify PSR.

Specifications subject to change without notice.

# AD622

## ABSOLUTE MAXIMUM RATINGS<sup>1</sup>

|   |                 |
|---|-----------------|
| Supply Voltage                          | ±18 V           |
| Internal Power Dissipation <sup>2</sup> | 650 mW          |
| Input Voltage (Common Mode)             | ±V <sub>S</sub> |
| Differential Input Voltage              | ±25 V           |
| Output Short Circuit Duration           | Indefinite      |
| Storage Temperature Range (N, R)        | -65°C to +125°C |
| Operating Temperature Range             |                 |
| AD622A                                  | -40°C to +85°C  |
| Lead Temperature Range                  |                 |
| (Soldering 10 seconds)                  | +300°C          |

## NOTES

<sup>1</sup>Stresses above those listed under “Absolute Maximum Ratings” may cause permanent damage to the device. This is a stress rating only and functional operation of the device at these or any other conditions above those indicated in the operational section of this specification is not implied. Exposure to absolute maximum rating conditions for extended periods may affect device reliability.

<sup>2</sup>Specification is for device in free air:

8-Pin Plastic Package:  $\theta_{JA} = 95^\circ\text{C/Watt}$

8-Pin SOIC Package:  $\theta_{JA} = 155^\circ\text{C/Watt}$

## ORDERING GUIDE

| Model*  | Temperature Range | Package Option |
|---------|-------------------|----------------|
| AD622AN | -40°C to +85°C    | N-8            |
| AD622AR | -40°C to +85°C    | SO-8           |

\*N = Plastic DIP, R = SOIC.

## CAUTION

ESD (electrostatic discharge) sensitive device. Electrostatic charges as high as 4000 V readily accumulate on the human body and test equipment and can discharge without detection. Although the AD622 features proprietary ESD protection circuitry, permanent damage may occur on devices subjected to high energy electrostatic discharges. Therefore, proper ESD precautions are recommended to avoid performance degradation or loss of functionality.



## Typical Characteristics (@ +25°C, V<sub>S</sub> = ±15 V, R<sub>L</sub> = 2 kΩ, unless otherwise noted)

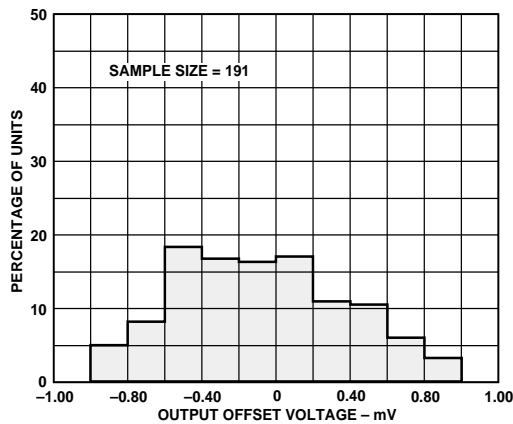

Figure 1. Typical Distribution of Output Offset Voltage

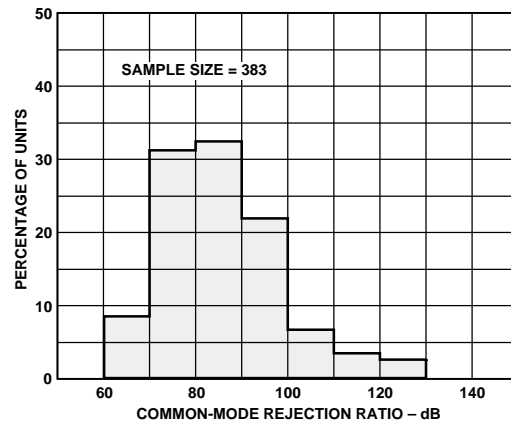

Figure 2. Typical Distribution of Common-Mode Rejection

Typical Characteristics (@ +25°C,  $V_S = \pm 15\text{ V}$ ,  $R_L = 2\text{ k}\Omega$ , unless otherwise noted)

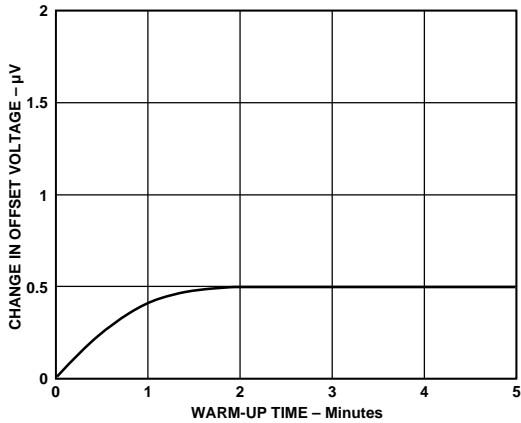

Figure 3. Change in Input Offset Voltage vs. Warm-Up Time

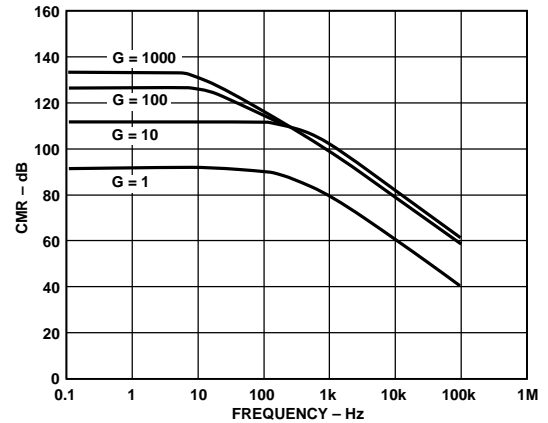

Figure 6. CMR vs. Frequency, RTI, Zero to 1 kΩ Source Imbalance

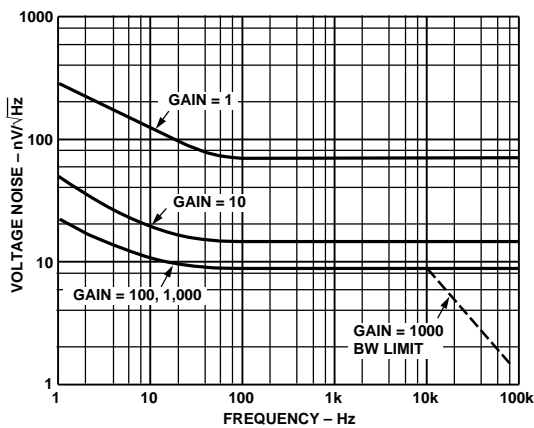

Figure 4. Voltage Noise Spectral Density vs. Frequency, (G = 1-1000)

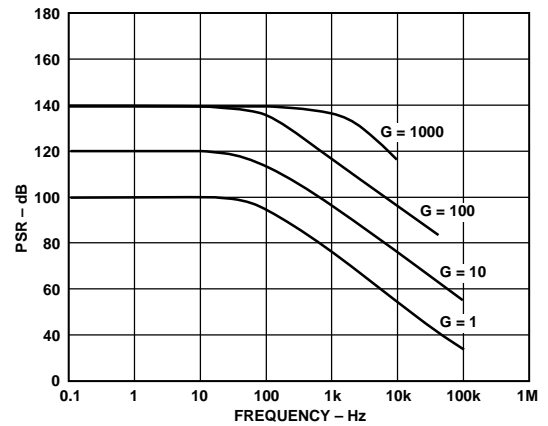

Figure 7a. Positive PSR vs. Frequency, RTI (G = 1-1000)

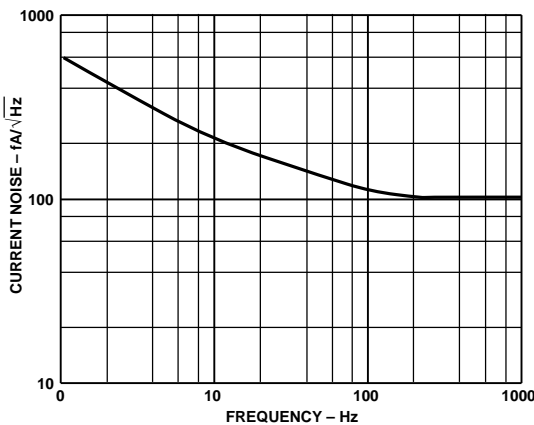

Figure 5. Current Noise Spectral Density vs. Frequency

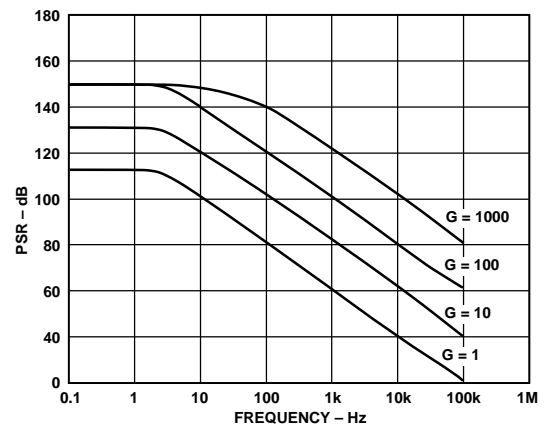

Figure 7b. Negative PSR vs. Frequency, RTI (G = 1-1000)

# AD622—Typical Characteristics (@ +25°C, $V_S = \pm 15\text{ V}$ , $R_L = 2\text{ k}\Omega$ , unless otherwise noted)

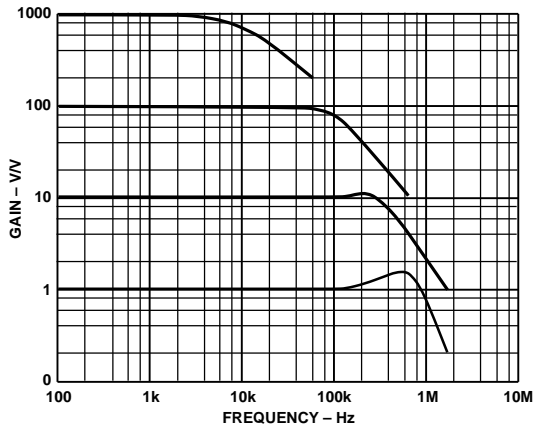

Figure 8. Gain vs. Frequency

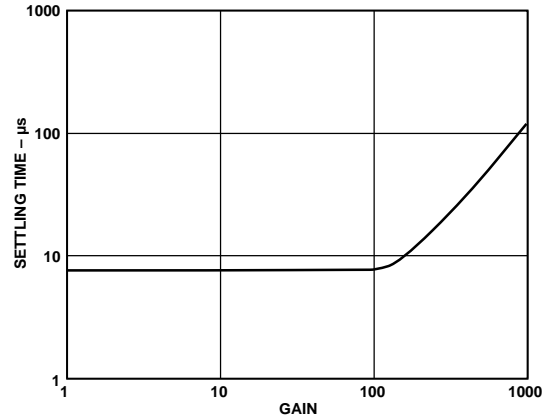

Figure 11. Settling Time to 0.1% vs. Gain, for a 10 V Step

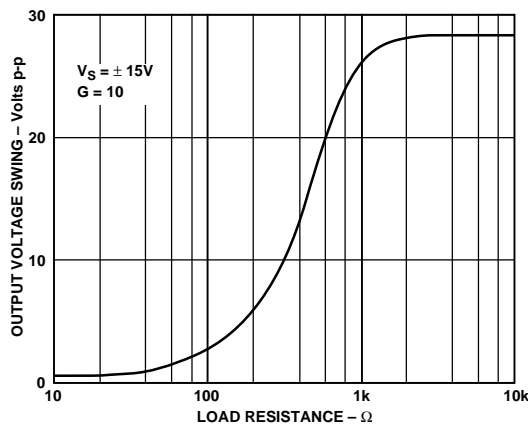

Figure 9. Output Voltage Swing vs. Load Resistance

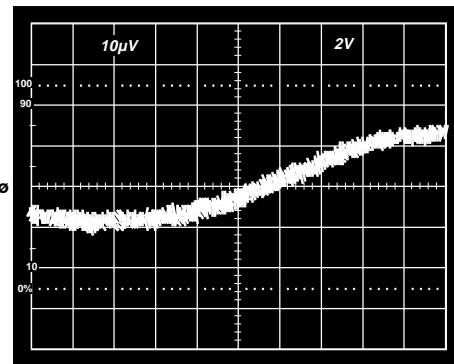

Figure 12. Gain Nonlinearity,  $G = 1$ ,  $R_L = 10\text{ k}\Omega$  ( $20\text{ }\mu\text{V} = 2\text{ ppm}$ )

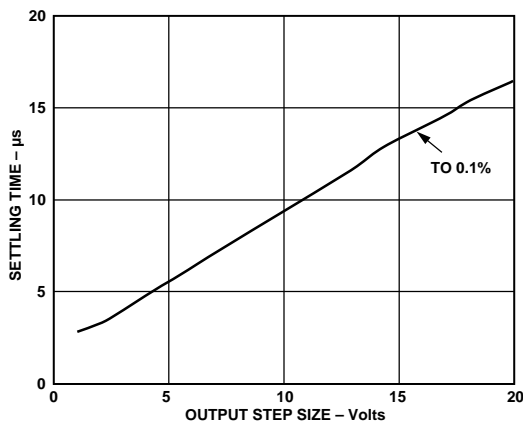

Figure 10. Settling Time vs. Step Size ( $G = 1$ )

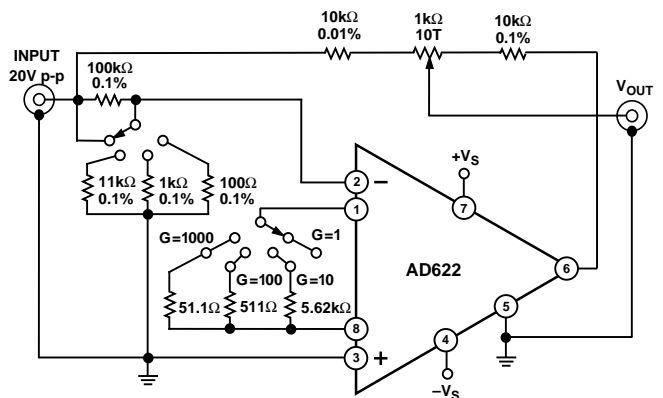

Figure 13. Settling Time Test Circuit

## THEORY OF OPERATION

The AD622 is a monolithic instrumentation amplifier based on a modification of the classic three op-amp approach. Absolute value trimming allows the user to program gain *accurately* (to 0.5% at  $G = 100$ ) with only one resistor. Monolithic construction and laser wafer trimming allow the tight matching and tracking of circuit components, thus insuring its performance.

The input transistors Q1 and Q2 provide a single differential-pair bipolar input for high precision. Feedback through the Q1-A1-R1 loop and the Q2-A2-R2 loop maintains constant collector current of the input devices Q1, Q2 thereby impressing the input voltage across the external gain-setting resistor  $R_G$ . This creates a differential gain from the inputs to the A1/A2 outputs given by  $G = (R_1 + R_2)/R_G + 1$ . The unity-gain subtracter A3 removes any common-mode signal, yielding a single-ended output referred to the REF pin potential.

The value of  $R_G$  also determines the transconductance of the preamp stage. As  $R_G$  is reduced for larger gains, the transconductance increases asymptotically to that of the input transistors. This has three important advantages: (a) Open-loop gain is boosted for increasing programmed gain, thus reducing gain-related errors. (b) The gain-bandwidth product (determined by C1, C2 and the preamp transconductance) increases with programmed gain, thus optimizing frequency response. (c) The input voltage noise is reduced to a value of  $12 \text{ nV}/\sqrt{\text{Hz}}$ , determined mainly by the collector current and base resistance of the input devices.

The internal gain resistors, R1 and R2, are trimmed to an absolute value of  $25.25 \text{ k}\Omega$ , allowing the gain to be programmed accurately with a single external resistor.

## Make vs. Buy: A Typical Application Error Budget

The AD622 offers a cost and performance advantages over discrete “two op-amp” instrumentation amplifier designs along with smaller size and less components. In a typical application shown in Figure 14, a gain of 10 is required to receive and amplify a 0–20 mA signal from the AD694 current transmitter. The current is converted to a voltage in a  $50 \Omega$  shunt. In applications where transmission is over long distances, line impedance can be significant so that differential voltage measurement is essential. Where there is no connection between the ground returns of transmitter and receiver, there must be a dc path from each input to ground, implemented in this case using two  $1 \text{ k}\Omega$  resistors. The error budget detailed in Table I shows how to calculate the effect various error sources have on circuit accuracy.

The AD622 provides greater accuracy at lower cost. The higher cost of the “homebrew” circuit is dominated in this case by the matched resistor network. One could also realize a “homebrew” design using cheaper discrete resistors which would be either trimmed or hand selected to give high common-mode rejection. This level of common-mode rejection would however degrade significantly over temperature due to the drift mismatch of the discrete resistors.

Note that for the homebrew circuit, the LT1013 specification for noise has been multiplied by  $\sqrt{2}$ . This is because a “two op-amp” type instrumentation amplifier has two op amps at its inputs, both contributing to the overall noise.

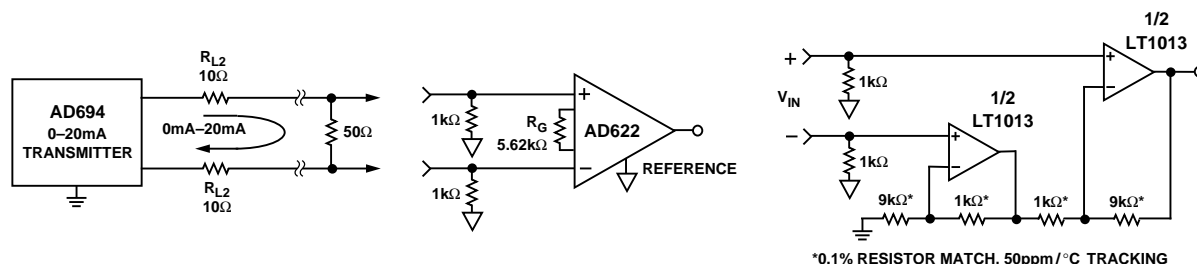

0–20 mA Current Loop  
with  $50 \Omega$  Shunt Impedance

AD622 Monolithic  
Instrumentation Amplifier,  
 $G = 9.986$

“Homebrew” In Amp,  $G = 10$

Figure 14. Make vs. Buy

Table I. Make vs. Buy Error Budget

| Error Source   | AD622 Circuit Calculation   | “Homebrew” Circuit Calculation   | Total Error in ppm Relative to 1 V FS AD622 | Total Error in ppm Relative to 1 V FS Homebrew |
|--|---|--|---|--|
| <b>ABSOLUTE ACCURACY</b> at $T_A = +25^\circ\text{C}$  |   |  |   |  |
| Total RTI Offset Voltage, $\mu\text{V}$                | $250 \mu\text{V} + 1500 \mu\text{V}/10$   | $800 \mu\text{V} \times 2$   | 400   | 1600   |
| Input Offset Current, nA                               | $2.5 \text{ nA} \times 1 \text{ k}\Omega$   | $15 \text{ nA} \times 1 \text{ k}\Omega$   | 2.5   | 15   |
| CMR, dB  | $86 \text{ dB} \rightarrow 50 \text{ ppm} \times 0.5 \text{ V}$                             | $(0.1\% \text{ Match} \times 0.5 \text{ V})/10 \text{ V}$                        | 25  | 50   |
| <b>DRIFT TO <math>+85^\circ\text{C}</math></b>         |   |  |   |  |
| Gain Drift, ppm/ $^\circ\text{C}$                      | $(50 \text{ ppm} + 5 \text{ ppm}) \times 60^\circ\text{C}$                                  | $(50 \text{ ppm})/^\circ\text{C} \times 60^\circ\text{C}$                        | 3300  | 3000   |
| Total RTI Offset Voltage, $\mu\text{V}/^\circ\text{C}$ | $(2 \mu\text{V}/^\circ\text{C} + 15 \mu\text{V}/^\circ\text{C}/10) \times 60^\circ\text{C}$ | $9 \mu\text{V}/^\circ\text{C} \times 2 \times 60^\circ\text{C}$                  | 210   | 1080   |
| Input Offset Current, pA/ $^\circ\text{C}$             | $2 \text{ pA}/^\circ\text{C} \times 1 \text{ k}\Omega \times 60^\circ\text{C}$              | $155 \text{ pA}/^\circ\text{C} \times 1 \text{ k}\Omega \times 60^\circ\text{C}$ | 0.12  | 9.3  |
| <b>RESOLUTION</b>                                      |   |  |   |  |
| Gain Nonlinearity, ppm of Full Scale                   | 10 ppm  | 20 ppm   | 10  | 20   |
| Typ 0.1 Hz–10 Hz Voltage Noise, $\mu\text{V p-p}$      | 0.6 $\mu\text{V p-p}$   | $0.55 \mu\text{V p-p} \times \sqrt{2}$   | 0.6   | 0.778  |
|  |   | Total Drift Error  | 3510.12                                     | 4089.3   |
|  |   | Total Resolution Error   | 10.6  | 20.778   |
|  |   | Grand Total Error  | 3948  | 5575   |

**GAIN SELECTION**

The AD622’s gain is resistor programmed by  $R_G$ , or more precisely, by whatever impedance appears between Pins 1 and 8. The AD622 is designed to offer gains as close as possible to popular integer values using standard 1% resistors. Table II shows required values of  $R_G$  for various gains. Note that for  $G = 1$ , the  $R_G$  pins are unconnected ( $R_G = \infty$ ). For any arbitrary gain  $R_G$  can be calculated by using the formula

$$R_G = \frac{50.5 \text{ k}\Omega}{G - 1}$$

To minimize gain error avoid high parasitic resistance in series with  $R_G$ , and to minimize gain drift,  $R_G$  should have a low TC—less than 10 ppm/ $^\circ\text{C}$  for the best performance.

Table II. Required Values of Gain Resistors

| Desired Gain | 1% Std Table Value of $R_G$ , $\Omega$ | Calculated Gain |
|--------------|--|-----------------|
| 2            | 51.1 k                                 | 1.988           |
| 5            | 12.7 k                                 | 4.976           |
| 10           | 5.62 k                                 | 9.986           |
| 20           | 2.67 k                                 | 19.91           |
| 33           | 1.58 k                                 | 32.96           |
| 40           | 1.3 k                                  | 39.85           |
| 50           | 1.02 k                                 | 50.50           |
| 65           | 787                                    | 65.17           |
| 100          | 511                                    | 99.83           |
| 200          | 255                                    | 199.0           |
| 500          | 102                                    | 496.1           |
| 1000         | 51.1                                   | 989.3           |



### INPUT AND OUTPUT OFFSET VOLTAGE

The low errors of the AD622 are attributed to two sources, input and output errors. The output error is divided by  $G$  when referred to the input. In practice, the input errors dominate at high gains and the output errors dominate at low gains. The total  $V_{OS}$  for a given gain is calculated as:

$$\text{Total Error RTI} = \text{input error} + (\text{output error}/G)$$

$$\text{Total Error RTO} = (\text{input error} \times G) + \text{output error}$$

### REFERENCE TERMINAL

The reference terminal potential defines the zero output voltage and is especially useful when the load does not share a precise ground with the rest of the system. It provides a direct means of injecting a precise offset to the output, with an allowable range of 2 V within the supply voltages. Parasitic resistance should be kept to a minimum for optimum CMR.

### INPUT PROTECTION

The AD622 features 400  $\Omega$  of series thin film resistance at its inputs, and will safely withstand input overloads of up to  $\pm 25$  V or  $\pm 60$  mA for up to an hour. This is true for all gains and power on and off, which is particularly important since the signal source and amplifier may be powered separately. For continuous input overload, the current should not exceed 6 mA ( $I_{IN} \leq V_{IN}/400 \Omega$ ). For input overloads beyond the supplies, clamping the inputs to the supplies (using a diode such as an IN4148) will reduce the required resistance, yielding lower noise.

### RF INTERFERENCE

All instrumentation amplifiers can rectify high frequency out of band signals. Once rectified, these signals appear as dc offset errors at the output. As shown in Figure 15, a low-pass filter can be used to prevent unwanted noise from reaching the differential inputs. A capacitor is connected across the inputs of the instrumentation amplifier and forms a differential low-pass filter with the two resistors. An additional benefit of using a differentially connected capacitor is that it reduces common-mode capacitance imbalance which helps to preserve high frequency common-mode rejection. In applications where the sensor is an RTD or a resistive strain gage, the filter resistors can be omitted if the sensor is physically close to the amplifier inputs. It is important to note that resistor tolerance or mismatch, poor layout and excessive resistor thermal noise (caused by large resistor values) can all contribute to degrading the effectiveness of this filter.

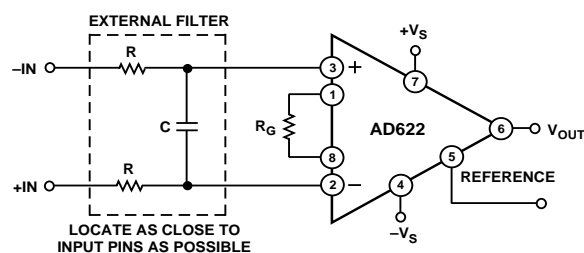

Figure 15. Circuit to Attenuate RF Interference

In many applications shielded cables are used to minimize noise, and for best CMR over frequency the shield should be properly driven. Figure 16 shows an active guard drive which is configured to improve ac common-mode rejection by “bootstrapping” the capacitances of input cable shields, thus minimizing the capacitance mismatch between the inputs.

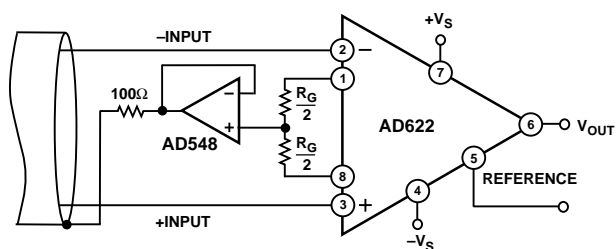

Figure 16. Common-Mode Shield Driver

# AD622

## GROUNDING

Since the AD622 output voltage is developed with respect to the potential on the reference terminal, it can solve many grounding problems by simply tying the REF pin to the appropriate “local ground.” The REF pin should however be tied to a low impedance point for optimal CMR.

The use of ground planes is recommended to minimize the impedance of ground returns (and hence the size of dc errors). In order to isolate low level analog signals from a noisy digital environment, many data-acquisition components have separate analog and digital ground returns (Figure 15). All ground pins from mixed signal components such as analog to digital converters should be returned through the “high quality” analog ground plane. Maximum isolation between analog and digital is achieved by connecting the ground planes back at the supplies. The digital return currents from the ADC which flow in the analog ground plane will in general have a negligible effect on noise performance.

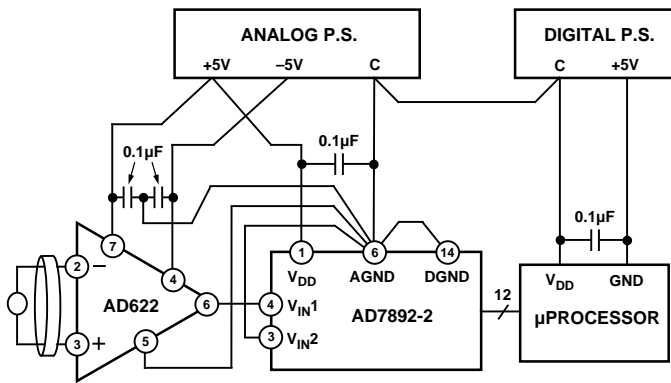

Figure 17. Basic Grounding Practice

## GROUND RETURNS FOR INPUT BIAS CURRENTS

Input bias currents are those currents necessary to bias the input transistors of an amplifier. There must be a direct return path for these currents; therefore when amplifying “floating” input sources such as transformers, or ac-coupled sources, there must be a dc path from each input to ground as shown in Figure 18. Refer to the *Instrumentation Amplifier Application Guide* (free from Analog Devices) for more information regarding in amp applications.

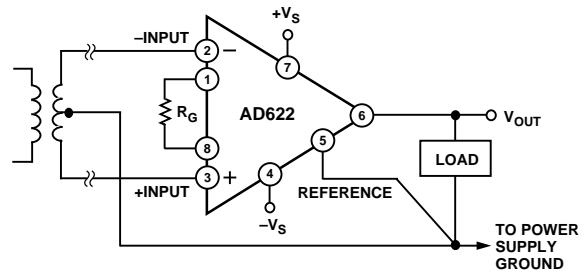

Figure 18a. Ground Returns for Bias Currents with Transformer Coupled Inputs

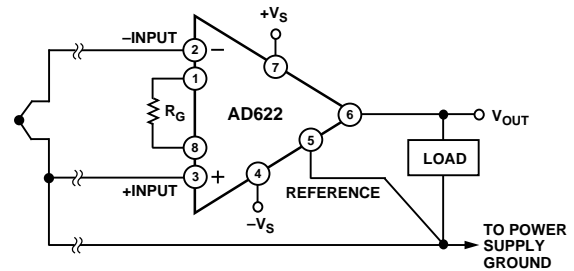

Figure 18b. Ground Returns for Bias Currents with Thermocouple Inputs

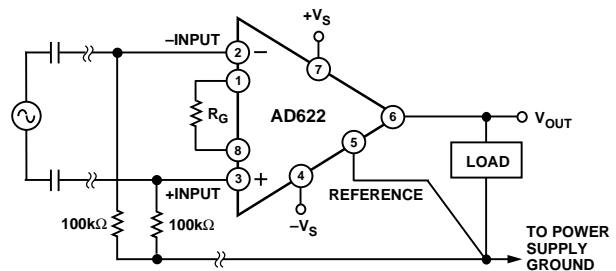
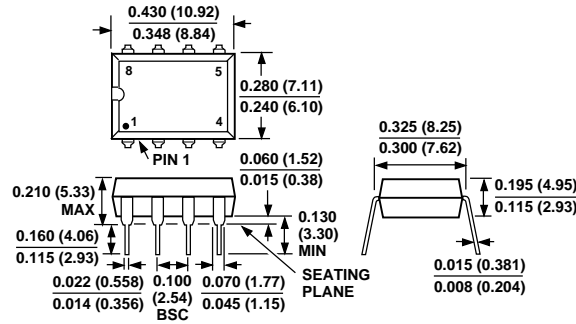

Figure 18c. Ground Returns for Bias Currents with AC Coupled Inputs

**OUTLINE DIMENSIONS**

Dimensions shown in inches and (mm).

**Plastic DIP (N-8) Package**



**SOIC (SO-8) Package**

