

ASSP

DUAL COMPARATOR

MB47393

■ DESCRIPTION

The Fujitsu MB47393 is a dual comparator which is designed to operate from a single power supply over a wide range of voltage. The input characteristics is equivalent of current industry standard comparator. Even though operated from a single power supply, the input common mode voltage range includes ground. Owing to adoption of clamp circuitry in input pins, mis-operation is prevented by negative input. The MB47393 is compatible with LM393.

■ FEATURES

- Wide power supply voltage range
Single power supply — 2V to 30V
Dual power supplies — $\pm 1V$ to $\pm 15V$
- Wide input common-mode voltage range
0V to $(V_{CC} - 1.5)V$
- Low input bias current — 25nA typ.
- High sink current capability because of open collector output 40mA min.
- Package
Plastic 8 pin DIP package (Suffix: -P)
Plastic 8 pin FPT package (Suffix: -PF)
Plastic 9 pin SIP package (Suffix: -PS)

■ PACKAGE

PLAPMSTIC PACKAGE
DIP-08P-M01

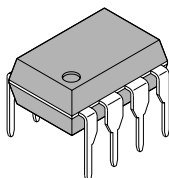

PLAPMSTIC PACKAGE
FPT-08P-M01

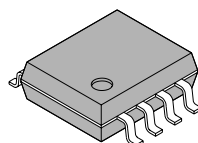

PLAPMSTIC PACKAGE
SIP-09P-M01

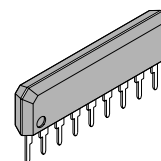

MB47393

■ PIN ASSIGNMENT

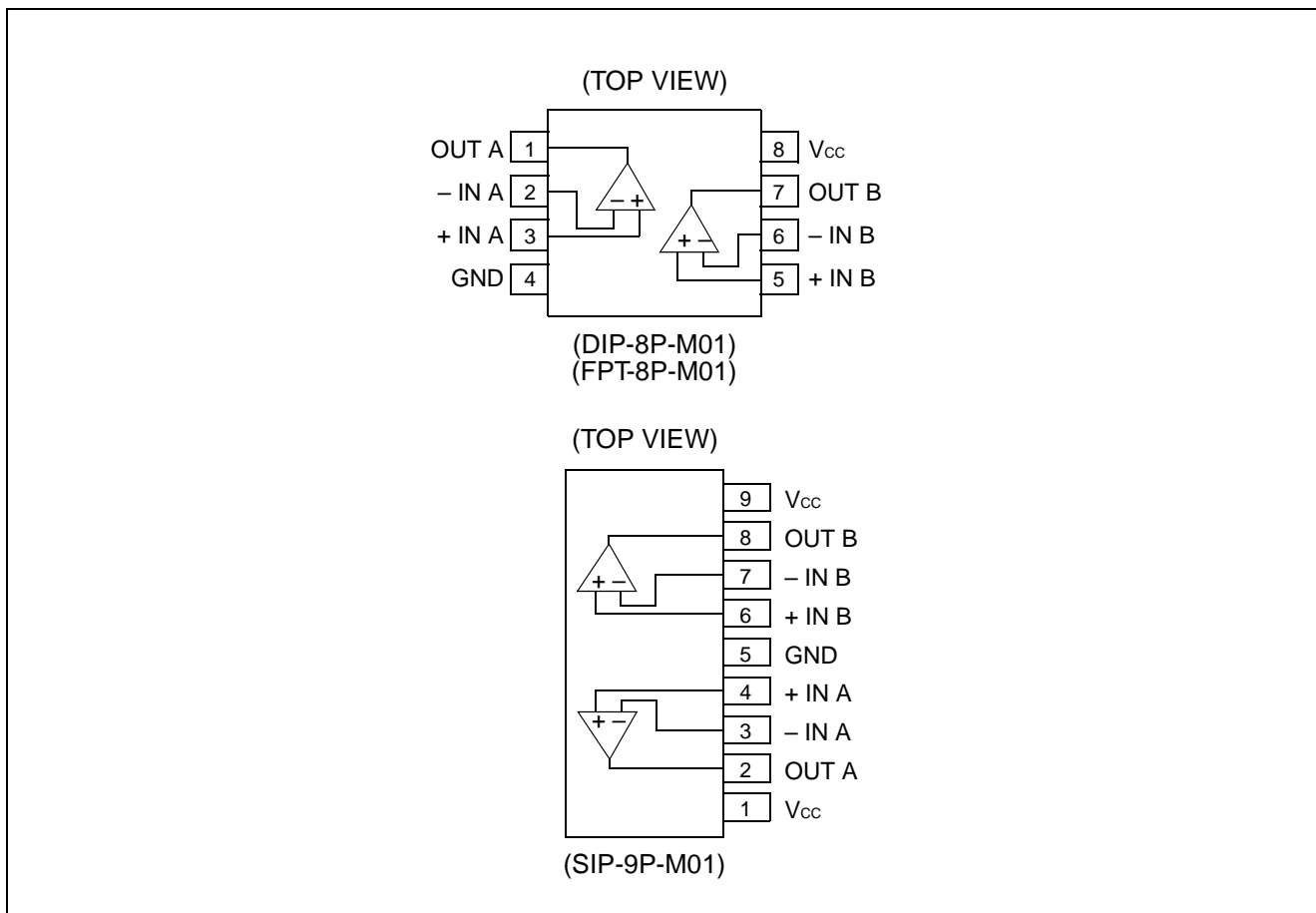

■ ABSOLUTE MAXIMUM RATINGS (see NOTE)

T_a = 25°C

Rating	Symbol	Value	Unit
Power Supply Voltage	V _{CC}	36	V
Differential Input Voltage	V _{ID}	36	V
Common-Mode Input Voltage	V _I	-5 to +36	V
Output Short Current to GND	—	Infinite*	—
Power Dissipation	P _D	350 (T _a 55°C)	mW
Operating Temperature	T _a	-20 to +75	°C
Storage Temperature	T _{STG}	-55 to +125	°C

* : This value is specified with respect to the short circuit from output to GND. However, short circuit from the output to V_{CC} cause device destruction.

Note: Permanent device damage may occur if the above Absolute Maximum Ratings are exceeded. Functional operation should be restricted to the conditions as detailed in the operational sections of this data sheet. Exposure to absolute maximum rating conditions for extended periods may affect device reliability.

Figure 1 MB47393 EQUIVALENT CIRCUIT

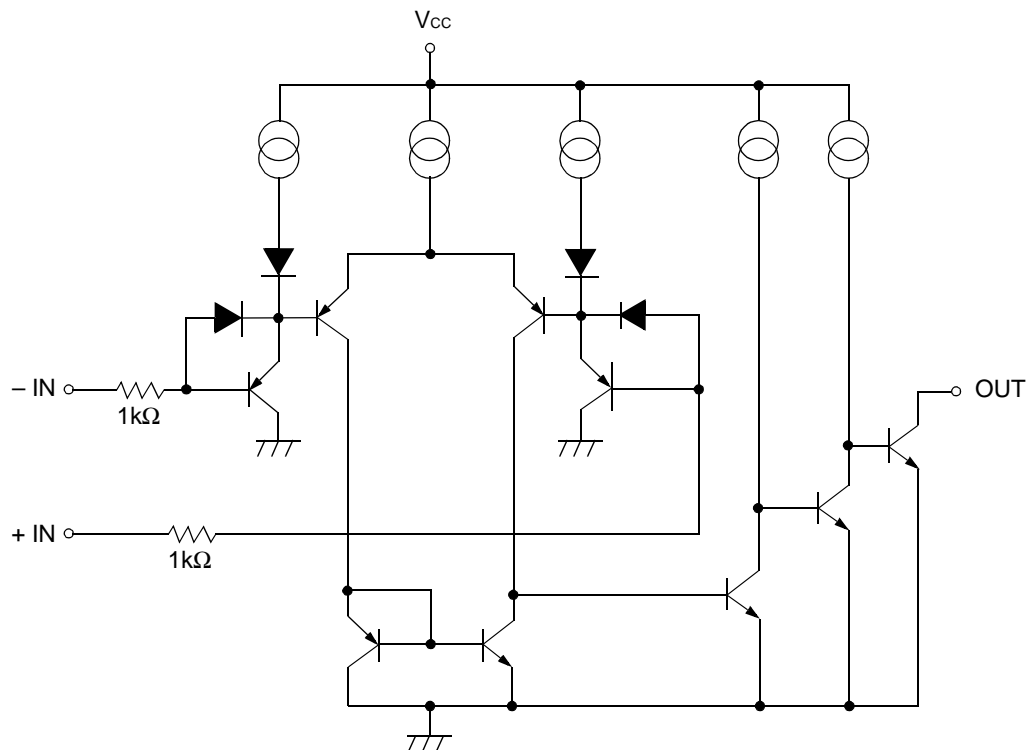

RECOMMENDED OPERATING CONDITIONS

Parameter	Symbol	Value	Unit
Power Supply Voltage	V_{CC}	2 to 30	V
		± 1.0 to ± 15	
Operating Temperature	T_a	-20 to +75	$^{\circ}\text{C}$
Output Sink Current	I_{SINK}	40	mA

MB47393

ELECTRICAL CHARACTERISTICS

($T_a = 25^\circ\text{C}$, $V_{CC} = 5\text{V}$)

Parameter	Symbol	Condition	Value			Unit
			Min.	Typ.	Max.	
Input Offset Voltage	V_{IO}	$V_O = V_{REF} = 1.4\text{V}$	—	2	5	mV
Input Offset Current	I_{IO}	—	—	5	50	nA
Input Bias Current	I_{IN*1}	—	—	25	250	nA
Common-Mode Input Voltage	V_{CM*2}	—	0	—	$V_{CC}-1.5$	V
Power Supply Current	I_{CC}	$R_L = \infty$	—	2	3	mA
Voltage Gain	A_v	$R_L = 15\text{k}\Omega$, $V_{CC} = 15\text{V}$	—	200	—	V/mV
Response Time	—	$R_L = 1\text{k}\Omega$	—	2	—	μs
Output Sink Current	I_{SINK}	$V_{IN(+)} = 0$, $V_{IN(-)} = 1\text{V}$, $V_{OL} \geq 1.5\text{V}$	40	—	—	mA
Output Saturation Voltage	V_{OL}	$V_{IN(+)} = 0$, $V_{IN(-)} = 1\text{V}$, $I_{SINK} = 30\text{mA}$	—	0.2	0.4	V
Output Leakage Current	I_{LEAK}	$V_{IN(+)} = 1\text{V}$, $V_{IN(-)} = 0\text{V}$, $V_O = 30\text{V}$	—	—	1	μA

Notes:

- *1: I_{IN} is measured when $V_I \approx 0$ and direction of the input current flows from IC. When negative voltage is applied to input pin, the pin is equivalently connected the GND through a $1\text{k}\Omega$ of resistor. When low voltage below than -5V is applied, please connect a resistor serially to input pin in order to prevent the high current flow.
- *2: Positive input voltage may exceed the power supply voltage. As long as the other voltage remains in the common-mode input voltage range, the comparator will provide a proper output state. When $V_{CC} = 5\text{V}$, your are requested to use V_{IN} below 25V .

TYPICAL CHARACTERISTIC CURVES

Figure 2 POWER SUPPLY CURRENT vs POWER SUPPLY VOLTAGE

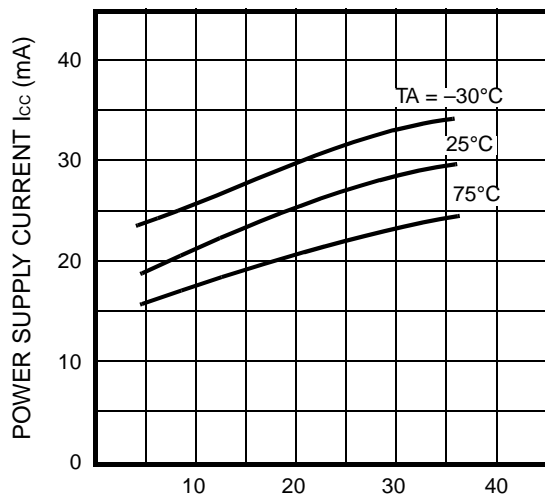
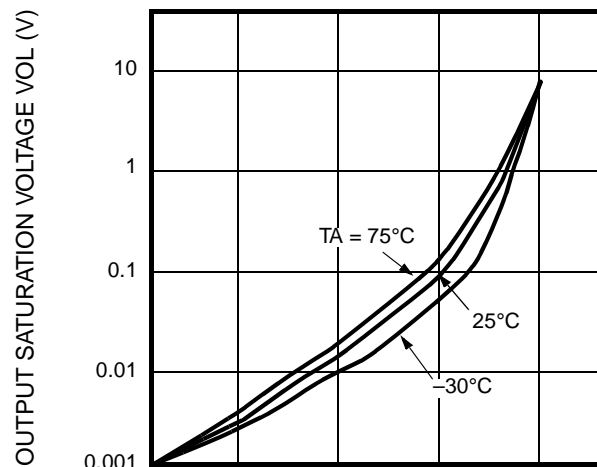

Figure 3 OUTPUT SATURATION VOLTAGE vs OUTPUT SINK CURRENT



■ TYPICAL CHARACTERISTIC CURVES (Continued)

Figure 4 INPUT CURRENT vs INPUT VOLTAGE

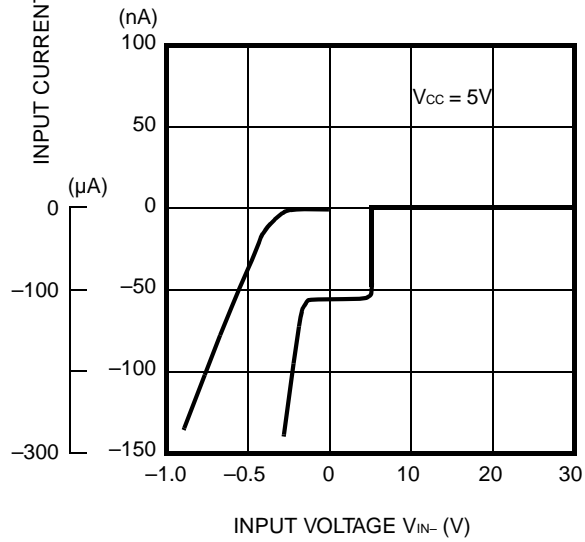

Figure 5 INPUT VOLTAGE/OUTPUT VOLTAGE vs RESPONSE TIME

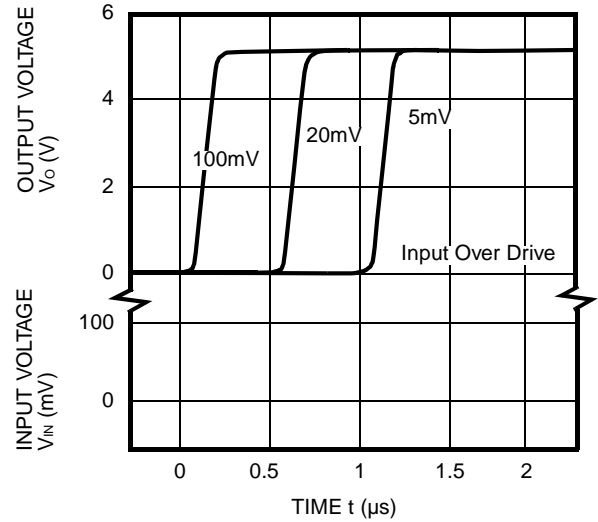

Figure 6 INPUT VOLTAGE/OUTPUT VOLTAGE vs RESPONSE TIME

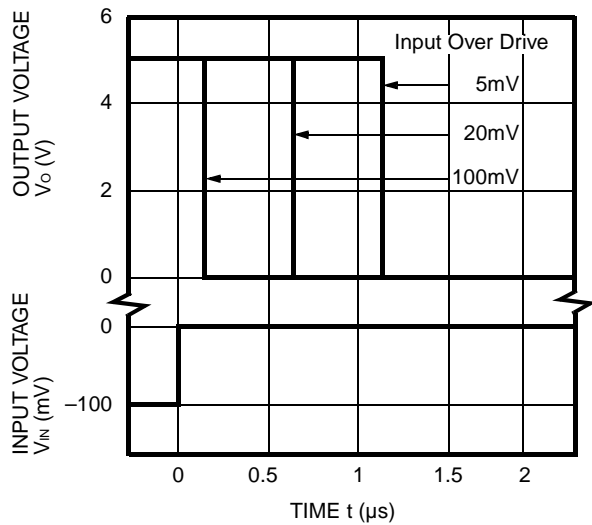
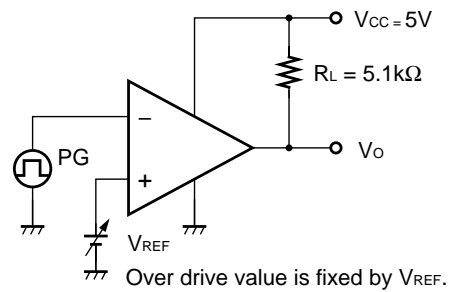
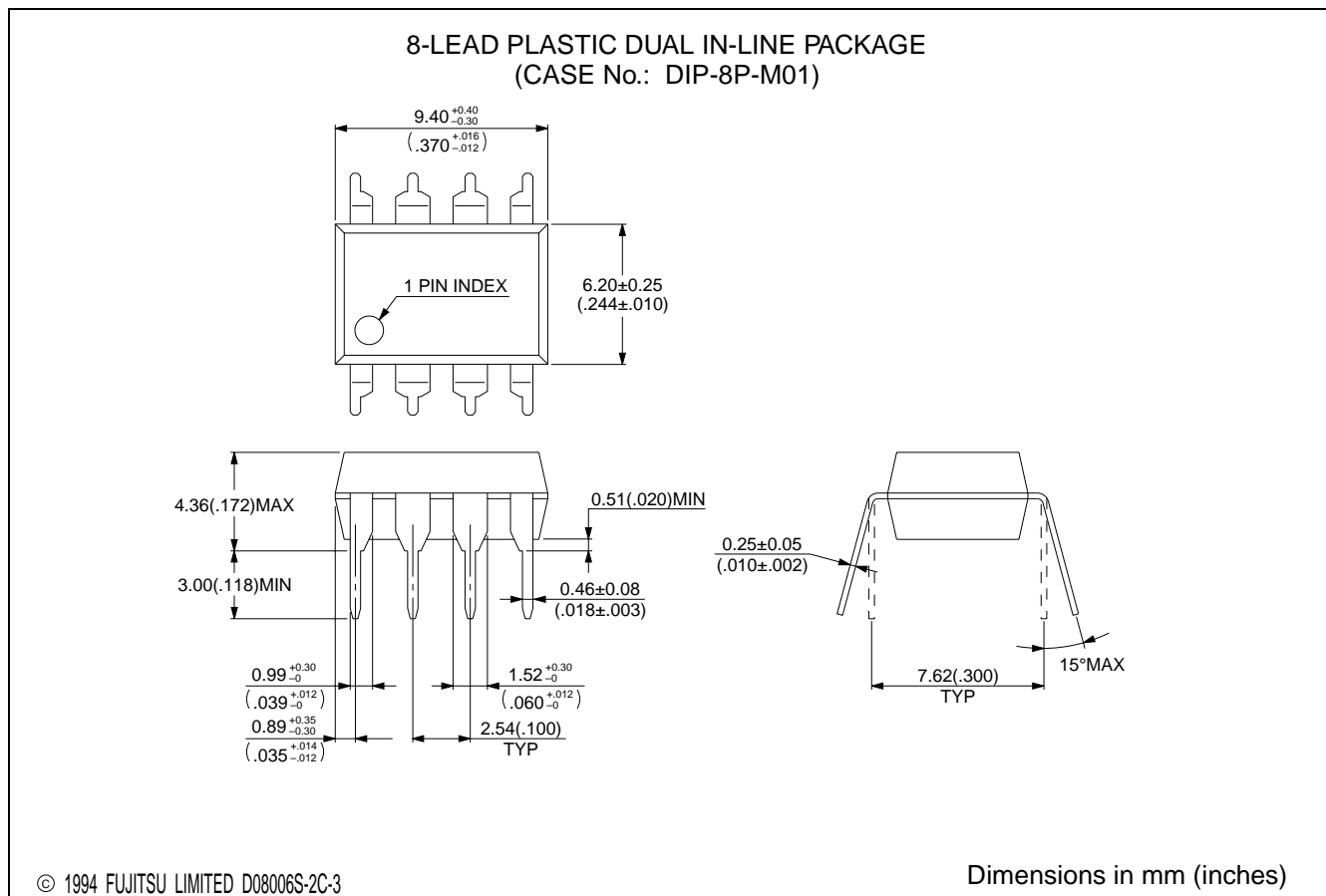

Figure 7 TEST CIRCUIT



MB47393

■ PACKAGE DIMENSIONS



■ PACKAGE DIMENSIONS (Continued)

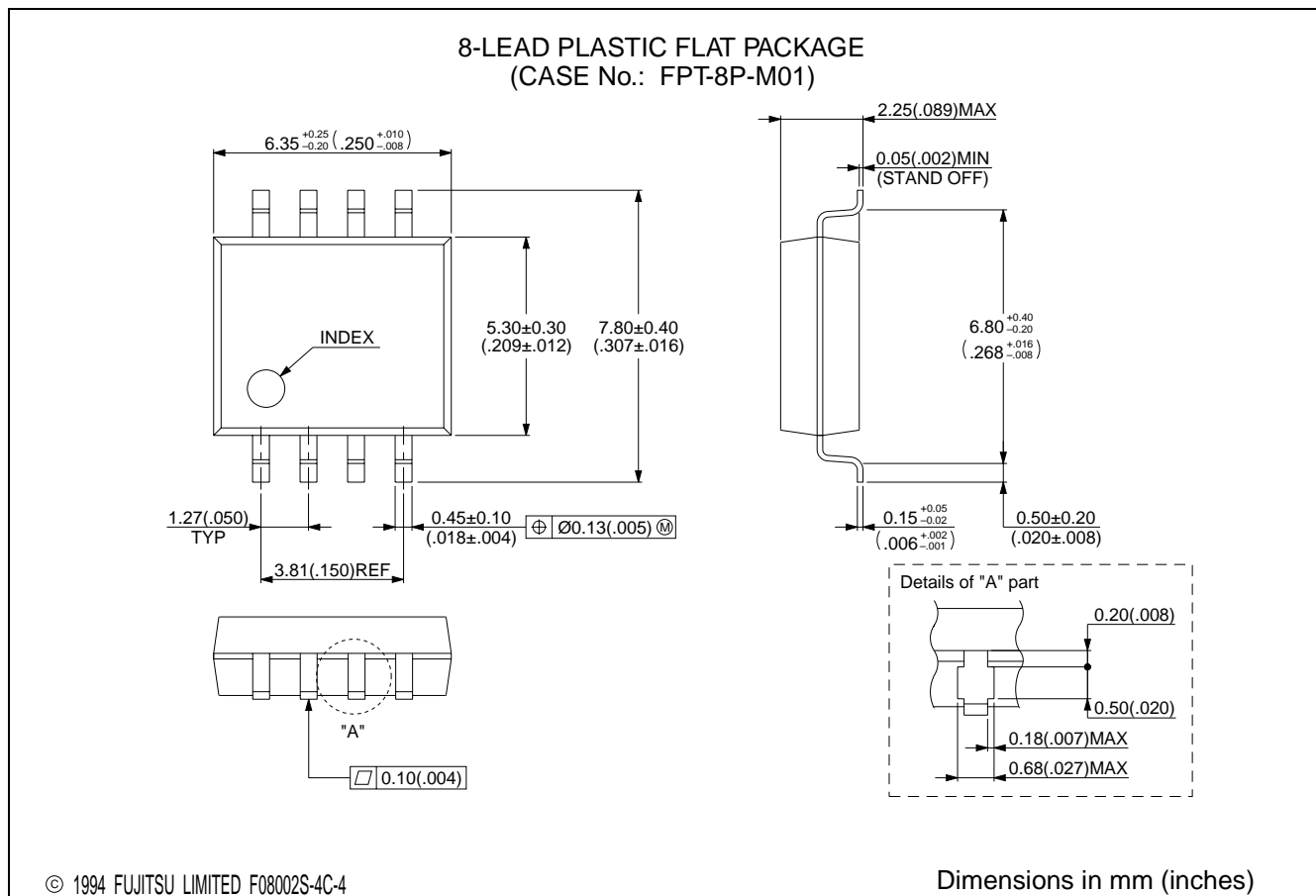

MB47393

■ PACKAGE DIMENSIONS (Continued)

9-LEAD PLASTIC SINGLE IN-LINE PACKAGE
(CASE No.: SIP-9P-M01)

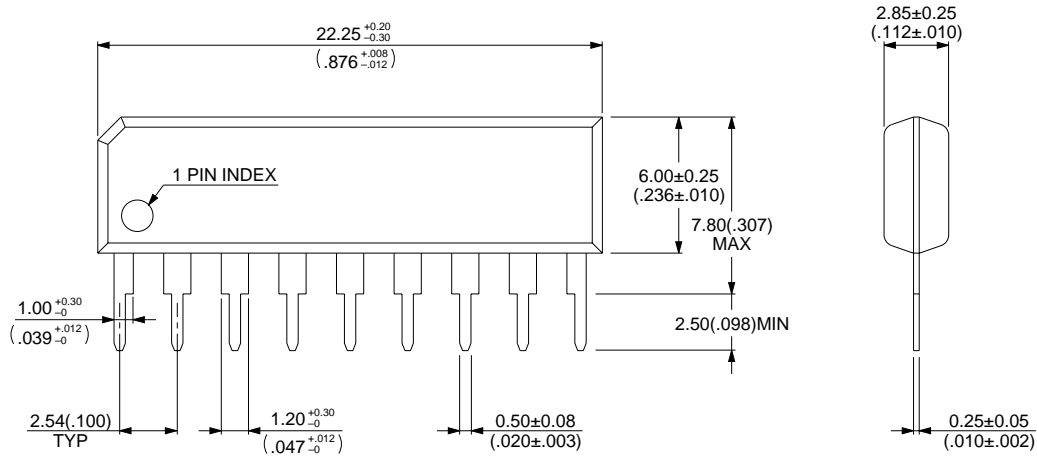

© 1994 FUJITSU LIMITED S09002S-3C-3

Dimensions in mm (inches)

FUJITSU LIMITED

For further information please contact:

Japan

FUJITSU LIMITED
Corporate Global Business Support Division
Electronic Devices
KAWASAKI PLANT, 4-1-1, Kamikodanaka
Nakahara-ku, Kawasaki-shi
Kanagawa 211-88, Japan
Tel: (044) 754-3763
Fax: (044) 754-3329

North and South America

FUJITSU MICROELECTRONICS, INC.
Semiconductor Division
3545 North First Street
San Jose, CA 95134-1804, U.S.A.
Tel: (408) 922-9000
Fax: (408) 432-9044/9045

Europe

FUJITSU MIKROELEKTRONIK GmbH
Am Siebenstein 6-10
63303 Dreieich-Buchsschlag
Germany
Tel: (06103) 690-0
Fax: (06103) 690-122

Asia Pacific

FUJITSU MICROELECTRONICS ASIA PTE. LIMITED
#05-08, 151 Lorong Chuan
New Tech Park
Singapore 556741
Tel: (65) 281-0770
Fax: (65) 281-0220

All Rights Reserved.

The contents of this document are subject to change without notice. Customers are advised to consult with FUJITSU sales representatives before ordering.

The information and circuit diagrams in this document presented as examples of semiconductor device applications, and are not intended to be incorporated in devices for actual use. Also, FUJITSU is unable to assume responsibility for infringement of any patent rights or other rights of third parties arising from the use of this information or circuit diagrams.

FUJITSU semiconductor devices are intended for use in standard applications (computers, office automation and other office equipment, industrial, communications, and measurement equipment, personal or household devices, etc.).

CAUTION:

Customers considering the use of our products in special applications where failure or abnormal operation may directly affect human lives or cause physical injury or property damage, or where extremely high levels of reliability are demanded (such as aerospace systems, atomic energy controls, sea floor repeaters, vehicle operating controls, medical devices for life support, etc.) are requested to consult with FUJITSU sales representatives before such use. The company will not be responsible for damages arising from such use without prior approval.

Any semiconductor devices have inherently a certain rate of failure. You must protect against injury, damage or loss from such failures by incorporating safety design measures into your facility and equipment such as redundancy, fire protection, and prevention of over-current levels and other abnormal operating conditions.

If any products described in this document represent goods or technologies subject to certain restrictions on export under the Foreign Exchange and Foreign Trade Control Law of Japan, the prior authorization by Japanese government should be required for export of those products from Japan.

F9703

© FUJITSU LIMITED Printed in Japan