

DALLAS

SEMICONDUCTOR

DS1231/S

Power Monitor Chip

FEATURES

- Warns processor of an impending power failure
- Provides time for an orderly shutdown
- Prevents processor from destroying nonvolatile memory during power transients
- Automatically restarts processor after power is restored
- Suitable for linear or switching power supplies
- Adjusts to hold time of the power supply
- Supplies necessary signals for processor interface
- Accurate 5% or 10% V_{CC} monitoring
- Replaces power-up reset circuitry
- No external capacitors required
- Optional 16-pin SOIC surface mount package

DESCRIPTION

The DS1231 Power Monitor Chip uses a precise temperature-compensated reference circuit which provides an orderly shutdown and an automatic restart of a processor-based system. A signal warning of an impending power failure is generated well before regulated DC voltages go out of specification by monitoring high voltage inputs to the power supply regulators. If line isolation is required a UL-approved opto-isolator can be directly interfaced to the DS1231. The time for processor

PIN ASSIGNMENT

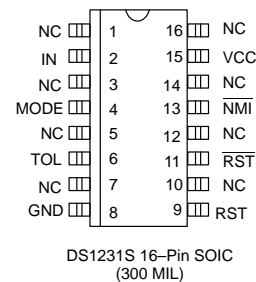
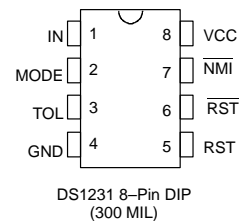

PIN DESCRIPTION

IN	– Input
MODE	– Selects input pin characteristics
TOL	– Selects 5% or 10% V_{CC} detect
GND	– Ground
RST	– Reset (Active High)
$\overline{\text{RST}}$	– Reset (Active Low, open drain)
$\overline{\text{NMI}}$	– Non-Maskable Interrupt
V_{CC}	– +5V Supply
NC	– No Connections

shutdown is directly proportional to the available hold-up time of the power supply. Just before the hold-up time is exhausted, the Power Monitor unconditionally halts the processor to prevent spurious cycles by enabling Reset as V_{CC} falls below a selectable 5 or 10 percent threshold. When power returns, the processor is held inactive until well after power conditions have stabilized, safeguarding any nonvolatile memory in the system from inadvertent data changes.

OPERATION

The DS1231 Power Monitor detects out-of-tolerance power supply conditions and warns a processor-based system of impending power failure. The main elements of the DS1231 are illustrated in Figure 1. As shown, the DS1231 actually has two comparators, one for monitoring the input (Pin 1) and one for monitoring V_{CC} (Pin 8). The V_{CC} comparator outputs the signals \overline{RST} (Pin 5) and \overline{RST} (Pin 6) when V_{CC} falls below a preset trip level as defined by TOL (Pin 3).

When TOL is connected to ground, the \overline{RST} and \overline{RST} signals will become active as V_{CC} goes below 4.75 volts. When TOL is connected to V_{CC} , the \overline{RST} and \overline{RST} signals become active as V_{CC} goes below 4.5 volts. The \overline{RST} and \overline{RST} signals are excellent control signals for a microprocessor, as processing is stopped at the last possible moments of valid V_{CC} . On power-up, \overline{RST} and \overline{RST} are kept active for a minimum of 150 ms to allow the power supply to stabilize (see Figure 2).

The comparator monitoring the input pin produces the \overline{NMI} signal (Pin 7) when the input threshold voltage (V_{TP}) falls to a level as determined by Mode (Pin 2). When the Mode pin is connected to V_{CC} , detection occurs at V_{TP-} . In this mode Pin 1 is an extremely high impedance input allowing for a simple resistor voltage divider network to interface with high voltage signals. When the Mode pin is connected to ground, detection occurs at V_{TP+} . In this mode Pin 1 sources 30 μ A of current allowing for connection to switched inputs, such as a UL-approved opto-isolator. The flexibility of the input pin allows for detection of power loss at the earliest point in a power supply system, maximizing the amount of time allotted between \overline{NMI} and \overline{RST} . On power-up, \overline{NMI} is released as soon as the input threshold voltage (V_{TP}) is achieved and V_{CC} is within nominal limits. In both

modes of operation the input pin has hysteresis for noise immunity (Figure 3).

APPLICATION – MODE PIN CONNECTED TO V_{CC}

When the Mode pin is connected to V_{CC} , pin 1 is a high impedance input. The voltage sense point and the level of voltage at the sense point are dependent upon the application (Figure 4). The sense point may be developed from the AC power line by rectifying and filtering the AC. Alternatively, a DC voltage level may be selected which is closer to the AC power input than the regulated +5-volt supply, so that ample time is provided for warning before regulation is lost.

Proper operation of the DS1231 requires a maximum voltage of 5 volts at the input (Pin 1), which must be derived from the maximum voltage at the sense point. This is accomplished with a simple voltage divider network of R1 and R2. Since the IN trip point V_{TP-} is 2.3 volts (using the -20 device), and the maximum allowable voltage on pin 1 is 5 volts, the dynamic range of voltage at the sense point is set by the ratio of $2.3/5.0 = .46$ min. This ratio determines the maximum deviation between the maximum voltage at the sense point and the actual voltage which will generate \overline{NMI} .

Having established the desired ratio, and confirming that the ratio is greater than .46 and less than 1, the proper values for R1 and R2 can be determined by the equation as shown in Figure 4. A simple approach to solving this equation is to select a value for R2 which is high enough impedance to keep power consumption low, and solve for R1. Figure 5 illustrates how the DS1231 can be interfaced to the AC power line when the mode pin is connected to V_{CC} .

POWER MONITOR BLOCK DIAGRAM Figure 1

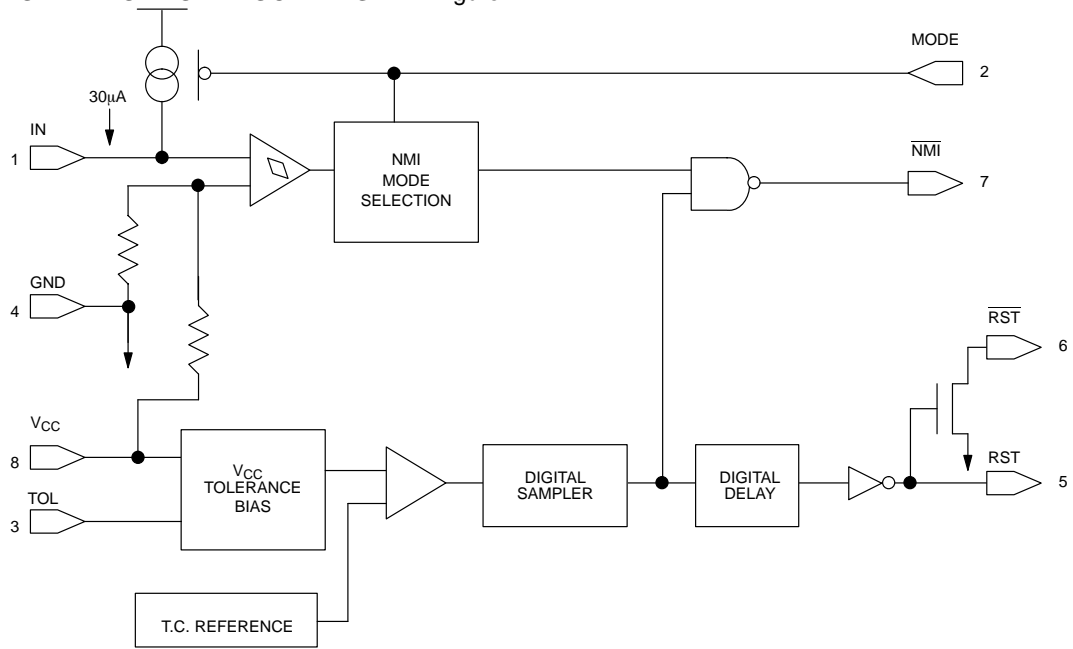

POWER-UP RESET Figure 2

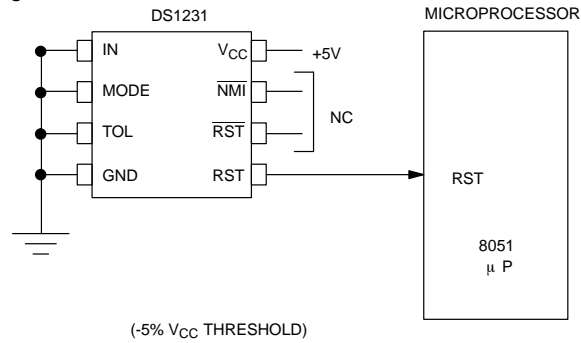

INPUT PIN HYSTERESIS Figure 3

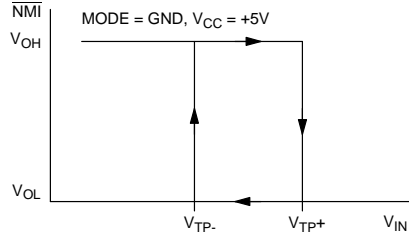

	-20	-35	-50
V _{TP-}	2.3	2.15	2.0
V _{TP+}	2.5	2.5	2.5

NOTE: HYSTERESIS TOLERANCE IS ±60 mV

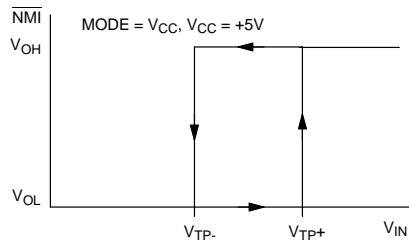

APPLICATION WITH MODE PIN CONNECTED TO V_{CC} Figure 4

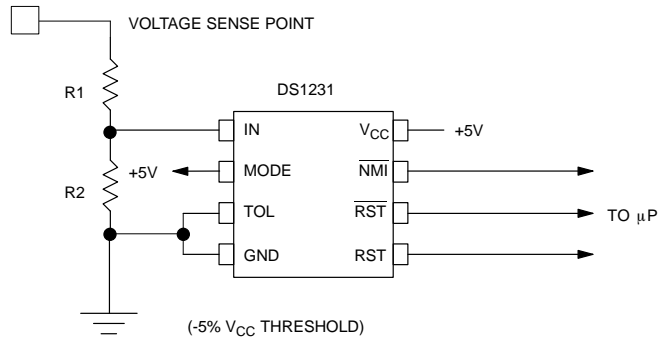

$$V \text{ SENSE} = \frac{R1 + R2}{R2} \times 2.3 \quad V \text{ MAX} = \frac{V \text{ SENSE}}{V_{TP-}} \times 5.0$$

EXAMPLE: V SENSE = 8 VOLTS AT TRIP POINT AND A
MAXIMUM VOLTAGE OF 17.5V WITH R2 = 10K

$$\text{THEN } 8 = \frac{R1 + 10K}{10K} \times 2.3 \quad R1 = 25K$$

NOTE: $\overline{\text{RST}}$ requires a pull-up resistor.

APPLICATION – MODE PIN CONNECTED TO GROUND

When the Mode pin is connected to ground, pin 1 is a current source of $30\ \mu\text{A}$ with a V_{TP+} of 2.5 volts. Pin 1 is held below the trip point by a switching device like an opto-isolator as shown in Figure 6. Determination of the sense point has the same criteria as discussed in the previous application. However, determining component values is significantly different. In this mode, the maximum dynamic range of the sense point versus desired trip voltage is primarily determined by the selection of a zener diode. As an example, if the maximum voltage at the sense point is 200V and the desired trip point is 150V, then a zener diode of 150V will approximately set

the trip point. This is particularly true if power consumption on the high voltage side of the opto-isolator is not an issue. However, if power consumption is a concern, then it is desirable to make the value of R1 high. As the value of R1 increases, the effect of the LED current in the opto-isolator starts to affect the IN trip point. This can be seen from the equation shown in Figure 6. R1 must also be low enough to allow the opto-isolator to sink the $30\ \mu\text{A}$ of collector current required by pin 1 and still have enough resistance to keep the maximum current through the opto-isolator's LED within data sheet limits. Figure 7 illustrates how the DS1231 can be interfaced to the AC power line when the mode pin is grounded.

AC VOLTAGE MONITOR WITH TRANSFORMER ISOLATION Figure 5

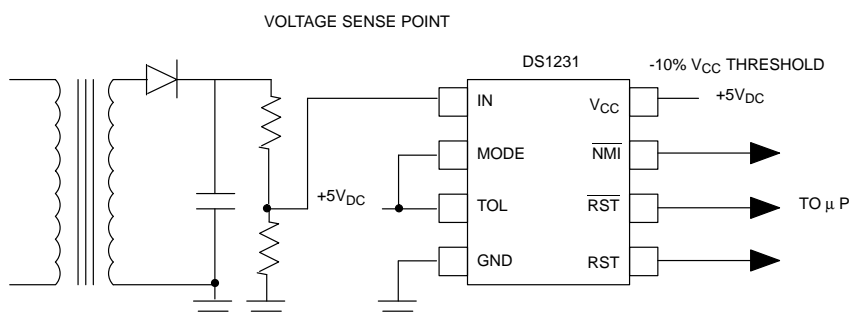

NOTE: $\overline{\text{RST}}$ requires a pull-up resistor.

APPLICATION WITH MODE PIN GROUNDED Figure 6

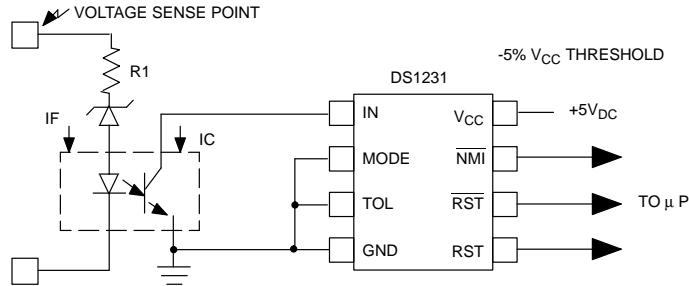

$$\text{VOLTAGE SENSE POINT (TRIP VALUE)} = V_Z + \frac{I_C}{CTR} \times R_1$$

$$CTR = \frac{I_C}{I_F} \quad CTR = \text{CURRENT TRANSFER RATIO}$$

$$V_Z = \text{ZENNER VOLTAGE}$$

EXAMPLE: CTR = 0.2 IC = 30 μA IF = 150 μA
 VOLTAGE SENSE POINT = 105 AND
 VZ = 100 VOLTS

$$\text{THEN } 105 = 100 + \frac{30}{0.2} \times R_1 \quad R_1 = 33K$$

NOTE: \overline{RST} requires a pull-up resistor.

AC VOLTAGE MONITOR WITH OPTO-ISOLATION Figure 7

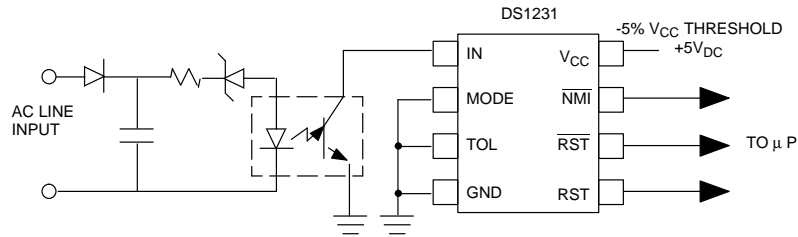

NOTE: \overline{RST} requires a pull-up resistor.

ABSOLUTE MAXIMUM RATINGS*

Voltage on V_{CC} Pin Relative to Ground	-0.5V to +7.0V
Voltage on I/O Relative to Ground	-0.5V to $V_{CC} + 0.5V$
Operating Temperature	0°C to 70°C
Operating Temperature (Industrial Version)	-40°C to +85°C
Storage Temperature	-55°C to +125°C
Soldering Temperature	260°C for 10 seconds

* This is a stress rating only and functional operation of the device at these or any other conditions above those indicated in the operation sections of this specification is not implied. Exposure to absolute maximum rating conditions for extended periods of time may affect reliability.

RECOMMENDED DC OPERATING CONDITIONS

(0°C to 70°C)

PARAMETER	SYMBOL	MIN	TYP	MAX	UNITS	NOTES
Supply Voltage	V_{CC}	4.5	5.0	5.5	V	1
Input Pin 1	V_{IN}			V_{CC}	V	1

DC ELECTRICAL CHARACTERISTICS(0°C to 70°C; $V_{CC} = 4.5$ to 5.5V)

PARAMETER	SYMBOL	MIN	TYP	MAX	UNITS	NOTES
Low Level @ RST	V_{OL}			0.4	V	1
Output Voltage @ -500 μ A	V_{OH}	$V_{CC}-0.5V$	$V_{CC}-0.1V$		V	1, 6
Input Leakage	I_{IL}	-10		+10	μ A	2
Output Current @2.4V	I_{OH}	1.0	2.0		mA	5
Output Current @0.4V	I_{OL}	2.0	3.0		mA	
Operating Current	I_{CC}		0.5	2.0	mA	3
Input Pin 1 (Mode=GND)	I_C	15	25	50	μ A	
Input Pin 1 (Mode= V_{CC})	I_C			0.1	μ A	
IN Trip Piont (Mode=GND)	V_{TP}	See Figure 3				1
IN Trip Point (Mode= V_{CC})	V_{TP}					1
V_{CC} Trip Point (TOL=GND)	V_{CCTP}	4.50	4.62	4.74	V	1
V_{CC} Trip Point (TOL= V_{CC})	V_{CCTP}	4.25	4.37	4.49	V	1

CAPACITANCE $(T_A = 25^\circ\text{C})$

PARAMETER	SYMBOL	MIN	TYP	MAX	UNITS	NOTES
Input Capacitance	C_{IN}			5	pF	
Output Capacitance	C_{OUT}			7	pF	

AC ELECTRICAL CHARACTERISTICS(0°C to 70°C; $V_{CC} = 5V \pm 10\%$)

PARAMETER	SYMBOL	MIN	TYP	MAX	UNITS	NOTES
V_{TP} to \overline{NMI} Delay	t_{IPD}			1.1	μs	
V_{CC} Slew Rate 4.75-4.25V	t_F	300			μs	
V_{CC} Detect to RST and \overline{RST}	t_{RPD}			100	ns	
V_{CC} Detect to \overline{NMI}	t_{IPU}			200	μs	4
V_{CC} Detect to RST and \overline{RST}	t_{RPU}	150	500	1000	ms	4
V_{CC} Slew Rate 4.25-4.75V	t_R	0			ns	

NOTES:

- All voltages referenced to ground.
- $V_{CC} = +5.0$ volts with outputs open.
- Measured with outputs open.
- $t_R = 5 \mu s$.
- \overline{RST} is an open drain output and requires a pull-up resistor.
- RST remains within 0.5V of V_{CC} on power-down until V_{CC} drops below 2.0V. \overline{RST} remains within 0.5V of GND on power-down until V_{CC} drops below 2.0V.

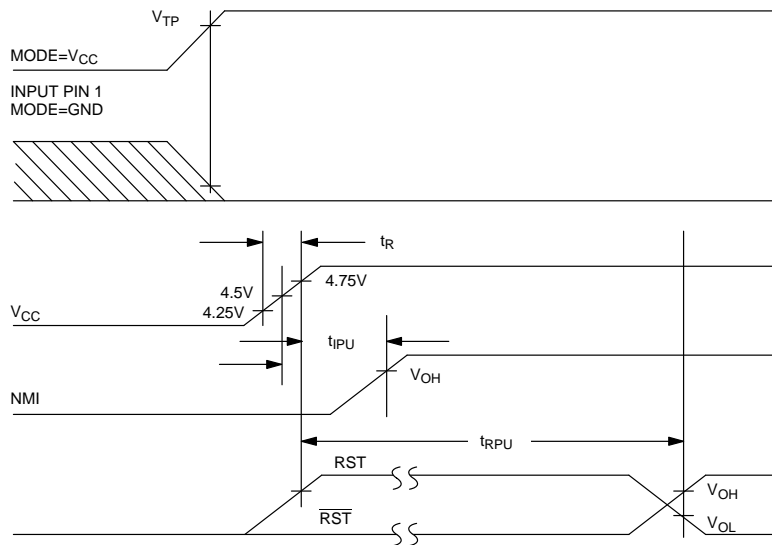
TIMING DIAGRAM: POWER-UP

TIMING DIAGRAM: POWER-DOWN

