

MC12015 MC12016 MC12017

Dual Modulus Prescaler

The MC12015, MC12016 and MC12017 are dual modulus prescalers which will divide by 32 and 33, 40 and 41, and 64 and 65, respectively. An internal regulator is provided to allow these devices to be used over a wide range of power-supply voltages. The devices may be operated by applying a supply voltage of 5.0 Vdc $\pm 10\%$ at Pin 7, or by applying an unregulated voltage source from 5.5Vdc to 9.5 Vdc to Pin 8.

- 225 MHz Toggle Frequency
- Low-Power 7.5 mA Maximum at 6.8 V
- Control Input and Output Are Compatible With Standard CMOS
- Connecting Pins 2 and 3 Allows Driving One TTL Load
- Supply Voltage 4.5 V to 9.5 V

MECL PLL COMPONENTS DUAL MODULUS PRESCALER

SEMICONDUCTOR TECHNICAL DATA



D SUFFIX
PLASTIC PACKAGE
CASE 751
(SO-8)

ORDERING INFORMATION

Device	Operating Temperature Range	Package
MC12015D	$T_A = -40$ to 85°C	SO-8
MC12016D		
MC12017D		

SIMPLIFIED BLOCK DIAGRAM

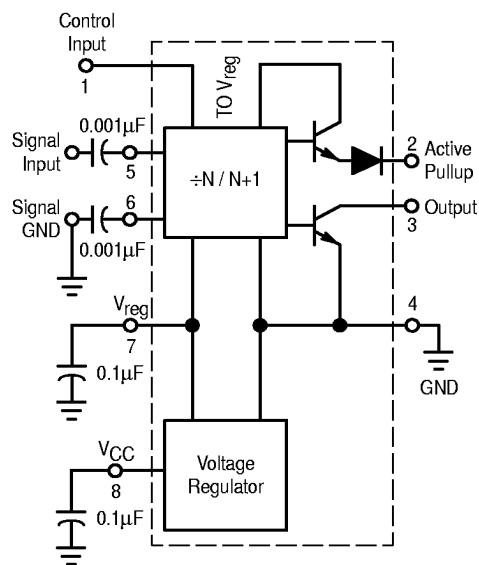

1. V_{reg} at Pin 7 is not guaranteed to be between 4.5 and 5.5V when V_{CC} is being applied to Pin 8
2. Pin 7 is not to be used as a source of regulated output voltage

MC12015 MC12016 MC12017

MAXIMUM RATINGS [tblhead]

Rating	Symbol	Value	Unit
Regulated Voltage, Pin 7	V_{reg}	8.0	Vdc
Power Supply Voltage, Pin 8	V_{CC}	10	Vdc
Operating Temperature Range	T_A	-40 to +85	°C
Storage Temperature Range	T_{stg}	-65 to +175	°C

NOTE: ESD data available upon request.

ELECTRICAL CHARACTERISTICS ($V_{CC} = 5.5$ to 9.5 V; $V_{reg} = 4.5$ to 5.5 V; $T_A = -40$ to 85°C , unless otherwise noted.)

Characteristic	Symbol	Min	Typ	Max	Unit
Toggle Frequency (Sine Wave Input)	f_{max}	225	–	–	MHz
	f_{min}	–	–	35	
Supply Current	I_{CC}	–	6.0	7.8	mA
Control Input HIGH ($\div 32, 40$ or 64)	V_{IH}	2.0	–	–	V
Control Input LOW ($\div 33, 41$ or 65)	V_{IL}	–	–	0.8	V
Output Voltage HIGH ($I_{source} = 50\mu\text{A}$) [Note 1]	V_{OH}	2.5	–	–	V
Output Voltage LOW ($I_{sink} = 2\text{mA}$) [Note 1]	V_{OL}	–	–	0.5	V
Input Voltage Sensitivity	V_{in}				mVpp
35 MHz		400	–	800	
50 to 225 MHz		200	–	800	
PLL Response Time [Notes 2 and 3]	t_{PLL}	–	–	t_{out} to 70	ns

NOTES: 1. Pin 2 connected to Pin 3.

2. t_{PLL} = the period of time the PLL has from the prescaler rising output transition (50%) to the modulus control input edge transition (50%) to ensure proper modulus selection.

3. t_{out} = period of output waveform.

MC12015 MC12016 MC12017

OUTLINE DIMENSIONS

D SUFFIX
 PLASTIC PACKAGE
 CASE 751-06
 (SO-8)
 ISSUE T

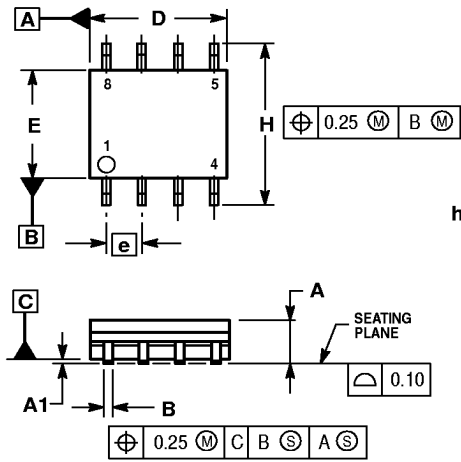

NOTES:

1. DIMENSIONING AND TOLERANCING PER ASME Y14.5M, 1994.
2. DIMENSIONS ARE IN MILLIMETER.
3. DIMENSION D AND E DO NOT INCLUDE MOLD PROTRUSION.
4. MAXIMUM MOLD PROTRUSION 0.15 PER SIDE.
5. DIMENSION B DOES NOT INCLUDE DAMBAR PROTRUSION. ALLOWABLE DAMBAR PROTRUSION SHALL BE 0.127 TOTAL IN EXCESS OF THE B DIMENSION AT MAXIMUM MATERIAL CONDITION.

MILLIMETERS		
DIM	MIN	MAX
A	1.35	1.75
A1	0.10	0.25
B	0.35	0.49
C	0.19	0.25
D	4.80	5.00
E	3.80	4.00
e	1.27 BSC	
H	5.80	6.20
h	0.25	0.50
L	0.40	1.25
θ	0°	7°