



# 1.1 GHz Super Low Power Dual Modulus Prescaler

The MC12052A is a super low power dual modulus prescaler used in phase-locked loop applications. Motorola's advanced Bipolar MOSAIC™ V technology is utilized to achieve low power dissipation of 2.7 mW at a minimum supply voltage of 2.7 V.

The MC12052A can be used with CMOS synthesizers requiring positive edges to trigger internal counters such as Motorola's MC145XXX series in a PLL to provide tuning signals up to 1.1 GHz in programmable frequency steps.

A Divide Ratio Control (SW) permits selection of a 64/65 or 128/129 divide ratio as desired.

The Modulus Control (MC) selects the proper divide number after SW has been biased to select the desired divide ratio.

- 1.1 GHz Toggle Frequency
- The MC12052 is Pin and Functionally Compatible with the MC12022
- Low Power 1.0 mA Typical
- 2.0 mA Maximum,  $-40$  to  $85^{\circ}\text{C}$ ,  $V_{CC} = 2.7$  to  $5.5$  Vdc
- Short Setup Time ( $t_{set}$ ) 16 ns Maximum @ 1.1 GHz
- Modulus Control Input Level is Compatible with Standard CMOS and TTL
- Maximum Input Voltage Should Be Limited to 6.5 Vdc

MOSAIC V is a trademark of Motorola

## FUNCTIONAL TABLE

SW	MC	Divide Ratio
H	H	64
H	L	65
L	H	128
L	L	129

**NOTES:** 1. SW: H =  $V_{CC}$ , L = Open. A logic L can also be applied by grounding this pin, but this is not recommended due to increased power consumption.  
2. MC: H = 2.0 V to  $V_{CC}$ , L = GND to 0.8 V.

## MAXIMUM RATINGS

Characteristic	Symbol	Range	Unit
Power Supply Voltage, Pin 2	$V_{CC}$	$-0.5$ to $7.0$	Vdc
Operating Temperature Range	$T_A$	$-40$ to $85$	$^{\circ}\text{C}$
Storage Temperature Range	$T_{stg}$	$-65$ to $150$	$^{\circ}\text{C}$
Modulus Control Input, Pin 6	MC	$-0.5$ to $6.5$	Vdc

## MC12052A

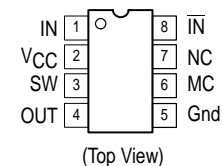
### MECL PLL COMPONENTS ÷64/65, ÷128/129 LOW POWER DUAL MODULUS PRESCALER

#### SEMICONDUCTOR TECHNICAL DATA



**D SUFFIX**  
PLASTIC PACKAGE  
CASE 751  
(SO-8)

## PIN CONNECTIONS



## ORDERING INFORMATION

Device	Operating Temp Range	Package
MC12052AD	$T_A = -40$ to $85^{\circ}\text{C}$	SO-8

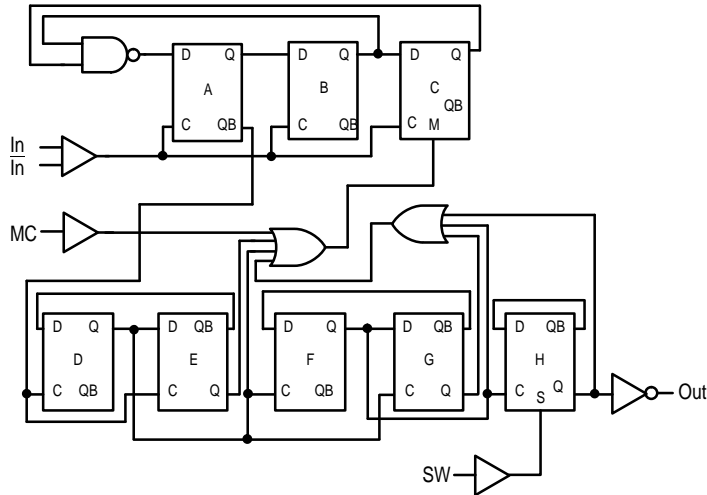
# MC12052A

**ELECTRICAL CHARACTERISTICS** ( $V_{CC} = 2.7$  to  $5.5$  VDC,  $T_A = -40$  to  $85^\circ\text{C}$ , unless otherwise noted.)

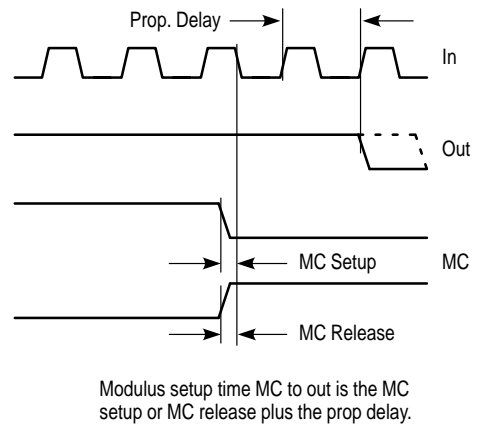
Characteristic	Symbol	Min	Typ	Max	Unit
Toggle Frequency (Sine Wave Input)	$f_t$	0.1	1.4	1.1	GHz
Supply Current (Pin 2)	$I_{CC}$	–	1.0	2.0	mA
Modulus Control Input High (MC)	$V_{IH1}$	2.0	–	$V_{CC} + 0.5$ V	V
Modulus Control Input Low (MC)	$V_{IL1}$	Gnd	–	0.8	V
Divide Ratio Control Input High (SW)	$V_{IH2}$	$V_{CC} - 0.5$ V	$V_{CC}$	$V_{CC} + 0.5$ V	VDC
Divide Ratio Control Input Low (SW)	$V_{IL2}$	Open	Open	Open	–
Output Voltage Swing (Note 2) ( $C_L = 8.0$ pF, $R_L = 3.3$ k $\Omega$ )	$V_{out}$	0.8	1.1	–	$V_{PP}$
Modulus Setup Time MC to Out @ 1100 MHz	$t_{set}$	–	11	16	ns
Input Voltage Sensitivity 250–1100 MHz 100–250 MHz	$V_{in}$	100 400	– –	1000 1000	mV $_{PP}$
Output Current (Note 1) $V_{CC} = 2.7$ V, $C_L = 8.0$ pF, $R_L = 3.3$ k $\Omega$ $V_{CC} = 5.0$ V, $C_L = 8.0$ pF, $R_L = 7.2$ k $\Omega$	$I_O$	– –	0.5 0.5	3.0 3.0	mA

**NOTES:** 1. Divide ratio of +64/65 @ 1.1 GHz  
2. Valid over voltage range 2.7 to 5.5 V;  $R_L = 3.3$  k $\Omega$  @  $V_{CC} = 2.7$  V;  $R_L = 7.2$  k $\Omega$  @  $V_{CC} = 5.0$  V

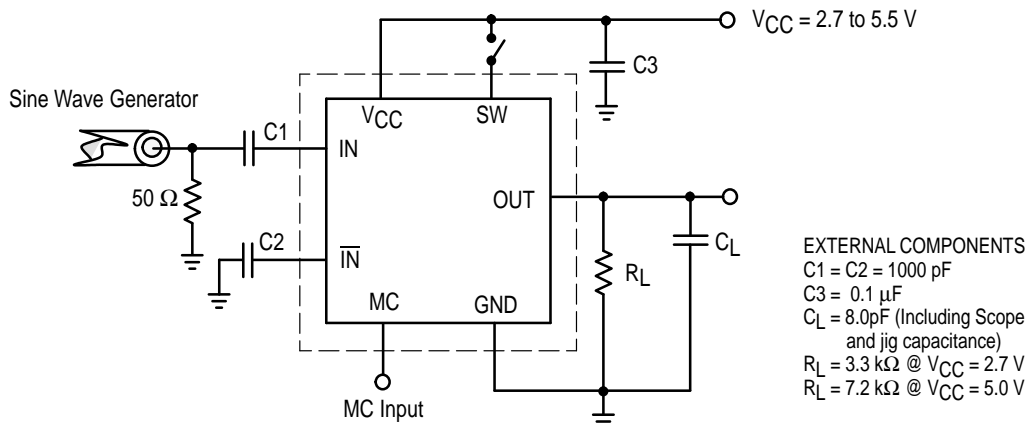
**Figure 1. Logic Diagram (MC12052A)**



**Figure 2. Modulus Setup Time**

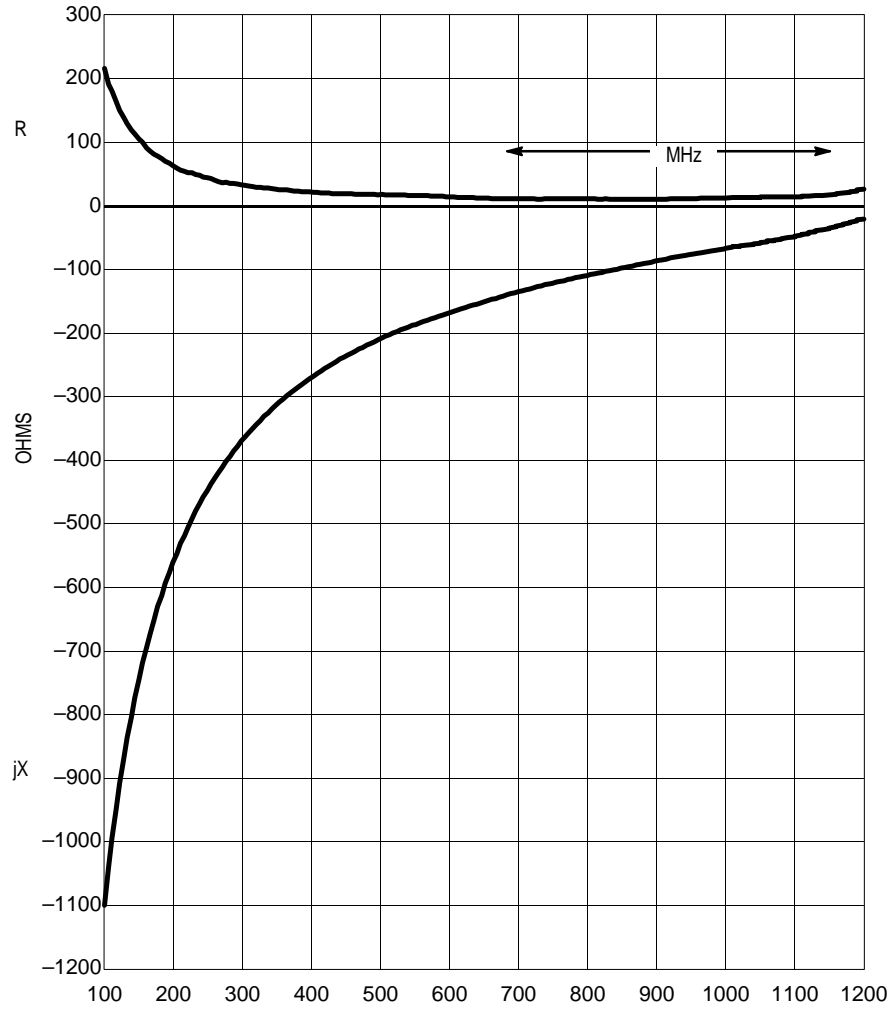


**Figure 3. AC Test Circuit**



# MC12052A

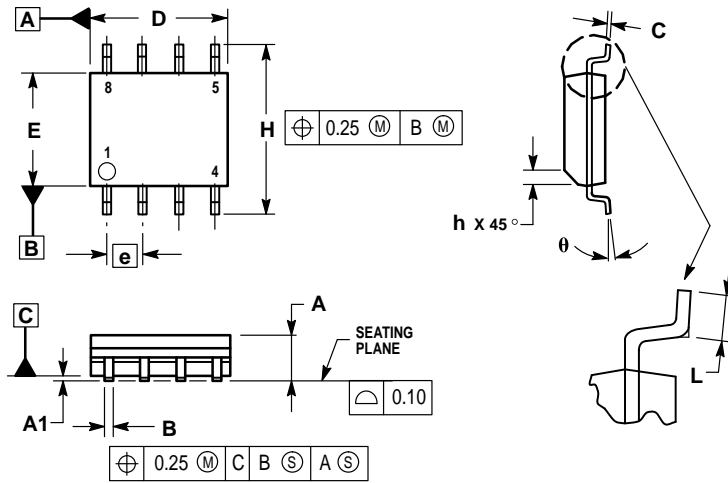
Figure 4. Typical Input Impedance versus Input Frequency



# MC12052A

## OUTLINE DIMENSIONS

D SUFFIX  
PLASTIC PACKAGE  
CASE 751-06  
(SO-8)  
ISSUE T



NOTES:

1. DIMENSIONING AND TOLERANCING PER ASME Y14.5M, 1994.
2. DIMENSIONS ARE IN MILLIMETER.
3. DIMENSION D AND E DO NOT INCLUDE MOLD PROTRUSION.
4. MAXIMUM MOLD PROTRUSION 0.15 PER SIDE.
5. DIMENSION B DOES NOT INCLUDE DAMBAR PROTRUSION. ALLOWABLE DAMBAR PROTRUSION SHALL BE 0.127 TOTAL IN EXCESS OF THE B DIMENSION AT MAXIMUM MATERIAL CONDITION.

DIM	MILLIMETERS	
	MIN	MAX
A	1.35	1.75
A1	0.10	0.25
B	0.35	0.49
C	0.19	0.25
D	4.80	5.00
E	3.80	4.00
e	1.27 BSC	
H	5.80	6.20
h	0.25	0.50
L	0.40	1.25
θ	0°	7°

Motorola reserves the right to make changes without further notice to any products herein. Motorola makes no warranty, representation or guarantee regarding the suitability of its products for any particular purpose, nor does Motorola assume any liability arising out of the application or use of any product or circuit, and specifically disclaims any and all liability, including without limitation consequential or incidental damages. "Typical" parameters which may be provided in Motorola data sheets and/or specifications can and do vary in different applications and actual performance may vary over time. All operating parameters, including "Typicals" must be validated for each customer application by customer's technical experts. Motorola does not convey any license under its patent rights nor the rights of others. Motorola products are not designed, intended, or authorized for use as components in systems intended for surgical implant into the body, or other applications intended to support or sustain life, or for any other application in which the failure of the Motorola product could create a situation where personal injury or death may occur. Should Buyer purchase or use Motorola products for any such unintended or unauthorized application, Buyer shall indemnify and hold Motorola and its officers, employees, subsidiaries, affiliates, and distributors harmless against all claims, costs, damages, and expenses, and reasonable attorney fees arising out of, directly or indirectly, any claim of personal injury or death associated with such unintended or unauthorized use, even if such claim alleges that Motorola was negligent regarding the design or manufacture of the part. Motorola and are registered trademarks of Motorola, Inc. Motorola, Inc. is an Equal Opportunity/Affirmative Action Employer.

Mfax is a trademark of Motorola, Inc.

**How to reach us:**

**USA/EUROPE/Locations Not Listed:** Motorola Literature Distribution;  
P.O. Box 5405, Denver, Colorado 80217. 1-303-675-2140 or 1-800-441-2447

**JAPAN:** Motorola Japan Ltd.; SPD, Strategic Planning Office, 141,  
4-32-1 Nishi-Gotanda, Shinagawa-ku, Tokyo, Japan. 81-3-5487-8488

**Customer Focus Center: 1-800-521-6274**

**Mfax™:** RMFAX0@email.sps.mot.com – TOUCHTONE 1-602-244-6609  
Motorola Fax Back System – US & Canada ONLY 1-800-774-1848  
– http://sps.motorola.com/mfax/

**ASIA/PACIFIC:** Motorola Semiconductors H.K. Ltd.; 8B Tai Ping Industrial Park,  
51 Ting Kok Road, Tai Po, N.T., Hong Kong. 852-26629298

**HOME PAGE:** <http://motorola.com/sps/>

