

AD421

FEATURES

- 4–20 mA Current Output**
- HART* Compatible**
- 16-Bit Resolution and Monotonicity**
- ±0.01% Integral Nonlinearity**
- 5 V or 3 V Regulator Output**
- 2.5 V and 1.25 V Precision Reference**
- 750 μ A Quiescent Current max**
- Programmable Alarm Current Capability**
- Flexible High Speed Serial Interface**
- 16-Pin TSSOP, SOIC and PDIP Packages**

GENERAL DESCRIPTION

The AD421 is a complete, loop-powered, digital to 4–20 mA converter, designed to meet the needs of smart transmitter manufacturers in the Industrial Control industry. It provides a high precision, fully integrated, low cost solution in a compact 16-pin package. The AD421 is ideal for extending the resolution of smart 4–20 mA transmitters at very low cost.

The AD421 includes a selectable regulator that is used to power itself and other devices in the transmitter. This regulator provides either a +5 V, +3.3 V or +3 V regulated output voltage. The part also contains +1.25 V and +2.5 V precision references. The AD421 thus eliminates the need for a discrete regulator and voltage reference. The only external components required are a number of passive components and a pass transistor to span large loop voltages.

The AD421 can be used with standard HART FSK protocol communication circuitry without any degradation in specified performance. The high speed serial interface is capable of operating at 10 Mbps and allows for simple connection to commonly-used microprocessors and microcontrollers via a standard three-wire serial interface.

The sigma-delta architecture of the DAC guarantees 16-bit monotonicity while the integral nonlinearity for the AD421 is $\pm 0.01\%$. The part provides a zero scale 4 mA output current with $\pm 0.1\%$ offset error and a 20 mA full-scale output current with $\pm 0.2\%$ gain error.

The AD421 is available in a 16-pin, 0.3 inch-wide, plastic DIP, a 16-lead, 0.3 inch-wide, SOIC package and in a 16-lead TSSOP package. The part is specified over the industrial temperature range of -40°C to $+85^{\circ}\text{C}$.

*HART is a trademark of the HART Communication Foundation.

†Index on Page 14.

REV. 0

Information furnished by Analog Devices is believed to be accurate and reliable. However, no responsibility is assumed by Analog Devices for its use, nor for any infringements of patents or other rights of third parties which may result from its use. No license is granted by implication or otherwise under any patent or patent rights of Analog Devices.

FUNCTIONAL BLOCK DIAGRAM

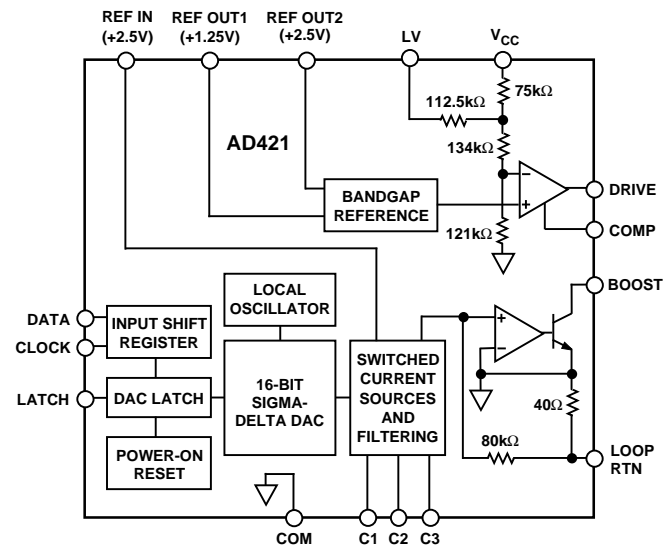

PRODUCT HIGHLIGHTS

1. The AD421 is a single chip, high performance, low cost solution for generating 4–20 mA signals for smart industrial control transmitters.
2. The AD421's regulated supply voltage can be used to power any additional circuits in the transmitter. The regulated output value is pin selectable as either +3 V, +3.3 V or +5 V.
3. The AD421's on-chip references can provide a precision reference voltage to other devices in the system. This reference voltage can be either +1.25 V or +2.5 V.
4. The AD421 is fully compatible with standard HART circuitry or other similar FSK protocols.
5. With the addition of a single discrete transistor, the AD421 can be operated from $V_{CC} + 2\text{ V min}$ to a maximum of the breakdown voltage of the pass transistor.
6. The AD421 converts the digital data to current with 16-bit resolution and monotonicity. Full-scale settling time to $\pm 0.1\%$ typically occurs within 8 ms.
7. The AD421 features a programmable alarm current capability that allows the transmitter to send out of range currents to indicate a transducer fault.

AD421—LOOP-POWERED SPECIFICATIONS (Using DN25D¹ as pass transistor as per Figure 3; REF IN = REF OUT2; T_A = T_{MIN} to T_{MAX} unless otherwise noted)

Parameter	B Versions ²	Units	Conditions/Comments
OUTPUT CHARACTERISTICS			
Current Loop Voltage Compliance ³	V _{CC} + 2 350	V min V max	DN25D Breakdown Voltage
Full-Scale Settling Time	8	ms typ	Settling Time to ±0.1%, C1 = C2 = 10 nF, C3 = 3.3 nF
Output Impedance	25	MΩ typ	
AC Loop Voltage Sensitivity	2	μA/V typ	1200 Hz to 2200 Hz
VOLTAGE REGULATOR			
Output Voltage (V _{CC})			
3 V Mode	2.95/3.05	V min/V max	3 V Nominal. LV Pin Connected to V _{CC}
3.3 V Mode	3.25/3.35	V min/V max	3.3 V Nominal. LV Pin Connected Through 0.01 μF to V _{CC}
5 V Mode	4.95/5.05	V min/V max	5 V Nominal. LV Pin Connected to COM
Externally Available Current	3.25	mA min	Assuming 4 mA Flowing in the Loop
Line Regulation	1	μV/V typ	
Load Regulation	15	μV/mA typ	

AD421—DAC SPECIFICATIONS (V_{CC} = +3 V to +5 V; REF IN = REF OUT2; T_A = T_{MIN} to T_{MAX} unless otherwise noted)

Parameter	B Versions ²	Units	Conditions/Comments
ACCURACY			
Resolution	16	Bits	
Monotonicity	16	Bits min	
Integral Nonlinearity	±0.01	% of FS max	FS = Full-Scale Output Current
Offset (4 mA) @ +25°C ⁴	±0.1	% of FS max	V _{CC} = 5 V
Offset Drift	±25	ppm of FS/°C max	Includes On-Chip Reference Drift
Total Output Error (20 mA) @ +25°C ⁴	±0.2	% of FS max	V _{CC} = 5 V
Total Output Drift	±50	ppm of FS/°C max	Includes On-Chip Reference Drift
V _{CC} Supply Sensitivity	50	nA/mV max	25 nA/mV Typical
VOLTAGE REFERENCE			
REF OUT2			
Output Voltage	2.49/2.51	V min/V max	2.5 V Nominal
Drift	±40	ppm/°C max	20 ppm/°C Typical from -40°C to +25°C and -2.5 ppm/°C Typical from +25°C to +85°C
Externally Available Current	0.5	mA min	
V _{CC} Supply Sensitivity	150	μV/V max	15 μV/V Typical
Output Impedance	3	Ω typ	
Noise (0.1 Hz – 10 Hz)	6	μV (p-p) typ	
REF OUT1			
Output Voltage	1.24/1.26	V min/V max	1.25 V Nominal, 100 kΩ Load to COM ⁵
Drift	±50	ppm/°C max	20 ppm/°C Typical from -40°C to +25°C and 2 ppm/°C Typical from +25°C to +85°C
Externally Available Current	0.5	mA min	
V _{CC} Supply Sensitivity	150	μV/V max	15 μV/V Typical
Output Impedance	3	Ω typ	
Noise (0.1 Hz – 10 Hz)	4	μV (p-p) typ	
REF IN			
Input Resistance	40	kΩ typ	
DIGITAL INPUTS			
V _{IH} (Logic 1)	0.75 × V _{CC}	V min	
V _{IL} (Logic 0)	0.25 × V _{CC}	V max	
I _{IH}	±10	μA max	V _{IN} = V _{CC}
I _{IL}	±10	μA max	V _{IN} = 0 V
Data Coding	Binary		
Data Rate	10	Mbps max	
POWER SUPPLIES			
Operating Range	+2.95 to +5.05	V min to V max	Functional to 7 V
Quiescent Current			
@ V _{CC} = 3 V	650	μA max	475 μA Typical
@ V _{CC} = 5 V	750	μA max	575 μA Typical

NOTES

¹The DN25D is available from Supertex, Inc., 1350 Bordeaux Drive, Sunnyvale, CA 94089.

²Temperature range is -40°C to +85°C.

³The max current loop voltage compliance is determined by the pass transistor breakdown voltage and is 350 V for the DN25D.

⁴With V_{CC} = 3 V, the transfer function shifts negative by typically 0.25%; a 16 kΩ resistor connected between COM and LOOPRTN will approximately compensate for the V_{CC} supply sensitivity in moving from 5 V to 3 V by skewing the gain of the AD421.

⁵100 kΩ resistor only required if this reference is being used in application circuits.

Specifications subject to change without notice.

TIMING CHARACTERISTICS^{1, 2, 3} ($V_{CC} = +3\text{ V to } +5\text{ V}$, $T_A = T_{MIN}$ to T_{MAX} unless otherwise noted)

Parameter	(B Versions)	Units	Conditions/Comments
t_{CK}	100	ns min	Data Clock Period
t_{CL}	50	ns min	Data Clock Low Time
t_{CH}	50	ns min	Data Clock High Time
t_{DW}	30	ns min	Data Stable Width
t_{DS}	30	ns min	Data Setup Time
t_{DH}	0	ns min	Data Hold Time
t_{LD}	50	ns min	Latch Delay Time
t_{LL}	50	ns min	Latch Low Time
t_{LH}	50	ns min	Latch High Time

NOTES

¹Guaranteed by characterization at initial product release, not production tested.

²See Figures 1 and 2.

³All input signals are specified with $t_r = t_f = 5\text{ ns}$ (10% to 90% of V_{CC}) and timed from a voltage level of $(V_{IN} + V_{IL})/2$; t_r and t_f should not exceed $1\text{ }\mu\text{s}$ on any digital input.

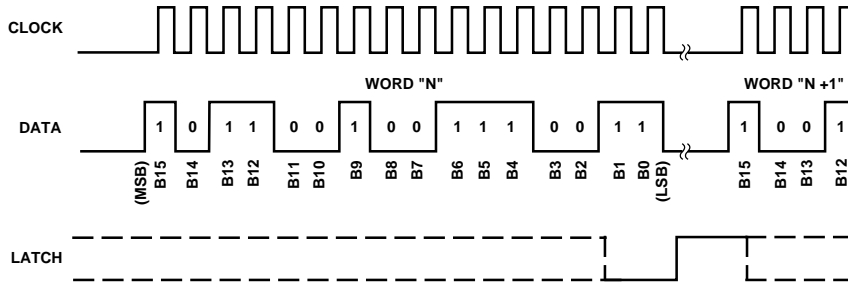

Figure 1. Serial Interface Waveforms (Normal Data Load)

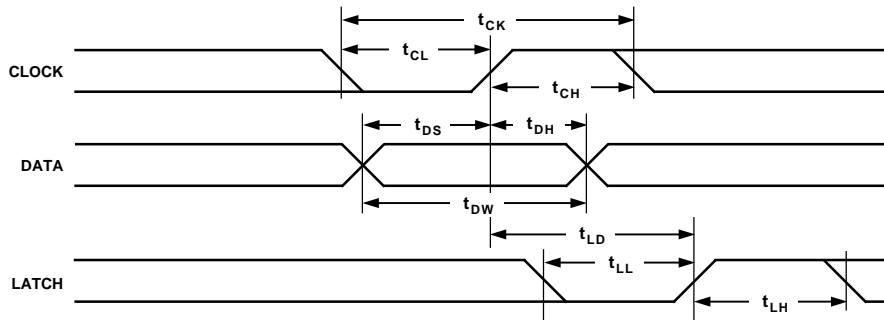

Figure 2. Serial Interface Timing Diagram

AD421

ABSOLUTE MAXIMUM RATINGS*

(T_A = +25°C unless otherwise noted)

DRIVE, BOOST, COMP to COM -0.5 V to V _{CC} + 0.5 V
LOOP RTN to COM -2 V to + 0.5 V
Digital Input Voltage to COM -0.5 V to V _{CC} + 0.5 V
Operating Temperature Range	
Commercial (B Version) -40°C to +85°C
Storage Temperature Range -65°C to +150°C
Junction Temperature +150°C
Plastic DIP Package, Power Dissipation 670 mW
θ _{JA} Thermal Impedance 116°C/W
Lead Temperature (Soldering, 10 sec) 260°C

SOIC Package, Power Dissipation 450 mW
θ _{JA} Thermal Impedance 110°C/W
Lead Temperature, Soldering	
Vapor Phase (60 sec) +215°C
Infrared (15 sec) +220°C
TSSOP Package, Power Dissipation 450 mW
θ _{JA} Thermal Impedance 160°C/W
Lead Temperature, Soldering	
Vapor Phase (60 sec) +215°C
Infrared (15 sec) +220°C

*Stresses above those listed under "Absolute Maximum Ratings" may cause permanent damage to the device. This is a stress rating only and functional operation of the device at these or any other conditions above those listed in the operational sections of this specification is not implied. Exposure to absolute maximum rating conditions for extended periods may affect device reliability.

CAUTION

ESD (electrostatic discharge) sensitive device. Electrostatic charges as high as 4000 V readily accumulate on the human body and test equipment and can discharge without detection. Although these devices feature proprietary ESD protection circuitry, permanent damage may occur on devices subjected to high energy electrostatic discharges. Therefore, proper ESD precautions are recommended to avoid performance degradation or loss of functionality.



PIN CONFIGURATION DIP, TSSOP and SOIC

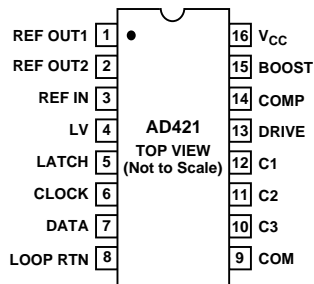

ORDERING GUIDE

Model	Temperature Range	Package Option ¹
AD421BN	-40°C to +85°C	N-16
AD421BR	-40°C to +85°C	R-16
AD421BRRL	-40°C to +85°C	R-16; Reeled SOIC
AD421BRURL	-40°C to +85°C	RU-16; Reeled TSSOP ²
AD421BRURL7	-40°C to +85°C	RU-16; Reeled TSSOP ³
EVAL-AD421-EB	Evaluation Board	

NOTES

¹N = Plastic DIP, R = SOIC, RU = TSSOP.

²Available on 13" reel; min order quantity is 4,000.

³Available on 7" reel; min order quantity is 1,400.

PIN FUNCTION DESCRIPTION

Pin No.	Mnemonic	Function
1	REF OUT1	Reference Output 1. A precision +1.25 V reference is provided at this pin. It is intended as a precision reference source for other devices in the transmitter. REF OUT1 is a buffered output capable of providing up to 0.5 mA to external circuitry.
2	REF OUT2	Reference Output 2. A precision +2.5 V reference is provided at this pin. To operate the AD421 with its own reference, REF OUT2 should be connected to REF IN. It can also be used as a precision reference source for other devices in the transmitter. REF OUT2 is a buffered output capable of providing up to 0.5 mA to external circuitry.
3	REF IN	Voltage Reference Input. The reference voltage for the AD421 is applied to this pin and it sets the span for the AD421. The nominal reference voltage for the AD421 is +2.5 V for correct operation. This can be supplied using an external reference source or by using the part's own REF OUT2 voltage.
4	LV	Regulated Voltage Control Input. The LV input controls the loop gain of the servo amplifier to set V_{CC} . With LV connected to COM, the regulator voltage is set to 5 V nominal. If the LV input is connected through 0.01 μF to V_{CC} , the regulated voltage is nominally 3.3 V. With LV connected to V_{CC} the regulated voltage, V_{CC} , is 3 V nominal.
5	LATCH	DAC Latch Input. Logic Input. A rising edge of the LATCH signal loads the data from the serial input shift register to the DAC latch and hence updates the output of the DAC.
6	CLOCK	Data Clock Input. Data on the DATA input is clocked into the shift register on the rising edge of this CLOCK input. The period of this clock equals the input serial data bit rate. This serial clock rate can be up to 10 MHz. If 16 clock cycles are provided between LATCH pulses then the data on the DATA input is accepted as normal 4–20 mA data. If more than 16 clock cycles are provided between LATCH pulses, the data is assumed to be alarm current data (see <i>Digital Interface</i> section).
7	DATA	Data Input. The data to be loaded to the AD421 input shift register is applied to this input. Data should be valid on the rising edge of the CLOCK input.
8	LOOP RTN	Loop Return Output. LOOP RTN is the return path for current flowing in the current loop.
9	COM	Common. This is the reference potential for the AD421 analog and digital inputs and outputs and for the voltage regulator output.
10	C3	Filtering Capacitor. A low dielectric absorption capacitor ceramic capacitor should be connected between this pin and COM for internal filtering of the switched current sources.
11	C2	Filtering Capacitor. See C3 description.
12	C1	Filtering Capacitor. See C3 description.
13	DRIVE	Output from the Voltage Regulator Loop. The DRIVE signal controls the external pass transistor to establish and maintain the correct V_{CC} level programmed by the LV inputs while providing the necessary bias as the loop current is programmed from 4 mA to 20 mA.
14	COMP	Compensation Capacitor Input. A capacitor connected between COMP and DRIVE is required to stabilize the feedback loop formed with the regulator op amp and the external pass transistor.
15	BOOST	This open collector pin sinks the necessary current from the loop so that the current flowing into BOOST plus the current flowing into COM is equal to the programmed loop current.
16	V_{CC}	Power Supply. V_{CC} is the power supply input of the AD421 and it also provides the voltage regulator output, driven by the external pass transistor. It is used both to bias the AD421 itself and to provide power for the rest of the smart transmitter circuitry. The LV input determines the regulated voltage output to be either 3 V, 3.3 V or 5 V nominal. Alternatively, a separate power supply can be connected to this pin to power the AD421.

AD421

CIRCUIT DESCRIPTION

The AD421 is designed for use in loop-powered 4–20 mA smart transmitter applications. A smart transmitter, as a remote instrument, controls its current output signal on the same pair of wires from which it receives its power. The AD421 essentially provides three primary functions in the smart transmitter. These functions are a DAC function for converting the microprocessor/microcontroller's digital data to analog format, a current amplifier which sets the current flowing in the loop and a voltage regulator to provide a stable operating voltage from the loop supply. The part also contains a high speed serial interface, two buffered output references and a clock oscillator circuit. The different sections of the AD421 are discussed in more detail below.

Voltage Regulator

The voltage regulator consists of an op amp, bandgap reference and an external depletion mode FET pass transistor. This circuit is required to regulate the loop voltage that powers the AD421 itself and the rest of the transmitter circuitry. Figure 3 shows the voltage regulator section of the AD421 plus the associated external circuitry for a V_{CC} of 3.3 V.

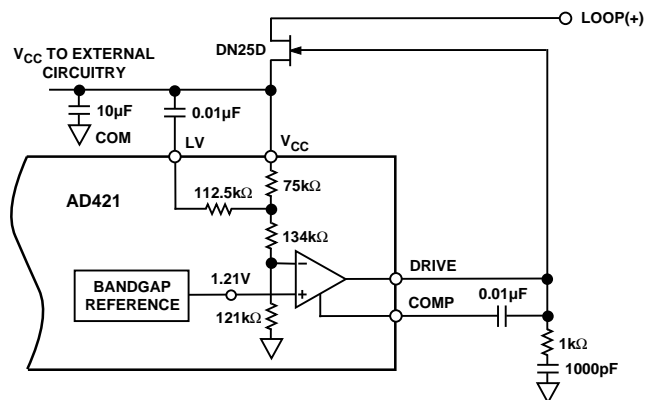

Figure 3. AD421 Voltage Regulator Circuit to Provide $V_{CC} = 3.3$ V

The signal on the LV pin selects the voltage to which V_{CC} regulates by changing the gain of the resistor divider between the op amp inverting input and the V_{CC} pin. As the LV pin varies between COM and V_{CC} , the voltage from the regulator loop varies between 3 V and 5 V nominal. With LV connected to COM, the regulated voltage is 5 V; with LV connected through a $0.01 \mu\text{F}$ capacitor to V_{CC} , the regulated voltage is 3.3 V while if LV is connected to V_{CC} , the regulated voltage is 3 V.

The range of loop voltages that can be used by the configuration shown in Figure 3 is determined by the FET breakdown and saturation voltages. The external FET parameters such as V_{gs} (off), I_{DSS} and transconductance must be chosen so that the op amp output on the DRIVE pin can control the FET operating point while swinging in the range from V_{CC} to COM.

The main characteristics for selecting the FET pass transistor are as follows:

Table I. FET Characteristics

FET Type	N-Channel Depletion Mode
I_{DSS}	24 mA min
BV_{DS}	$(V_{LOOP} - V_{CC})$ min
$V_{PINCHOFF}$	V_{CC} max
Power Dissipation	$24 \text{ mA} \times (V_{LOOP} - V_{CC})$ min

where V_{CC} is the operating voltage of the AD421 and V_{LOOP} is the loop voltage.

The DN25D FET transistor meets all the above requirements for the FET. Other suitable transistors include ND2020L and ND2410L, both from Siliconix.

There are a number of external components required to compensate the regulator loop and ensure stable operation. The capacitor from the V_{CC} pin to the COM pin is required to stabilize the regulator loop. This capacitor should be kept in the $4.7 \mu\text{F}$ to $10 \mu\text{F}$ range as it has to suppress glitches from the AD421 as well as power glitches on the ADC and microprocessor which may be incorporated as part of a smart transmitter. In intrinsically safe applications it is required that the capacitance be kept as low as possible for use in hazardous environments. The capacitance on the V_{CC} cannot be reduced below $4.7 \mu\text{F}$ as the regulator stability will be compromised.

To provide additional compensation for the regulator loop, a compensation capacitor of $0.01 \mu\text{F}$ should be connected between the COMP and DRIVE and an external circuit of a $1 \text{ k}\Omega$ resistor and a 1000 pF capacitor in series should be connected between DRIVE and COM to stabilize this feedback loop formed with the regulator op amp and the external pass transistor.

DAC Section

The AD421 contains a 16-bit sigma-delta DAC to convert the digital information loaded to the input latch into a current. The sigma-delta architecture is particularly useful for the relatively low bandwidth requirements of the industrial control environment because of its inherent monotonicity at high resolution. The AD421 guarantees monotonicity to the 16-bit level.

The sigma-delta DAC consists of a second order modulator followed by a continuous time filter. The single bit stream from the modulator controls a switched current source. This current source is then filtered by three resistor-capacitor filter sections. The resistors for each of the filter sections are on-chip while the capacitors are external on the C1–C3 pins. To meet the specified full-scale settling on the part, low dielectric absorption capacitors (NPO) are required. Suitable values for these capacitors are $C1 = 0.01 \mu\text{F}$, $C2 = 0.01 \mu\text{F}$, and $C3 = 0.0033 \mu\text{F}$.

Current Amplifier

The DAC output current drives the second section, an operation amplifier and NPN transistor which acts as a current amplifier to set the current flowing through the LOOP RTN pin. Figure 4 shows the current amplifier section of the AD421. An $80 \text{ k}\Omega$ resistor connected between the DAC output and loop return is used as a sampling resistor to determine current. The base drive to the NPN transistor servos the voltage across the 40Ω resistor to equal the voltage across the $80 \text{ k}\Omega$ resistor.

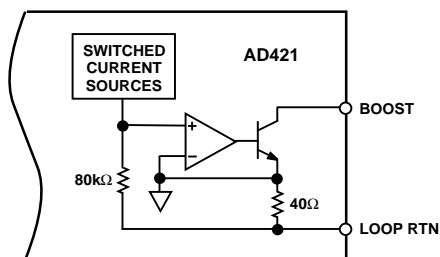

Figure 4. Current Amplifier

The BOOST pin is normally tied to the V_{CC} pin. As the DAC input code varies from all zeroes to full scale, the output current from the NPN transistor and thus the total loop current varies from 4 mA to 20 mA. With BOOST and V_{CC} tied together, the external FET (DN25D) has to supply the full range of loop current (4 mA to 20 mA).

Digital Interface

The digital interface on the AD421 consists of just three wires: DATA, CLOCK and LATCH. The interface connects directly to the serial ports of commonly-used microcontrollers without the need for any external glue logic. Data is loaded MSB first into an input shift register on the rising edge of the CLOCK signal and is transferred to the DAC latch on the rising edge of the LATCH signal. The timing diagrams for the serial interface are shown in Figure 1 and Figure 2.

The data to be loaded to the AD421's input shift register takes two forms; normal 4–20 mA data or alarm current data. The first form is where the AD421 operates over its normal 4 mA to 20 mA output range with 16 bits of resolution between these endpoints. The second form allows the user to program a current value outside this range as an indication from the transmitter that there is a problem with the transducer. The AD421 counts the number of clock pulses which it receives between LATCH signals as a means of determining whether the data clocked in is 4–20 mA data or alarm current data.

If there are 16 rising clock edges between successive LATCH pulses, then the data being loaded to the input shift register is assumed to be normal 4–20 mA data. On the rising edge of the LATCH signal, the input shift register data is transferred to the DAC latch in a 16-bit parallel transfer. In this case, the 16 bits of data in the DAC latch program the output current between 4 mA for all 0s and 20 mA for all 1s (see Table II). Data transferred to the AD421 should be MSB first.

If there are more than 16 clock pulses between successive LATCH pulses, then the data being loaded to the input shift register is assumed to be alarm current data. In this case, the AD421 accepts 17 bits of data into its shift register. For situations where there are more than 17 clocks in the serial write operation (for example, 24 clocks in a 3×8 -bit transfer from the serial port of a microcontroller) the AD421 simply accepts the last 17 bits of the serial write operation. Data transferred in this serial write operation is LSB last (i.e., the MSB is loaded on the 17th rising clock edge prior to the LATCH pulse). On the rising edge of the LATCH signal, the input shift register data is transferred to the DAC latch in a 17-bit parallel transfer. In this case, the 17 bits of data in the DAC latch program the output current between 0 mA for all 0s and 32 mA for all 1s (see Table III). However, in practice the AD421 cannot reliably produce a current less than 3.5 mA or more than 24 mA.

Reference Section

The AD421 contains an on-chip 1.21 V bandgap reference which is used as part of the voltage regulator loop. A bandgap reference is also used to generate two reference voltages which are available for use external to the AD421. Figure 5 shows the reference section of the AD421. The REF OUT1 pin provides a buffered +1.25 V reference voltage which can supply up to 0.5 mA of external current. The REF OUT2 pin provides a +2.5 V reference voltage which is also capable of providing 0.5 mA of external current. To use the AD421 with its own reference, simply connect the REF OUT2 pin to the REF IN pin of the device. Alternatively, the part can be used with an external reference by connecting the external reference between REF IN and COM.

When REF OUT1 and REF OUT2 are used in application circuits, external 4.7 μ F capacitors are required on the reference pins to provide compensation and ensure stable operation of the references. These capacitors can be omitted if the internal references are not required.

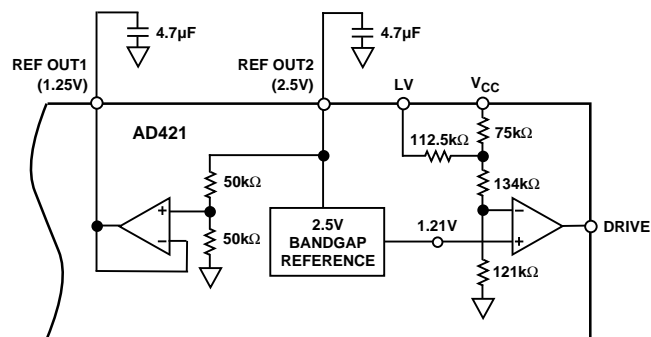

Figure 5. Reference Section

REF OUT2 is sensed internally, and if more than 0.5 mA is drawn externally from this reference, the chip goes into a power on reset state. In this state the sigma-delta DAC is disabled, the internal oscillator is stopped and the input data latch is cleared.

REF OUT1 has limited current sinking capability. If REF OUT1 is required to sink current, a resistive load of 100 k Ω to COM should be added in addition to the 4.7 μ F capacitor.

USING THE AD421

The AD421 can be programmed for normal 4–20 mA operation or for alarm current operation. For normal operation, the coding is 16-bit straight (natural) binary over an output current range of 4 mA to 20 mA. For alarm current operation, the coding is also straight binary but with 17 bits of resolution over twice the span, 0 mA to 32 mA, although the part should not be programmed outside the range of 3.5 mA to 24 mA. To determine whether data written to the part is normal 4–20 mA data or alarm current data, the number of clock pulses between two successive LATCH pulses are counted.

4–20 mA Coding

Table II shows the ideal input-code-to-output-current relationship for normal operation of the AD421. The output current values shown assume a REF IN voltage of +2.5 V. With a REF IN of +2.5 V, 1 LSB = $16 \text{ mA}/65,536 = 244 \text{ nA}$. Figure 6 shows a timing diagram for programming the AD421 for normal 4–20 mA operation, the AD421 outputting a current of 11.147 mA. With 16 clock pulses between consecutive latch signals data written is for normal 4–20 mA operation.

AD421

Table II. Ideal Input/Output Code Table for 4–20 mA Operation

Code	Output Current
0000 0000 0000 0000	4 mA
0000 0000 0000 0001	4.000244 mA
0000 0000 0000 0010	4.000488 mA
0100 0000 0000 0000	8 mA
1000 0000 0000 0000	12 mA
1100 0000 0000 0000	16 mA
1111 1111 1111 1101	19.999268 mA
1111 1111 1111 1110	19.999512 mA
1111 1111 1111 1111	19.999756 mA

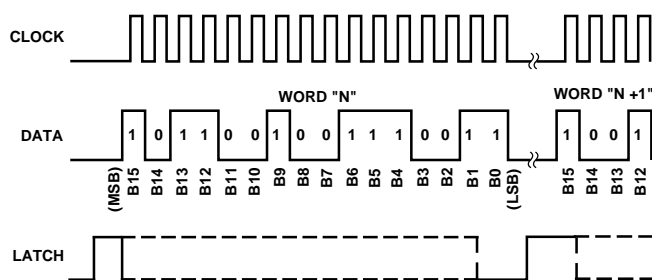

Figure 6. Write Cycle for 4–20 mA Operation

Alarm Current Coding

Table III shows the ideal input-code-to-output-current relationship for alarm current programming of the AD421. In this case, the equivalent span is 0 mA to 32 mA but a reliable operating span is 3.5 mA to 24 mA. The part may give an indeterminate output for code values outside the range given in the table. As a result, the user is advised to restrict the code programmed to the part in alarm current mode to within the range shown in Table III. Figure 7 shows a timing diagram for loading an alarm current of 3.75 mA to the AD421 with an 8-bit microcontroller using three 8-bit writes.

The output current values shown assume a REF IN voltage of +2.5 V. With a REF IN of +2.5 V, an ideal 1 LSB = 32 mA/131,072 = 244 nA.

Table III. Ideal Input/Output Code Table for Alarm Current Operation

Code	Output Current
0 0011 1000 0000 0000	3.5 mA
0 0011 1100 0000 0000	3.75 mA
0 0100 0000 0000 0000	4 mA
0 1000 0000 0000 0000	8 mA
1 0000 0000 0000 0000	16 mA
1 0100 0000 0000 0000	20 mA
1 0110 0000 0000 0000	22 mA
1 1000 0000 0000 0000	24 mA

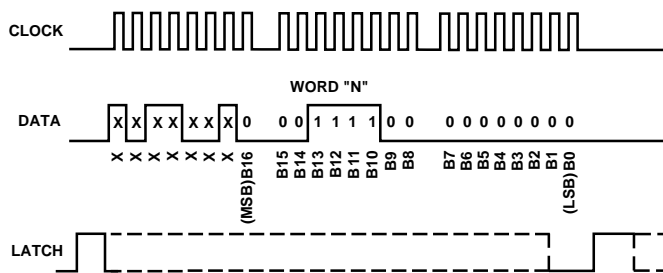
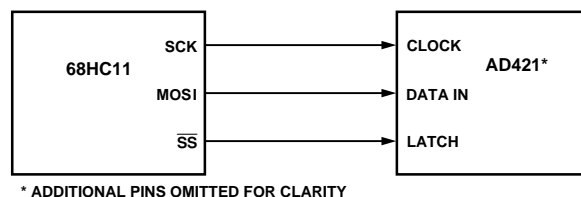

Figure 7. Write Cycle for Programming Alarm Current Data

MICROPROCESSOR INTERFACING

AD421 – MC68HC11 (SPI BUS) INTERFACE

Figure 8 shows a typical interface between the AD421 and the Motorola MC68HC11 SPI (Serial Peripheral Interface) bus. The SCK, MOSI and SS pins of the 68HC11 are respectively connected to the CLOCK, DATA IN and LATCH pins of the AD421.



* ADDITIONAL PINS OMITTED FOR CLARITY

Figure 8. AD421 to 68HC11 Interface

A typical routine such as the one shown below begins by initializing the state of the various SPI data and control registers.

```

INIT   LDAA  #$2F      ;SS = 1; SCK = 0; MOSI = 1
       STAA  PORTD    ;SEND TO SPI OUTPUTS
       LDAA  #$38      ;SS, SCK, MOSI = OUTPUTS
       STAA  DDRD     ;SEND DATA DIRECTION INFO
       LDAA  #$50      ;DABL INTRPTS, SPI IS MASTER & ON
       STAA  SPCR     ;CPOL = 0, CPHA = 0, 1MHZ BAUDRATE
NEXTPT LDAA  MSBY     ;LOAD ACCUM W/UPPER 8 BITS
       BSR  SENDAT   ;JUMP TO DAC OUTPUT ROUTINE
       JMP  NEXTPT   ;INFINITE LOOP
SENDAT LDY  #$1000    ;POINT AT ON-CHIP REGISTERS
       BCLR $08,Y,$20 ;DRIVE SS (LATCH) LOW
       STAA SPDR     ;SEND MS-BYTE TO SPI DATA REG
WAIT1  LDAA  SPSR     ;CHECK STATUS OF SPIE
       BPL  WAIT1    ;POLL FOR END OF X-MISSION
       LDAA  LSBY     ;GET LOW 8 BITS FROM MEMORY
       STAA  SPDR     ;SEND LS-BYTE TO SPI DATA REG
WAIT2  LDAA  SPSR     ;CHECK STATUS OF SPIE
       BPL  WAIT2;   ;POLL FOR END OF X-MISSION
       BSET $08,Y,$20 ;DRIVE SS HIGH TO LATCH DATA
       RTS
    
```

The SPI data port is configured to process data in 8-bit bytes. The most significant data byte (MSBY) is retrieved from memory and processed by the SENDAT routine. The SS pin is driven low by indexing into the PORTD data register and clear Bit 5. The MSBY is then sent to the SPI data register where it is

automatically transferred to the AD421 internal shift register. The HC11 generates the requisite eight clock pulses with data valid on the rising edges. After the MSBY is transmitted, the least significant byte (LSBY) is loaded from memory and transmitted in a similar fashion. To complete the transfer, the LATCH pin is driven high when loading the complete 16-bit word into the AD421.

AD421 TO MICROWIRE INTERFACE

The flexible serial interface of the AD421 is also compatible with the National Semiconductor MICROWIRE interface. The MICROWIRE interface is used in microcontrollers such as the COP400 and COP800 series of processors. A generic interface to use the MICROWIRE interface is shown in Figure 9. The G1, SK, and SO pins of the MICROWIRE interface respectively connected to the LATCH, CLOCK, and DATA IN pins of the AD421.

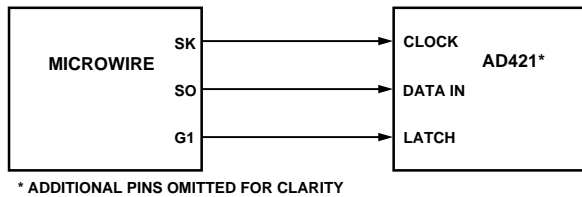

Figure 9. AD421 to MICROWIRE Interface

Opto-Isolated Interface

The AD421 has a versatile serial 3-wire serial interface making it ideal for minimizing the number of control lines required for isolation of the digital system from the control loop. In intrinsically safe applications or due to noise, safety requirements, or distance, it may be necessary to isolate the AD421 from the controller. This can easily be achieved by using opto-isolators. Figure 10 shows an opto-isolated interface to the AD421 where CLOCK, DATAIN and LATCH are driven from opto-couplers. Be aware of signal inversion across the opto-couplers.

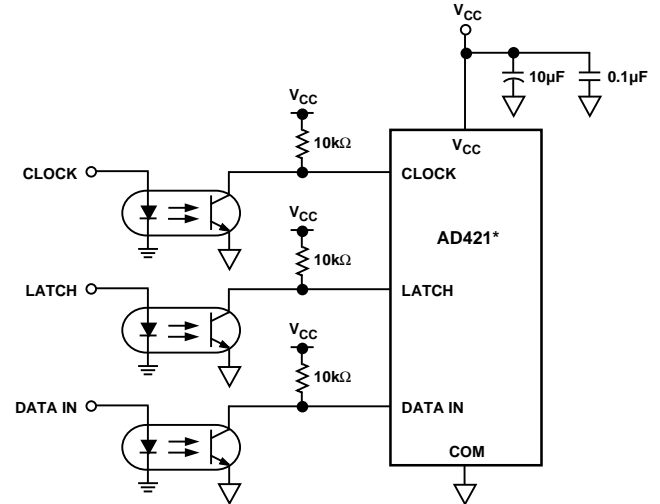

Figure 10. Opto-Isolated Interface

APPLICATIONS SECTION

Basic Operating Configuration

Figure 11 shows the basic connection diagram for the AD421 operating at 5 V. This circuit shows the minimum of external components to operate the AD421. In the diagram, the AD421's regulator loop in conjunction with the DN25D pass transistor provides the V_{CC} voltage for the AD421 itself and for other devices in the trans-mitter. The V_{CC} pin should be well decoupled with a 10 μ F capacitor to ensure regulator stability and to absorb power glitches on the V_{CC} line of the AD421 and other devices in the system. If the AD421 is operated with $V_{CC} = 3$ V, the transfer function shifts negative. To correct for this a 16 k Ω resistor connected between COM and LOOPRTN will approximately compensate for the V_{CC} supply sensitivity in moving from 5 V to 3 V by adjusting the gain of the AD421.

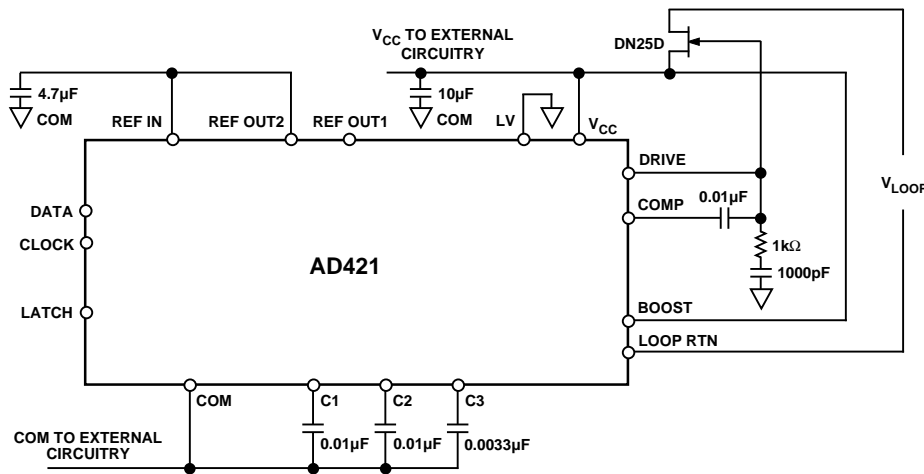

Figure 11. Basic Connection Diagram

AD421

A capacitor of 0.01 μF connected between COMP and DRIVE is required to stabilize the feedback loop formed with the regulator op amp and the external pass transistor. An external snubber circuit of 1 k Ω and 1000 pF is required between the DRIVE pin and COM and a 0.1 μF cap between COMP and DRIVE to stabilize the feedback loop formed by the regulator op amp and the external pass transistor.

The internal 2.5 V reference on the AD421 is used as the reference for the AD421 and this has to be decoupled with a 4.7 μF capacitor for compensation and stability purposes. The sigma-delta DAC on the part consists of a second order modulator followed by a continuous time filter. The resistors for each of the filter sections are on-chip while the capacitors are external on the C1 to C3 pins. To meet the specified full-scale settling on the part, low dielectric absorption capacitors (NPO) are required. Suitable values for these capacitors are C1 = C2 = 0.01 μF , and C3 = 0.0033 μF .

The digital interface on the AD421 consists of just three wires: DATA, CLOCK and LATCH. The interface connects directly to the serial ports of commonly-used microcontrollers without the need for any external glue logic. Data is loaded into an input shift register on the rising edge of the CLOCK signal and is transferred to the DAC latch on the rising edge of the LATCH signal.

Reduce Power Load on External FET

Figure 12 shows a circuit where an external NPN transistor is added to reduce the power loading on the FET. The FET will supply the V_{CC} and an external high voltage NPN bipolar transistor can carry the BOOST current. The BOOST pin sinks the necessary current from the loop so that the current flowing into BOOST plus the current flowing into COM is equal to the programmed loop current. The external NPN transistor reduces the external power load that the FET has to carry to less than 750 μA if no other components share the V_{CC} line and to less than 4 mA in applications that share the same V_{CC} line as the AD421.

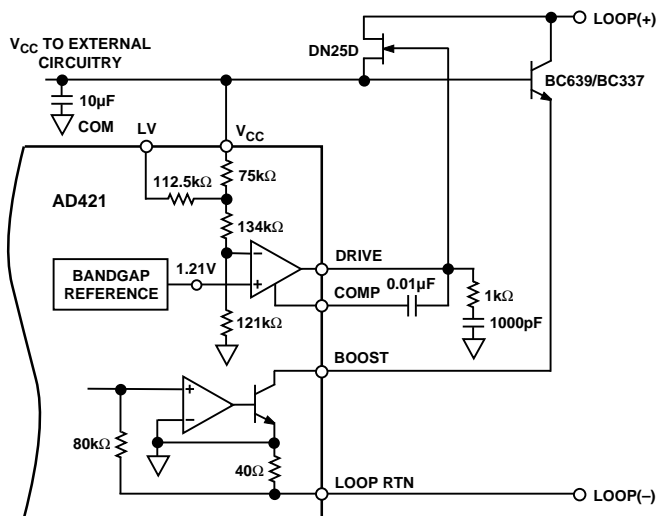

Figure 12. External NPN Transistor Reduces Power Load on FET

Smart Transmitter

The AD421 is intended for use in 4 to 20 mA smart transmitters. A smart transmitter is a system that incorporates a microprocessor system which is used for linearization and communication. Figure 13 shows a block diagram of a typical smart transmitter. In this example, the transmitter does not have any digital communication capabilities.

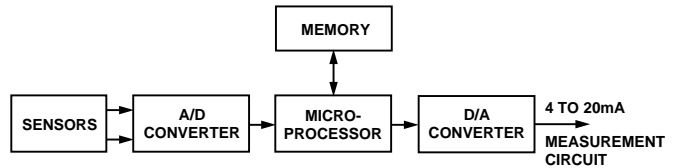

Figure 13. Typical Smart Transmitter

Figure 14 shows a typical smart transmitter application circuit using the AD421.

The sensor voltage to be measured at the transmitter is converted using a high resolution sigma-delta converter such as the AD7714 or AD7715. These devices have an on-board PGA which can provide gains on the analog front end from 1 to 128. This allows for an analog input range as low as 10 mV which allows the transducer to be connected directly to the ADC. The AD7714/AD7715 have digital calibration techniques which are used to eliminate gain and offset errors. In addition, background calibration techniques are provided whereby the part continually calibrates itself and the user does not have to worry about issuing periodic calibration commands to remove effects of time and temperature drift.

In normal operation the microprocessor reads the data from the AD7714/AD7715. After the data is processed by the microcontroller, the data is transferred from the serial port of the processor to the AD421 for transmission over the 4 to 20 mA loop back to the control center.

The AD421 regulates the loop voltage to create power for the rest of the transmitter circuitry. In Figure 14, the derived V_{CC} voltage is 3.3 V which is achieved by connecting the LV pin to V_{CC} through 0.01 μF . REF OUT2 provides the reference voltage for the AD421 itself while REF OUT1 provides the reference voltage for the AD7714/AD7715.

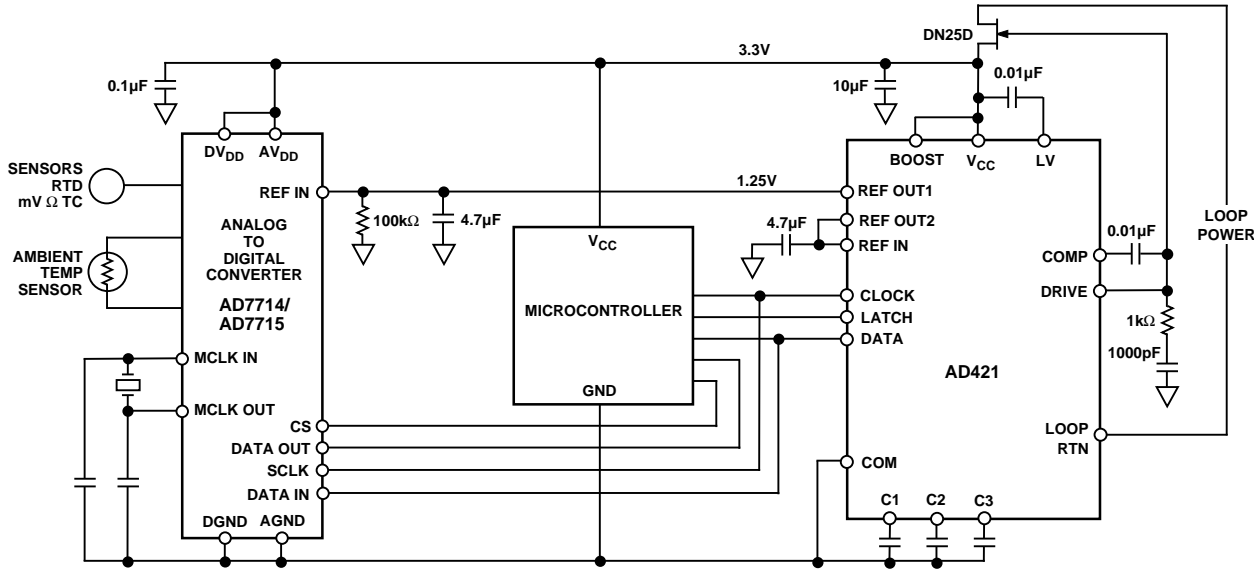

Figure 14. AD421 in Smart Transmitter Application

HART Interfacing

The HART protocol uses a frequency shift (FSK) keying technique based on the *Bell 202 Communication Standard* which is one of several standards used to transmit digital signals over the telephone lines. This technique is used to superimpose digital communication on to the 4 to 20 mA current loop connecting the central system to the transmitter in the field. Two different frequencies, 1200 Hz and 2200 Hz, are used to represent binary 1 and 0 respectively, as shown in Figure 15. These sine wave tones are superimposed on the dc signal at a low level with the average value of the sine wave signal being zero. This allows simultaneous analog and digital communications. Additionally, no dc component is added to the existing 4 to 20 mA signal regardless of the digital data being sent over the line. Consequently, existing analog instruments continue to work in systems that implement HART as the low-pass filtering usually present effectively removes the digital signal. A single pole 10 Hz low-pass filter effectively reduces the communication signal to a ripple of about ±0.01% of the full-scale signal. The HART protocol specifies that master devices like a host control system or a hand held terminal transmit a voltage signal whereas a slave or field device transmits a current signal. The current signal is converted into a corresponding voltage by the loop load resistor.

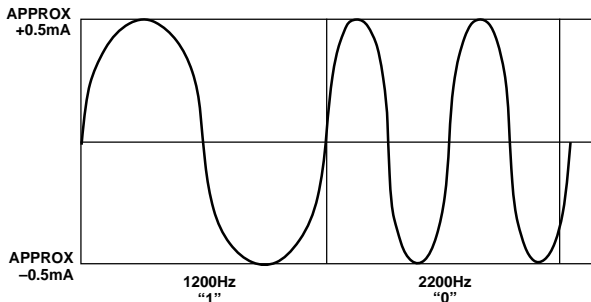

Figure 15. HART Transmission of Digital Signals

Figure 16 shows a block diagram of a smart and intelligent transmitter. An intelligent transmitter is a transmitter in which the functions of the microprocessor are shared between deriving the primary measurement signal, storing information regarding the transmitter itself, its application data and its location and also managing a communication system which enables two way communication to be superimposed on the same circuit that carries the measurement signal. A smart transmitter incorporating the HART protocol is an example of a smart intelligent transmitter.

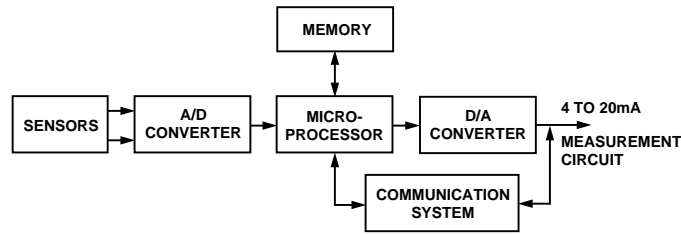

Figure 16. Smart and Intelligent Transmitter

Figure 17 shows an example of the AD421 in a HART transmitter application. Most of the circuit is as outlined in the smart transmitter as shown in Figure 14. The HART data transmitted on the loop is received by the transmitter using a bandpass filter and modem and the HART data is transferred to the microcontroller's UART or asynchronous serial port. HART data to be transmitted on the loop is sent from the microcontroller's UART or asynchronous serial port to the modem. It is then waveshaped before being coupled onto the AD421's output at the C3 pin. The value of the coupling capacitor C_c is determined by the waveshaper output and the C3 capacitor of the AD421. The blocks containing the Bell 202 Modem, waveshaper and bandpass filter come in a complete solution with the 20C15 from Symbios Logic, Inc., or HT2012 from SMAR Research Corp.

AD421

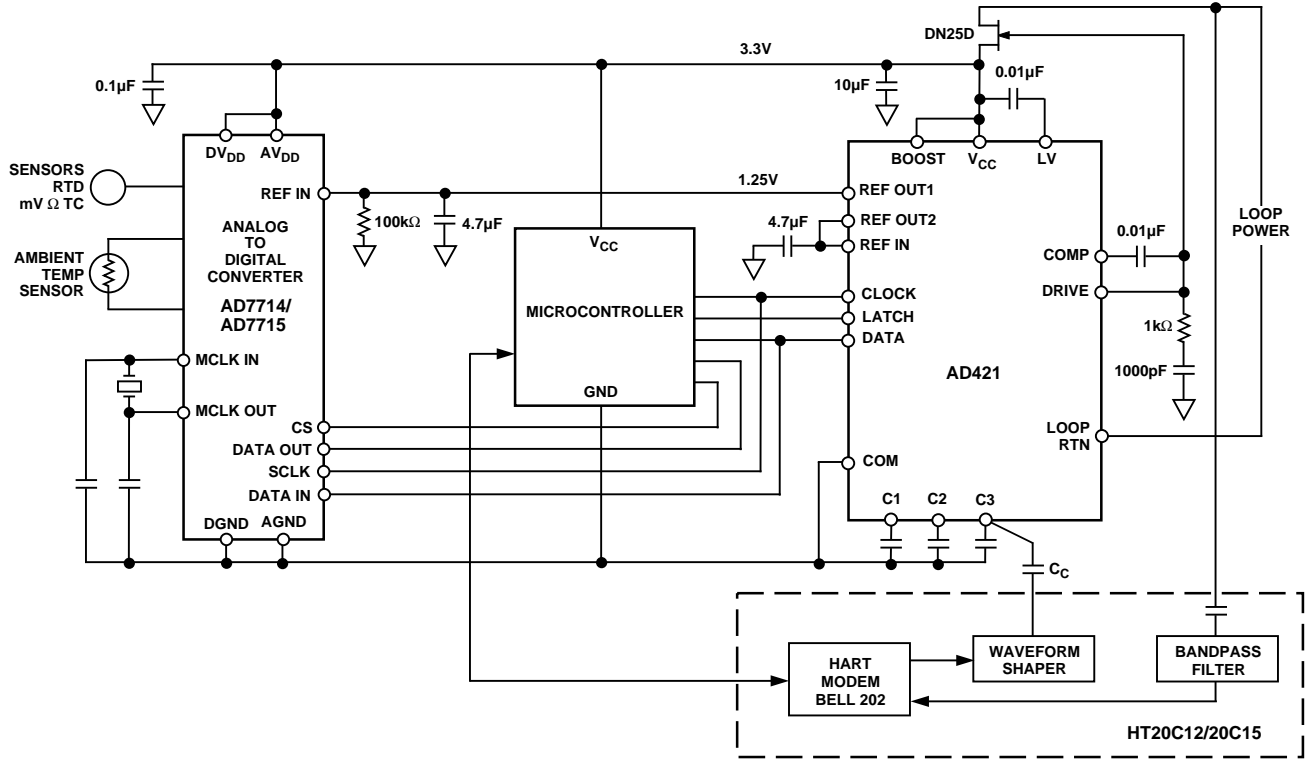

Figure 17. AD421 in HART Transmitter Application

Current Source

Figure 18 shows an application circuit for the AD421 being used as a current source. The current programmed to the AD421 (4 to 20 mA) will develop a voltage across R1. This same voltage due to negative feedback will be generated across

R2. The ratio of R1 to R2 determines the current that flows in the load resistor R_L . $I_L = [1 + R1/R2] \times I_{PROG}$, where I_L is the current that flows in the load resistor R_L and I_{PROG} is the current programmed to the AD421. R1 and R2 are external to the AD421 and will need to be matched resistors to obtain a highly accurate current source.

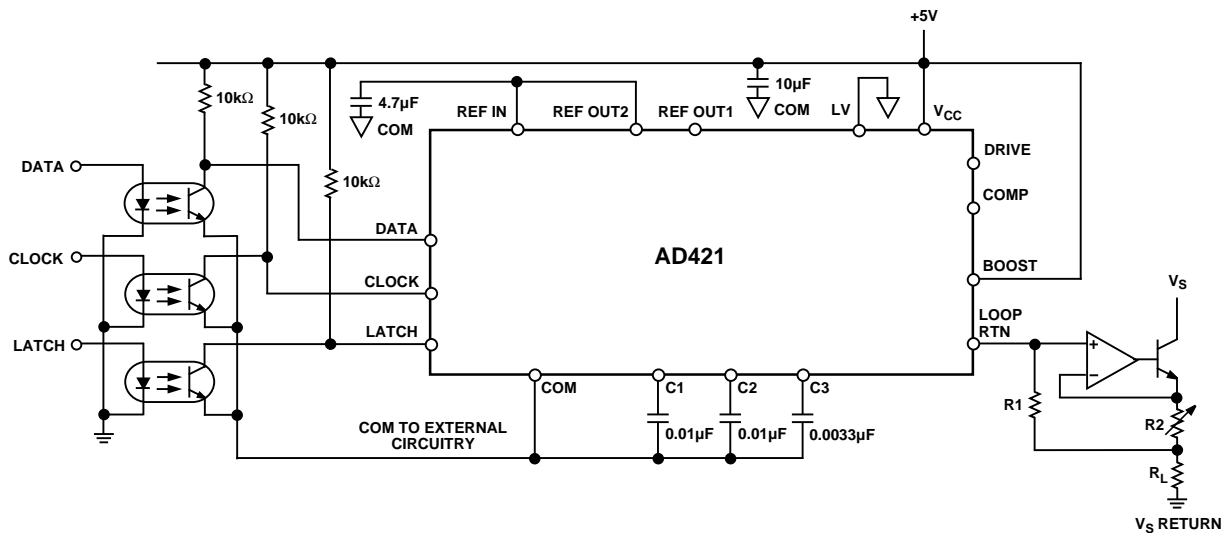

Figure 18. AD421 in Programmable Current Source/Sink

Battery Backup

Figure 19 shows an application circuit for the AD421 where the micro and memory sections of the circuitry are protected against losing data if the loop is broken. The backup circuit switches from V_{CC} to battery voltage without a glitch when V_{CC} power is lost. The IRFF9113 acts as a current source during normal operation and provides a constant charging current to the supercap or Nicad. The loss of V_{CC} drops the IRFF9113's gate voltage to zero volts, which allows the battery or supercaps current to flow through the MOSFET's channel and integral body diode to provide power for the micro and memory sections. To calibrate this circuit, connect an ammeter in series with the battery or supercap. Then with V_{CC} and the load present adjust the 100 k Ω potentiometer for the battery charging current recommended by the battery or supercap manufacturer.

Nonrechargeable batteries should not be used in this application due to danger of explosion.

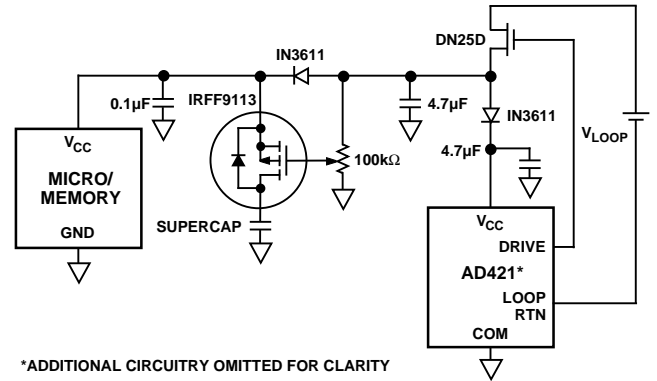

Figure 19. Battery Backup Circuit

AD421

INDEX	
FEATURES	1
GENERAL DESCRIPTION	1
PRODUCT HIGHLIGHTS	1
AD421-LOOP-POWERED SPECIFICATIONS	2
AD421-DAC SPECIFICATIONS	2
TIMING CHARACTERISTICS	3
ABSOLUTE MAXIMUM RATINGS	4
PIN CONFIGURATION	4
PIN FUNCTION DESCRIPTION	5
CIRCUIT DESCRIPTION	6
Voltage Regulator	6
FET Characteristics	6
DAC Section	6
Current Amplifier	6
Digital Interface	7
Reference Section	7
USING THE AD421	7
4-20 mA CODING	7
Alarm Current Coding	8
MICROPROCESSOR INTERFACING	8
APPLICATIONS SECTION	9
Basic Operating Configuration	9
Reduce Power Loading on External FET	10
Smart Transmitter	10
HART Interfacing	11
Current Source	12
Battery Backup	13
MECHANICAL INFORMATION	15

OUTLINE DIMENSIONS

Dimensions shown in inches and (mm).

16-Lead Plastic DIP
(N-16)

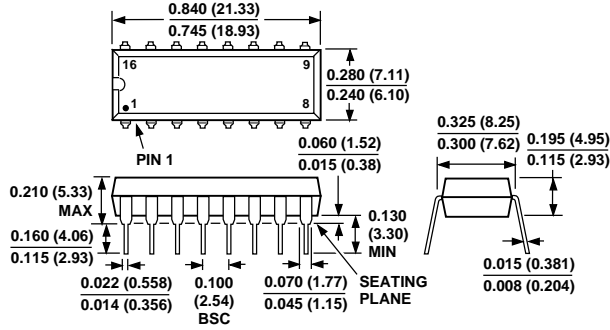

16-Lead (Wide Body) Small Outline Package
(R-16)

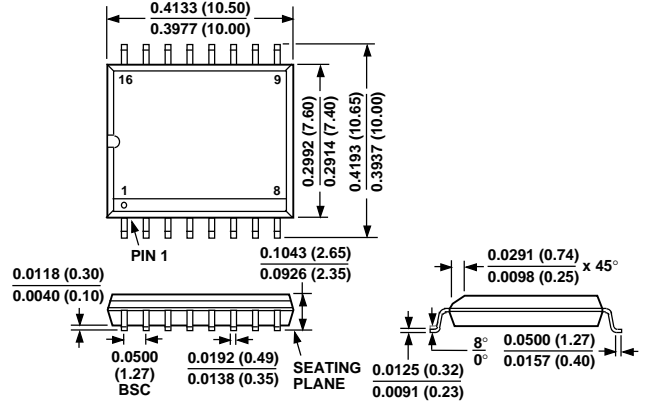

16-Lead Thin Shrink Small Outline Package (TSSOP)
(RU-16)

