

ASSP

Piezoelectric VCO (6 MHz to 30 MHz)

M2 Series (F150)

■ DESCRIPTION

The M2 series (F150) of VCO (Voltage Controlled Oscillator) apply to the frequency range 6 MHz to 30 MHz. These VCOs have a high stability and wide controllable frequency ranges using a LiTaO₃ piezoelectric single crystal with high electromechanical coupling coefficient. Output level applies to CMOS type for digital interface.

■ FEATURES

- Wide frequency controllable range (Over than ± 2000 ppm)
- High carrier noise ratio
- Excellent temperature stability
- CMOS output level
- Compact package (8 mm \times 11 mm \times 2.6 mm)
- Surface mountable package (SMD)

■ PACKAGE

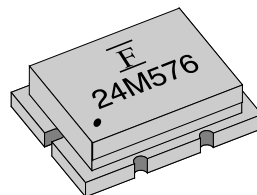

M2 Series (F150)

■ PIN ASSIGNMENT

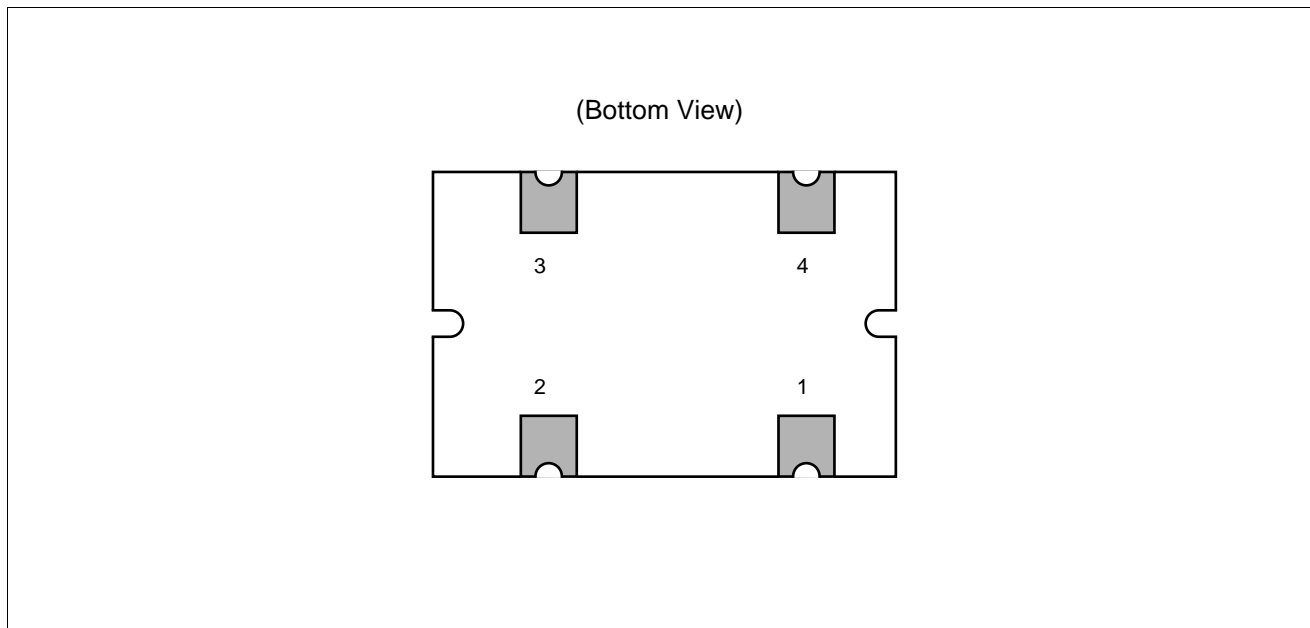

■ PIN DESCRIPTIONS

Pin No.	Symbol	Descriptions
1	V_{IN}	INPUT (Control voltage)
2	GND	GROUND
3	V_{CC}	V_{CC} (Supply voltage)
4	V_{OUT}	OUTPUT

■ ABSOLUTE MAXIMUM RATINGS

Parameter	Symbol	Rating		Unit
		Min.	Max.	
Supply voltage	V_{CC}	-0.5	+7.0	V
Control voltage	V_{IN}	-0.5	+7.0	V
Output voltage	V_{OUT}	-0.5	$V_{CC} + 0.5$	V
Output current	I_{OUT}	-25	+25	mA
Operating temperature	T_a	-10	+70	°C
Storage temperature	T_{stg}	-40	+100	°C

WARNING: Piezoelectric devices can be permanently damaged by application of stress (voltage, current, temperature, etc.) in excess of absolute maximum ratings. Do not exceed these ratings.

■ RECOMMENDED OPERATING CONDITIONS

Parameter	Symbol	Value		Unit
		Min.	Max.	
Supply voltage	V_{CC}	+4.75	+5.25	V
Control voltage	V_{IN}	0	+5.0	V
Operating temperature	T_a	-10	+70	°C

WARNING: The recommended operating conditions are required in order to ensure the normal operation of the piezoelectric device. All of the device's electrical characteristics are warranted when the device is operated within these ranges.

Always use semiconductor devices within their recommended operating condition ranges. Operation outside these ranges may adversely affect reliability and could result in device failure.

No warranty is made with respect to uses, operating conditions, or combinations not represented on the data sheet. Users considering application outside the listed conditions are advised to contact their FUJITSU representatives beforehand.

■ STANDARD FREQUENCIES

Nominal frequency	Part number	Application
13.500 MHz	FAR-M2CC-13M500-F150	Video
14.318 MHz	FAR-M2CC-14M318-F150	Video
16.934 MHz	FAR-M2CC-16M934-F150	Audio
18.432 MHz	FAR-M2CC-18M432-F150	Video
24.576 MHz	FAR-M2CC-24M576-F150	Audio
25.175 MHz	FAR-M2CC-25M175-F150	Display
27.000 MHz	FAR-M2CC-27M000-F150	Video
33.869 MHz	FAR-M2CC-33M869-F150	Audio

M2 Series (F150)

■ ELECTRICAL CHARACTERISTICS

Parameter	Symbol	Condition	Value			Unit	Remarks
			Min.	Typ.	Max.		
Current consumption	I_{CC}	Without load	—	5.0	10	mA	
Output voltage	"H"	$V_{IN} = 2.5\text{ V}$	$V_{CC} - 0.5$	5.0	—	V	
	"L"		—	0	+0.5	V	
Oscillation frequency	f_H	$V_{IN} = 5.0\text{ V}$	+2000	—	—	ppm	Nominal frequency reference
	f_L	$V_{IN} = 0.0\text{ V}$	—	—	-2000	ppm	
Frequency stability	$\Delta f(V_{CC})$	$V_{CC} = 4.75\text{ V to } 5.25\text{ V}$ $V_{IN} = 2.5\text{ V}$	-150	—	+150	ppm	$V_{CC} = 5.0\text{ V}$ reference
Frequency stability with temperature	$\Delta f(T_a)$	$V_{IN} = 2.5\text{ V}$ $T_a = -10\text{ }^\circ\text{C to } +70\text{ }^\circ\text{C}$	-500	—	+500	ppm	25°C reference

Unless otherwise specified $T_a = +25\text{ }^\circ\text{C}$, $V_{CC} = 5.0\text{ V}$

■ MEASUREMENT CIRCUIT

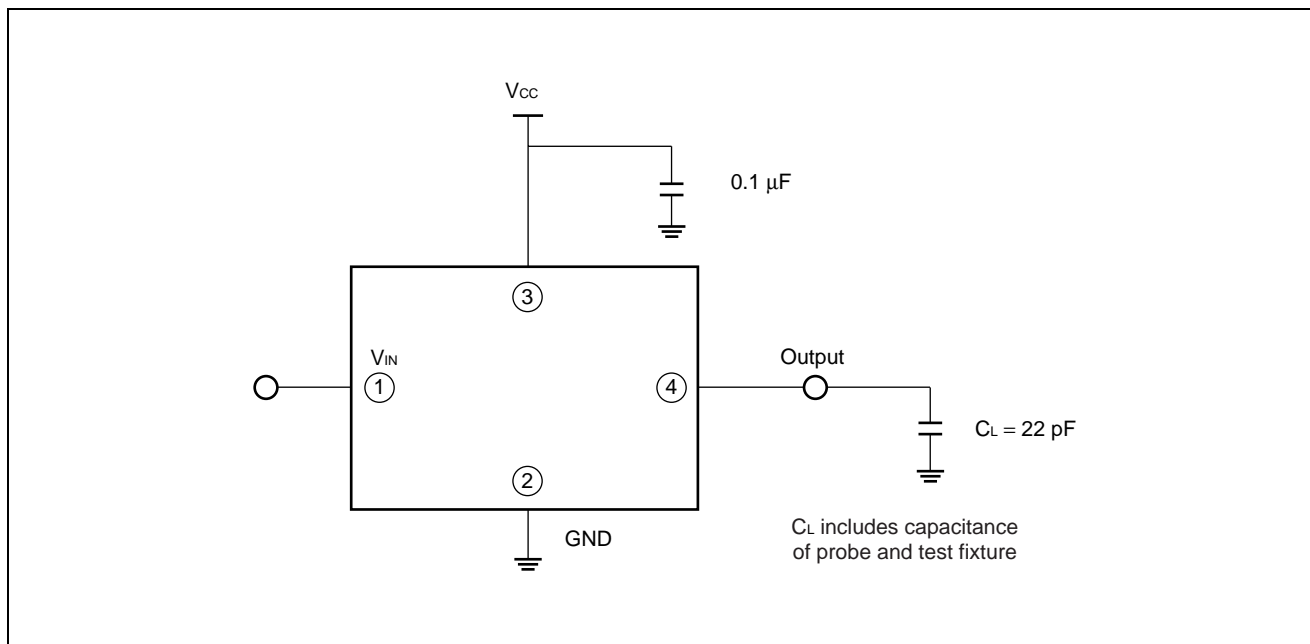

■ TYPICAL CHARACTERISTICS

Part number: FAR-M2CC-16M934-F150

1. Control Voltage vs. Oscillation Frequency Variation

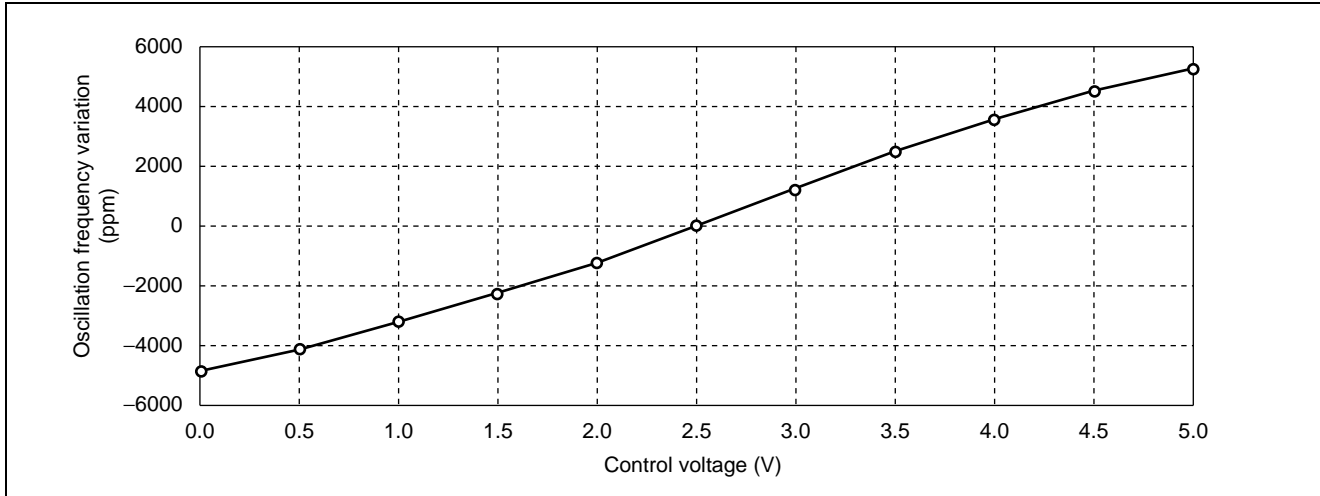

2. Temperature Characteristics

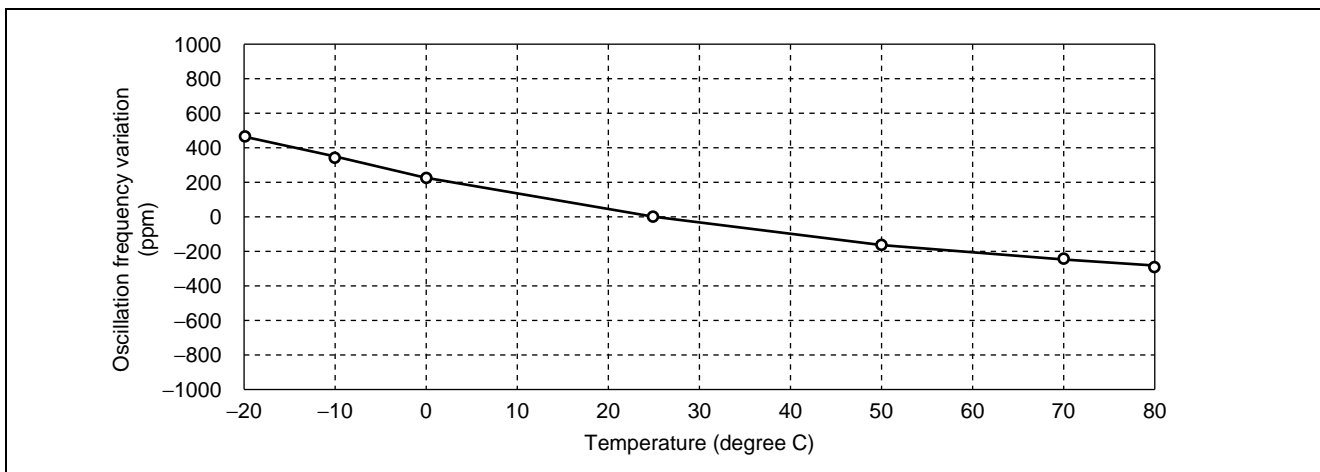

3. Supply Voltage (Vcc) vs. Oscillation Frequency Variation

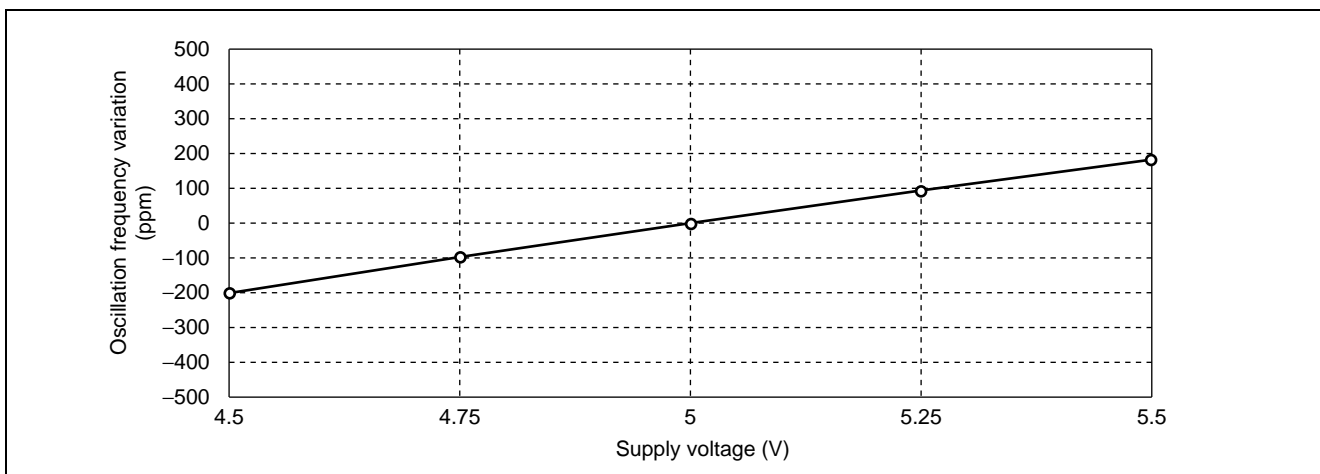

M2 Series (F150)

■ PART NUMBER DESIGNATION

[Designation example]

FAR – M2CC – □□□□□□ – F150 – R
(1) (2)

(1) : Frequency : This specifies the nominal frequency using six alphanumeric characters.
M indicates the decimal point.

[Example] 24.576 MHz → 24M576

(2) : Taping : “-R” means 1000 pcs/reel

■ MARKING

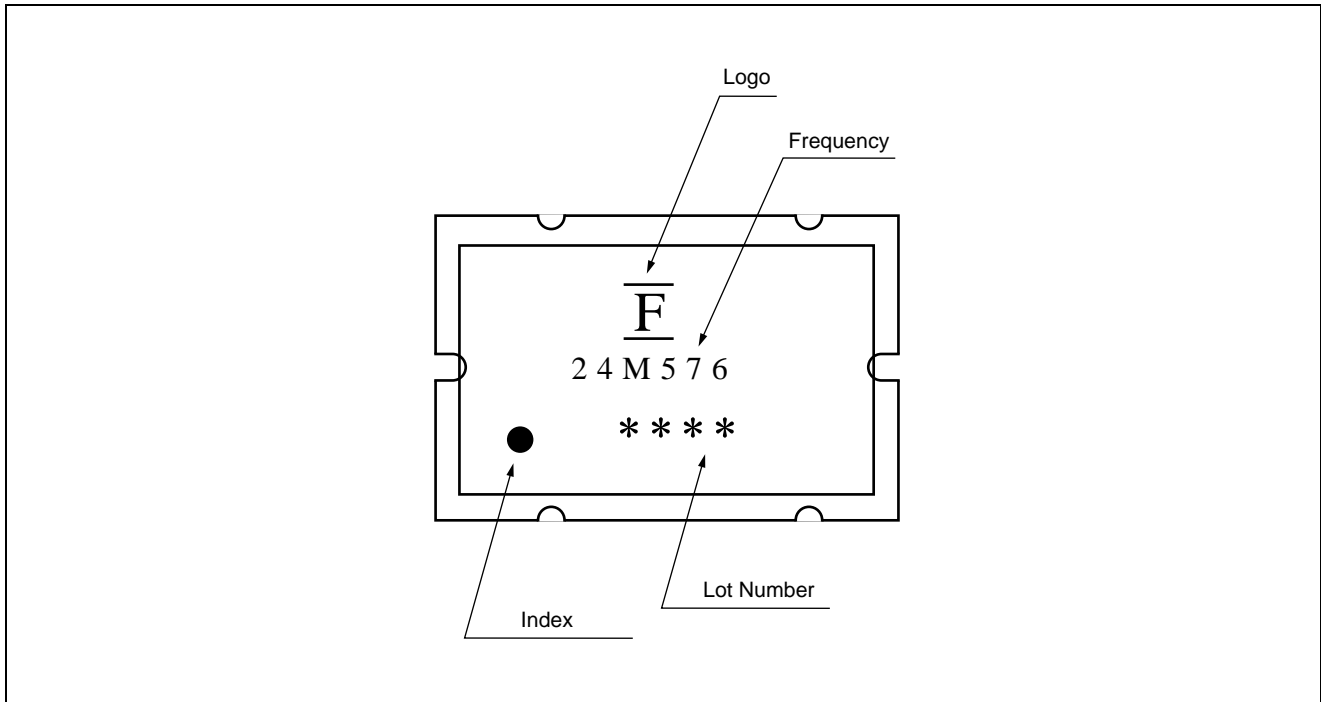

M2 Series (F150)

PACKAGE DIMENSION

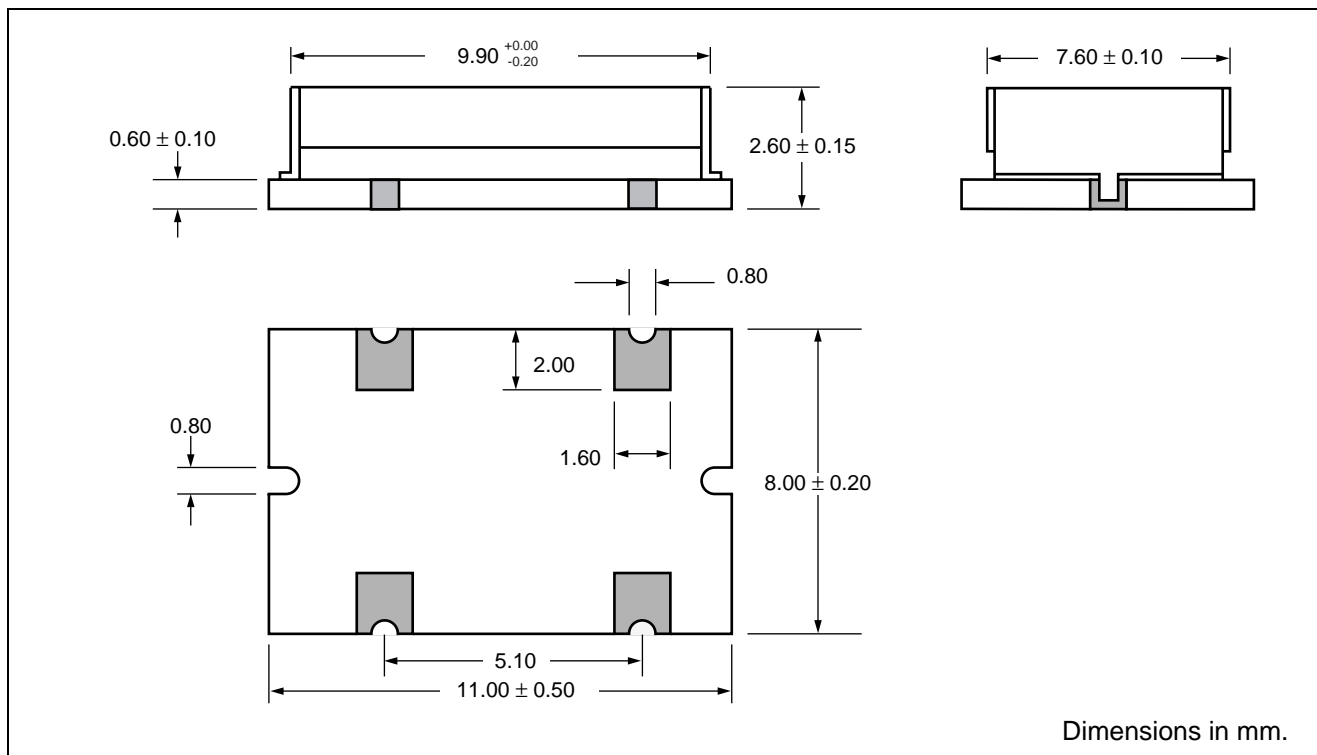

RECOMMENDED LAND PATTERN

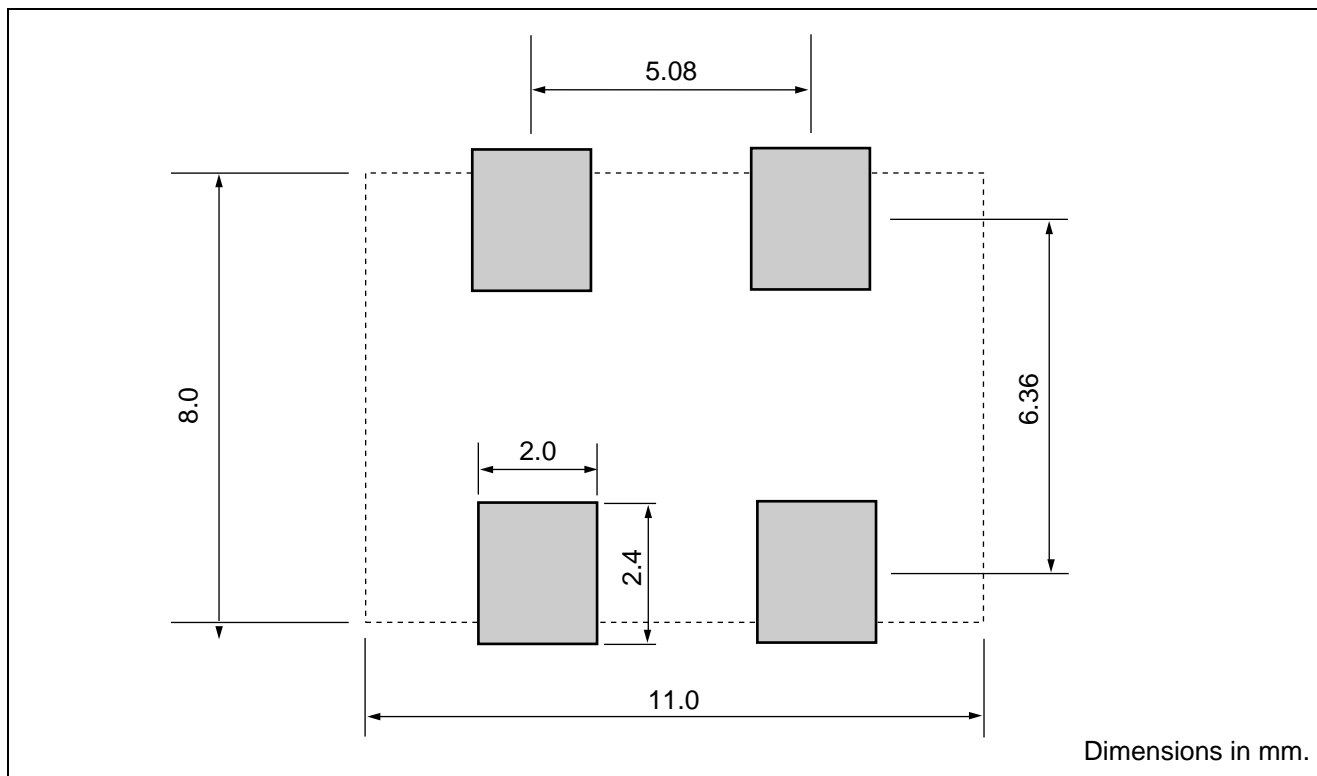

M2 Series (F150)

■ PACKAGE: Reel type

1. Reel Dimensions

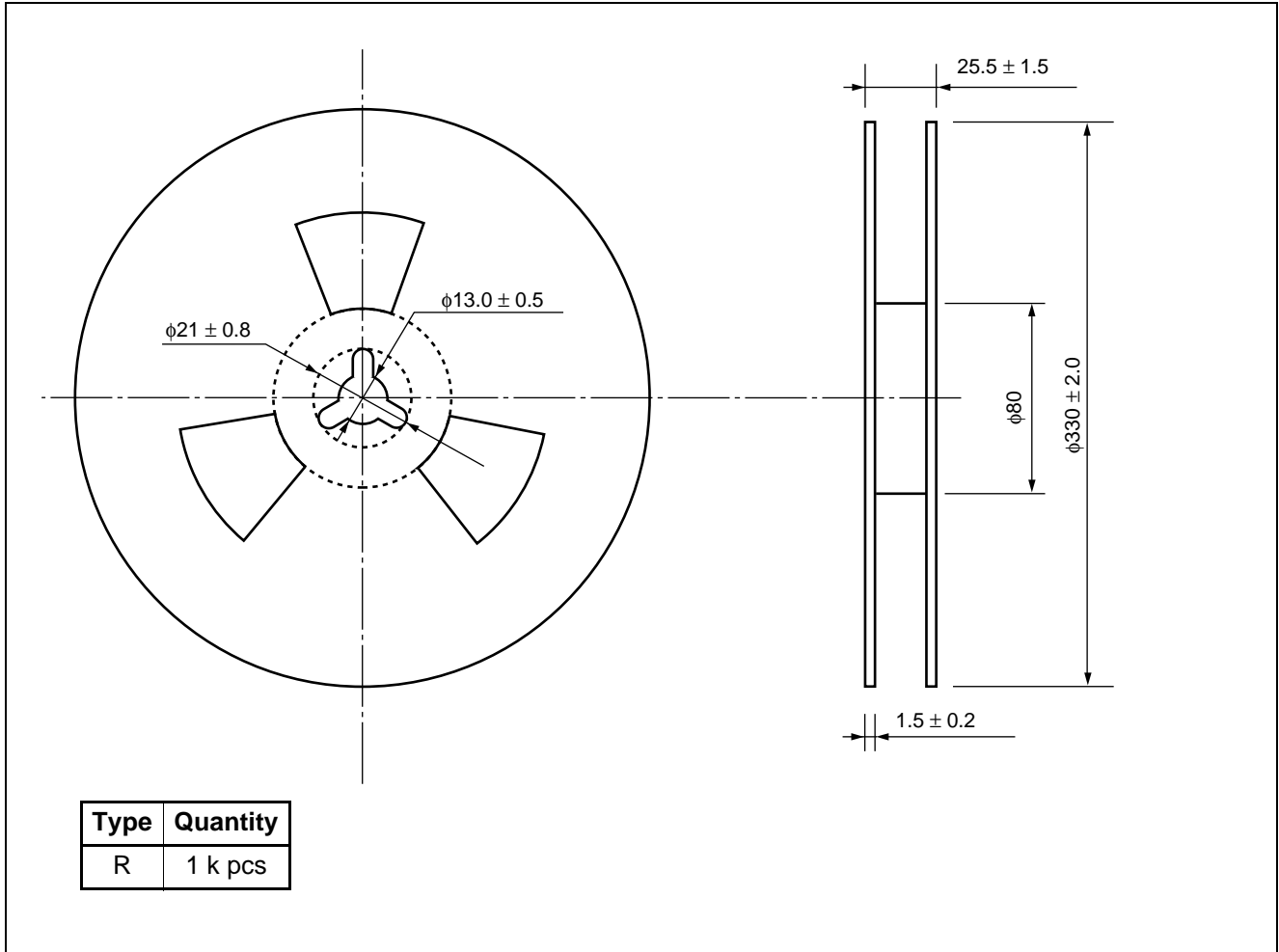

2. Packing style

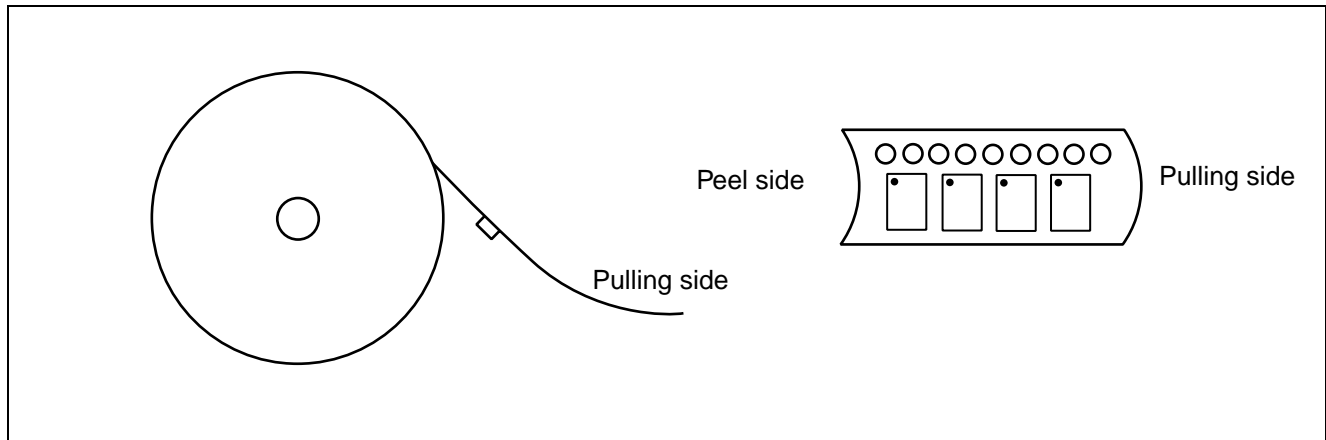

M2 Series (F150)

3. Tape Dimensions

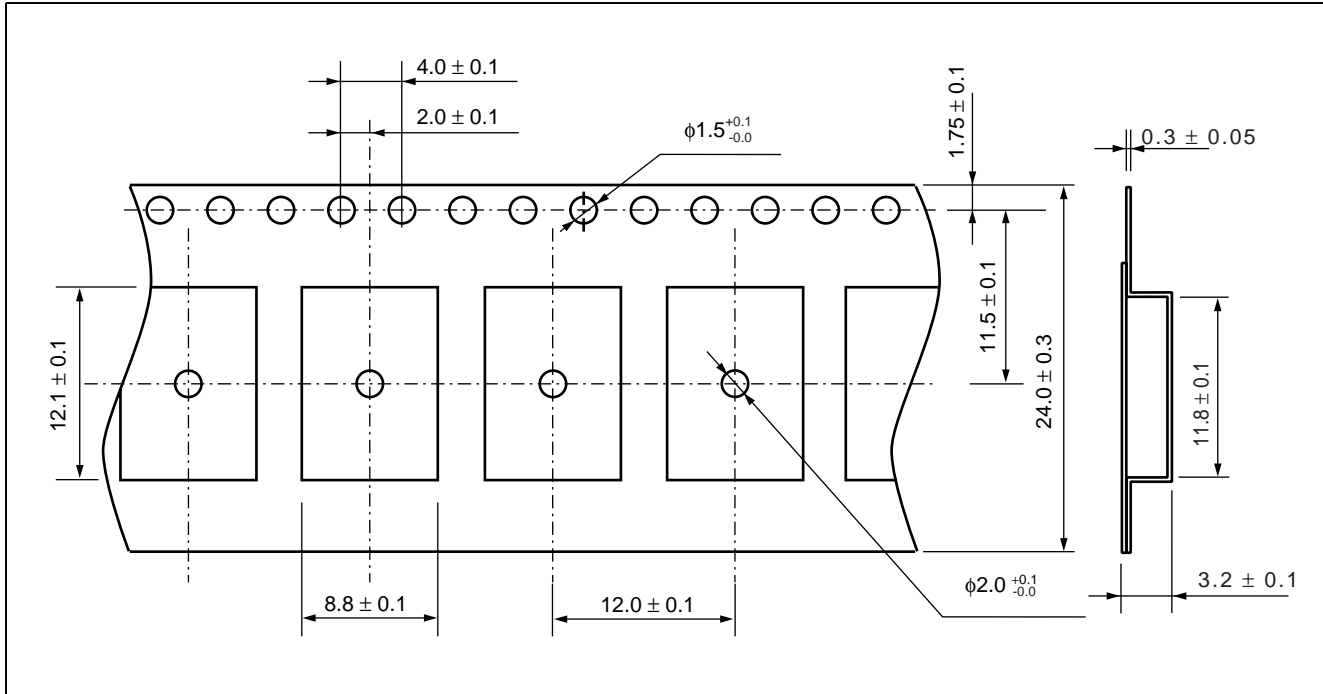

4. Peel strength of top cover tape

Peel off by the force of 0.1 N to 1.0 N under the condition at the right.
(Conforms to JIS C 0806 section 3)

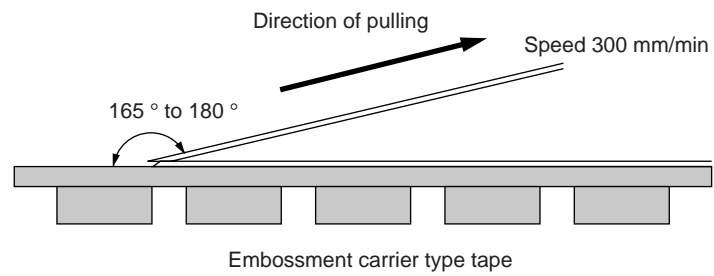

M2 Series (F150)

RECOMMENDED REFLOW PROFILE

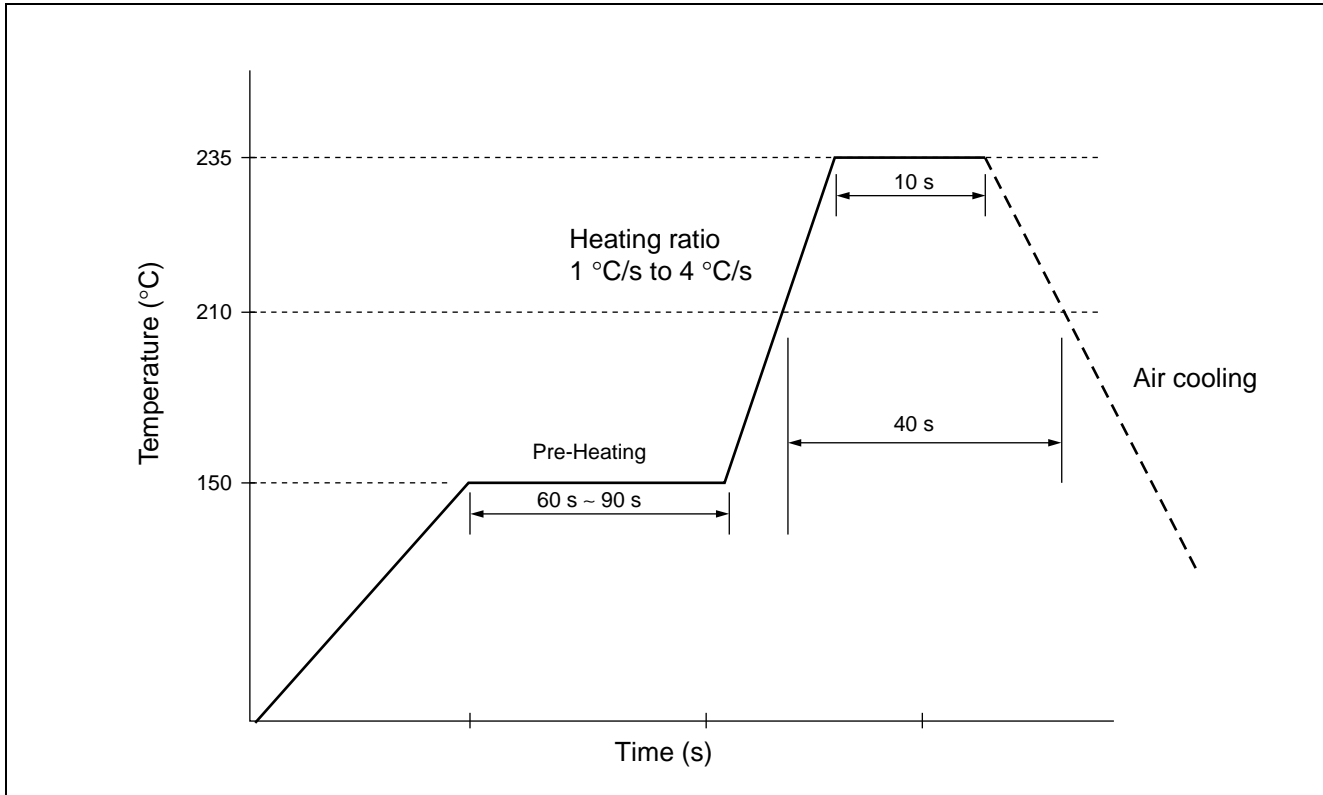

NOTE

A mass-produced product order is accepted by a unit of 1000.

M2 Series (F150)

FUJITSU MEDIA DEVICES LIMITED

For further information please contact:

Japan

FUJITSU MEDIA DEVICE LIMITED
International Sales & Marketing DEPT.
Shin-Yokohama Square Bldg., 14F,
Shin-yokohama 2-3-12,
Kohoku-ku, Yokohama,
Kanagawa 222-0033, Japan
Tel: +81-45-471-0061
Fax: +81-45-471-0076

<http://edevice.fujitsu.com/fmd/>

North and South America

FUJITSU MEDIA DEVICES OF AMERICA, INC.
1731 Technology Drive, Suite 800,
San Jose, CA 95110 U.S.A.
Tel: (1)-408-437-8900
Fax: (1)-408-437-0700

<http://www.fujitsumedia.com/>

Europe

FUJITSU MICROELECTRONICS EUROPE GmbH
Am Siebenstein 6-10,
D-63303 Dreieich-Buchsschlag,
Germany
Tel: +49-6103-690-0
Fax: +49-6103-690-122

<http://www.fujitsu-fme.com/>

Asia Pacific

FUJITSU MICROELECTRONICS ASIA PTE. LTD.
#05-08, 151 Lorong Chuan,
New Tech Park,
Singapore 556741
Tel: +65-281-0770
Fax: +65-281-0220

<http://www.fmap.com.sg/>

F0104

© FUJITSU LIMITED Printed in Japan

All Rights Reserved.

The contents of this document are subject to change without notice. Customers are advised to consult with FUJITSU MEDIA DEVICES sales representatives before ordering.

The information and circuit diagrams in this document are presented as examples of device applications, and are not intended to be incorporated in devices for actual use. Also, FUJITSU MEDIA DEVICES is unable to assume responsibility for infringement of any patent rights or other rights of third parties arising from the use of this information or circuit diagrams.

The products described in this document are designed, and manufactured as contemplated for general use, including without limitation, ordinary industrial use, general office use, personal use, and household use, but are not designed, developed and manufactured as contemplated (1) for use accompanying fatal risks or dangers that, unless extremely high safety is secured, could have a serious effect to the public, and could lead directly to death, personal injury, severe physical damage or other loss (i.e., nuclear reaction control in nuclear facility, aircraft flight control, air traffic control, mass transport control, medical life support system, missile launch control in weapon system), or (2) for use requiring extremely high reliability (i.e., submersible repeater and artificial satellite).

Please note that Fujitsu will not be liable against you and/or any third party for any claims or damages arising in connection with above-mentioned uses of the products.

Any electronic devices have inherently a certain rate of failure. You must protect against injury, damage or loss from such failures by incorporating safety design measures into your facility and equipment such as redundancy, fire protection, and prevention of over-current levels and other abnormal operating conditions.

If any products described in this document represent goods or technologies subject to certain restrictions on export under the Foreign Exchange and Foreign Trade Control Law of Japan, the prior authorization by Japanese government should be required for export of those products from Japan.