

# ASSP

# DUAL REVERSIBLE MOTOR DRIVER

# MB3863

## ■ DESCRIPTION

The MB3863 is an IC motor driver with two independent reverse control functions. It drives motor drives of front-loading VTRs and auto-reverse cassette decks and stepping motors by reversible control at TTL and CMOS levels. A heat protection circuit is incorporated to prevent damage by overheating.

## ■ FEATURES

- Wide voltage range:  $V_{CC} = +4$  to  $+36$  V
- Motor drive current: 500 mA (1.2 A for surge current)
- Two internal independent drivers
- Internal heat protection circuit
- Control at TTL and CMOS level
- Stand-by mode
- Brake function to stop motors
- Internal surge absorption diode
- Stepping motor application
- Symmetrical pin layout

## ■ PACKAGE

20-pin Plastic SOP

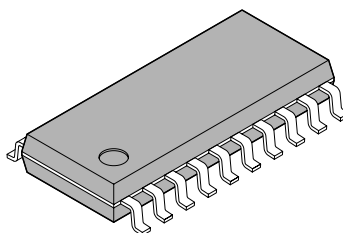

(FPT-20P-M01)

## ■ PIN ASSIGNMENT

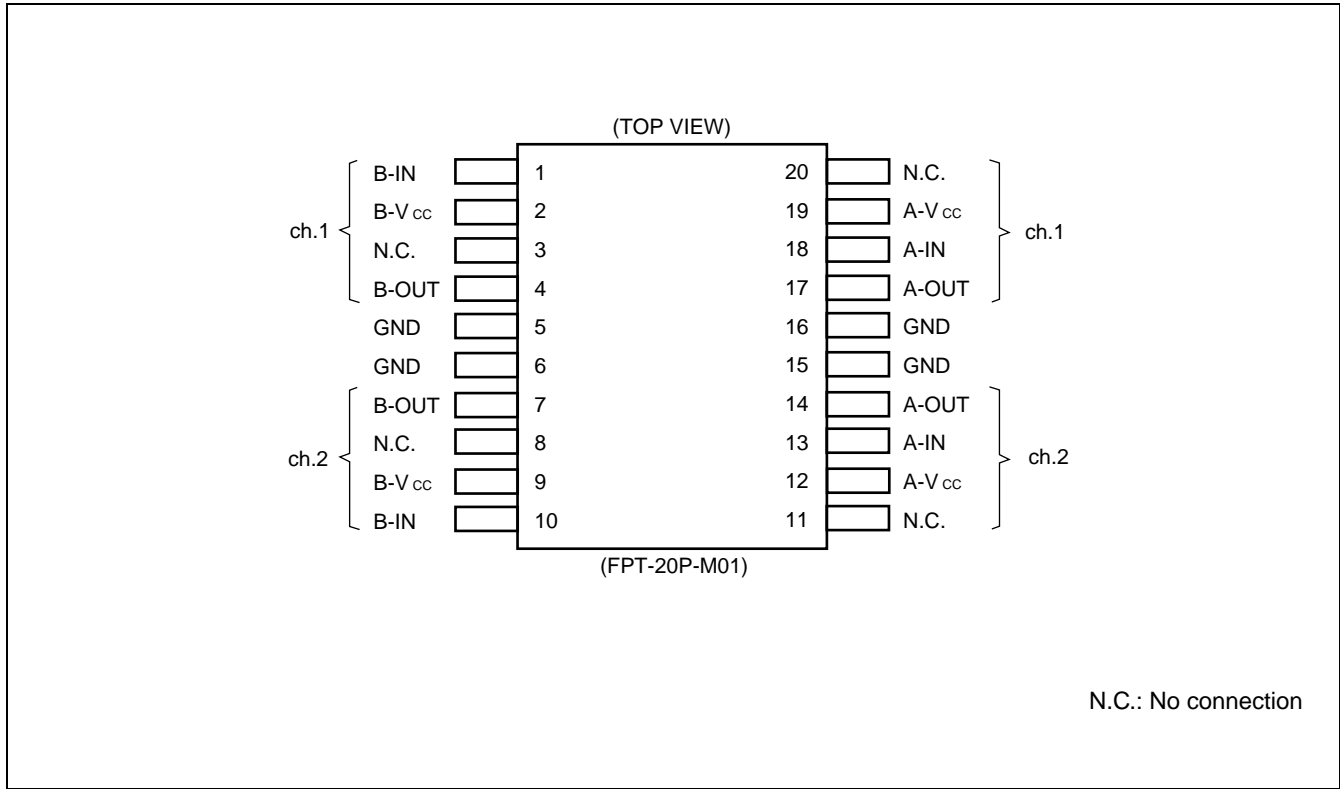

## ■ BLOCK DIAGRAM

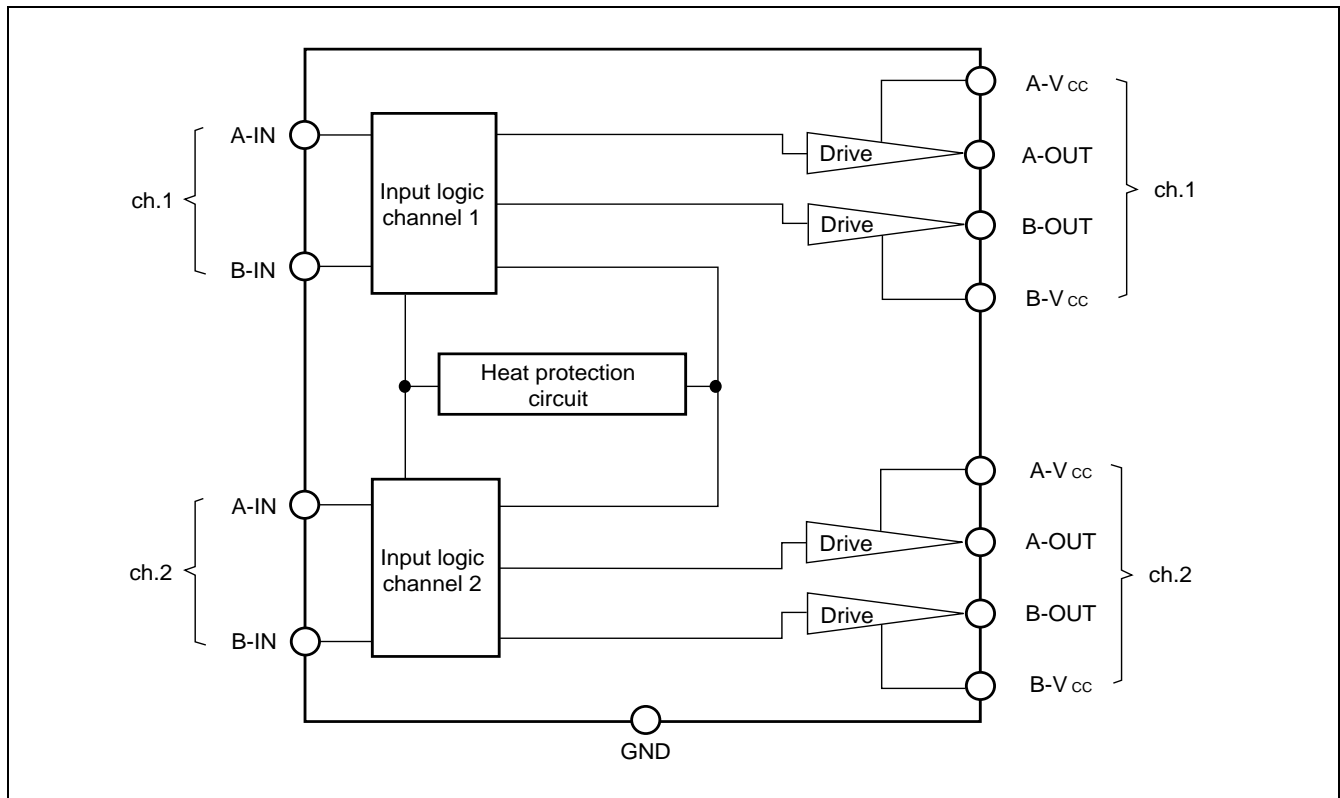

## ■ ABSOLUTE MAXIMUM RATINGS

Parameter	Symbol	Ratings		Unit
		Min.	Max.	
Supply Voltage	V <sub>CC</sub>	—	+38	V
Output Current	I <sub>O</sub>	—	550	mA
Maximum Output Current (within 5 ms)	I <sub>Omax</sub>	—	1.2	A
Allowable Loss	P <sub>D</sub>	—	1.6 (SOP-20)	W
Operating Temperature	T <sub>OP</sub>	-20	+75	°C
Storage Temperature	T <sub>stg</sub>	-55	+150	°C

WARNING: Semiconductor devices can be permanently damaged by application of stress (voltage, current, temperature, etc.) in excess of absolute maximum ratings. Do not exceed these ratings.

## ■ RECOMMENDED OPERATING CONDITIONS

Parameter		Symbol	Ratings		Unit
			Min.	Max.	
Supply Voltage		V <sub>CC</sub>	+4	+36	V
Output Current		I <sub>O</sub>	0	500	mA
Input Voltage	High level	V <sub>IH</sub>	2.4	V <sub>CC</sub> +0.3	V
	Low level	V <sub>IL</sub>	0	0.4	V

WARNING: The recommended operating conditions are required in order to ensure the normal operation of the semiconductor device. All of the device's electrical characteristics are warranted when the device is operated within these ranges.

Always use semiconductor devices within their recommended operating condition ranges. Operation outside these ranges may adversely affect reliability and could result in device failure.

No warranty is made with respect to uses, operating conditions, or combinations not represented on the data sheet. Users considering application outside the listed conditions are advised to contact their FUJITSU representatives beforehand.

# MB3863

## ■ ELECTRICAL CHARACTERISTICS

( $V_{CC} = 24\text{ V}$ ,  $V_{IN} = 2.4\text{ V}$ ,  $T_a = +25\text{ }^\circ\text{C}$ )

Parameter		Symbol	Conditions	Values			Unit
				Min.	Typ.	Max.	
Stand-by Supply Voltage		$I_{CC0}$	$V_{CC} = +24\text{ V}$ , $V_{IA} = V_{IB} = 0\text{ V}$	—	—	100	$\mu\text{A}$
Supply Voltage		$I_{CC1}$	$I_o = 0\text{ mA}$	—	24	38	mA
		$I_{CC2}$	$I_o = 500\text{ mA}$	—	24	—	mA
		$I_{CC3}$	$I_o = 0\text{ mA}$ , $V_{IA} = V_{IB} = +2.4\text{ V}$	—	37	—	mA
Output Voltage	High level	$V_{OH}$	$I_o = 500\text{ mA}$	22.65	23	—	V
	Low level	$V_{OL}$	$I_o = 500\text{ mA}$	—	0.35	0.65	V
Saturated Output Voltage		$V_{SAT}$	$I_o = 500\text{ mA}$	—	1.35	2.00	V
Input Current		$I_{IH}$	$V_{IN} = +2.4\text{ V}$	—	250	400	$\mu\text{A}$
Surge Absorption Diode Voltage in Forward Direction		$V_F$	$I_o = 1.2\text{ A}$	—	2.0	—	V

## ■ OPERATIONS

### 1. Forward and Reverse

Switching control mode A or B pairs Q2 and Q3, or Q1 and Q4, respectively, while reversing the supply current to the motor for each switching. When Q2 and Q3 are in use, B-OUT and A-OUT are High level and Low level, respectively. In this case, current flows B-OUT → motor → A-OUT, causing forward operation as described in the table below.

When Q1 and Q4 are in use, current flows in the reverse direction to the above flow, causing reverse motor operation.

### 2. Brake

Control mode C operates Q2 and Q4 while stopping Q1 and Q3.

Since A-OUT and B-OUT are held at Low level, both poles of the motor are short-circuited and the motor is stopped.

### 3. Stand-by

Control mode D turns Q1 to Q4 OFF and the motor has no current flow.

In this mode, the power supply current is less than 100  $\mu$ A.

Mode	Input mode*		Operation state of output transistor				State of output pin		Output operation mode
	A=IN	B=IN	Q1	Q2	Q3	Q4	A-OUT	B-OUT	
A	1	0	OFF	ON	ON	OFF	L	H	Forward (Reverse)
B	0	1	ON	OFF	OFF	ON	H	L	Reverse (Forward)
C	1	1	OFF	ON	OFF	ON	L	L	Brake
D	0	0	OFF	OFF	OFF	OFF	—	—	Open (High impedance)

\* : Input mode:1: +2.4 V Min.  
0: +0.4 V Max.

# MB3863

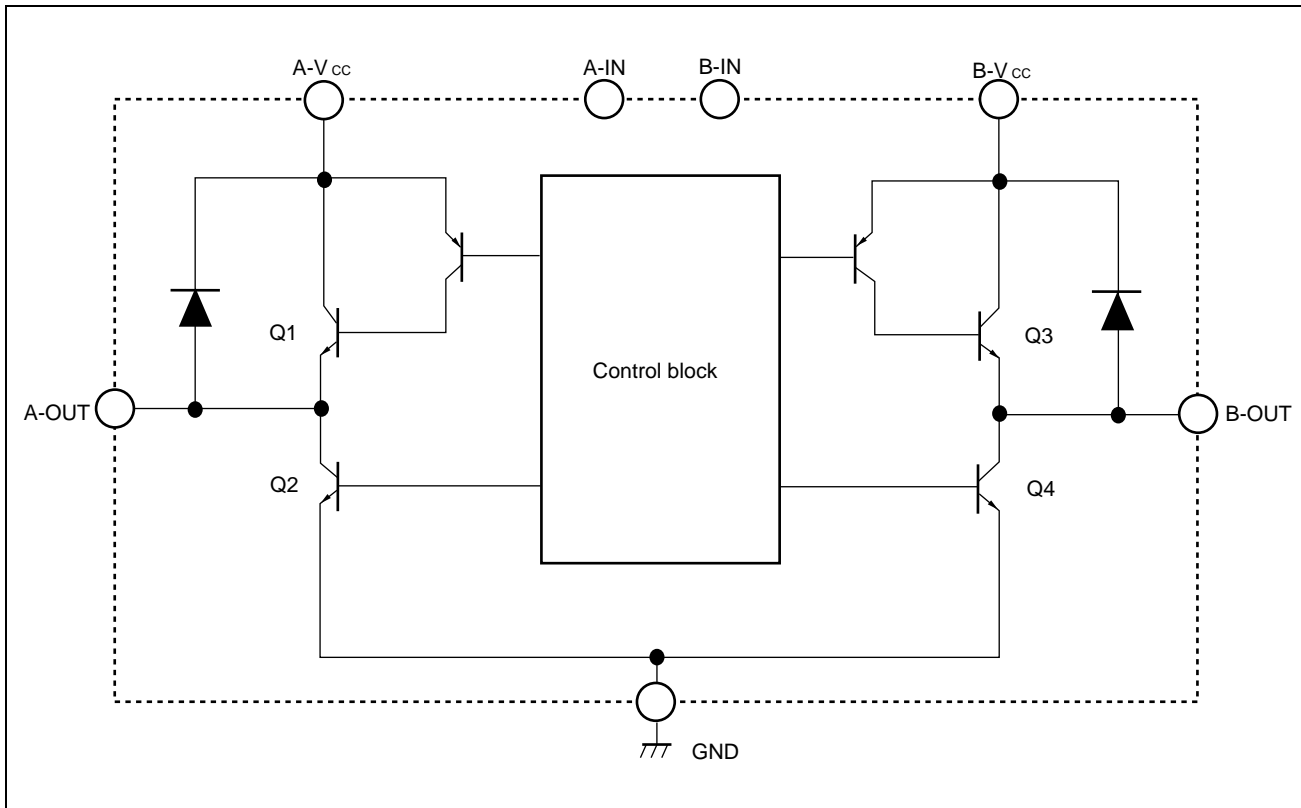

## ■ TYPICAL CONNECTION

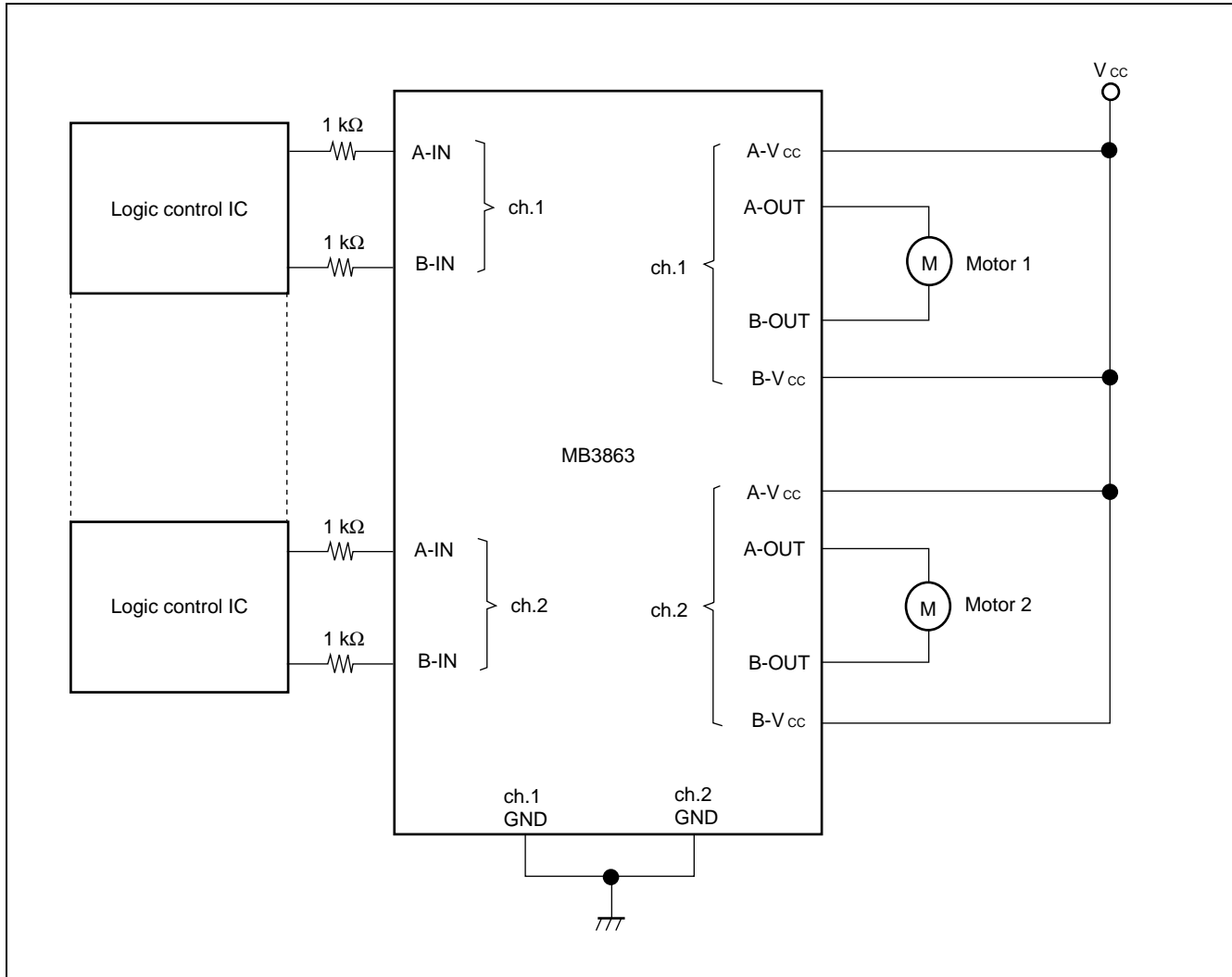

Note : If input voltage is applied when power is not supplied, over-current flows into the device via the input pins. In this case, connect a resistor of at least 1 kΩ in series with the input pins to prevent passage of a large current.

## TYPICAL CHARACTERISTIC CURVES

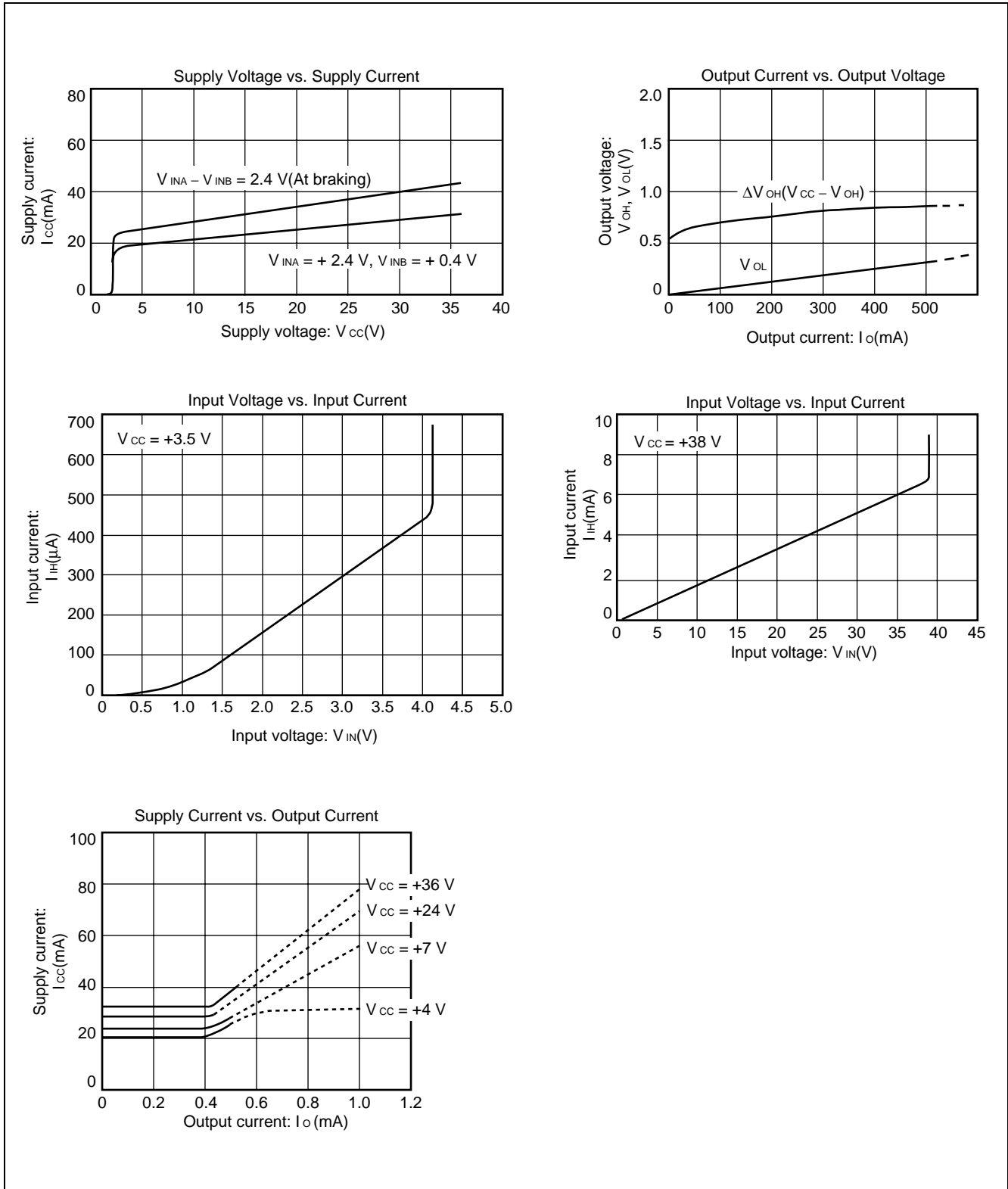

Note : The above characteristic curves are at  $T_a = +25^\circ\text{C}$



## ■ POWER DERATING CHARACTERISTICS

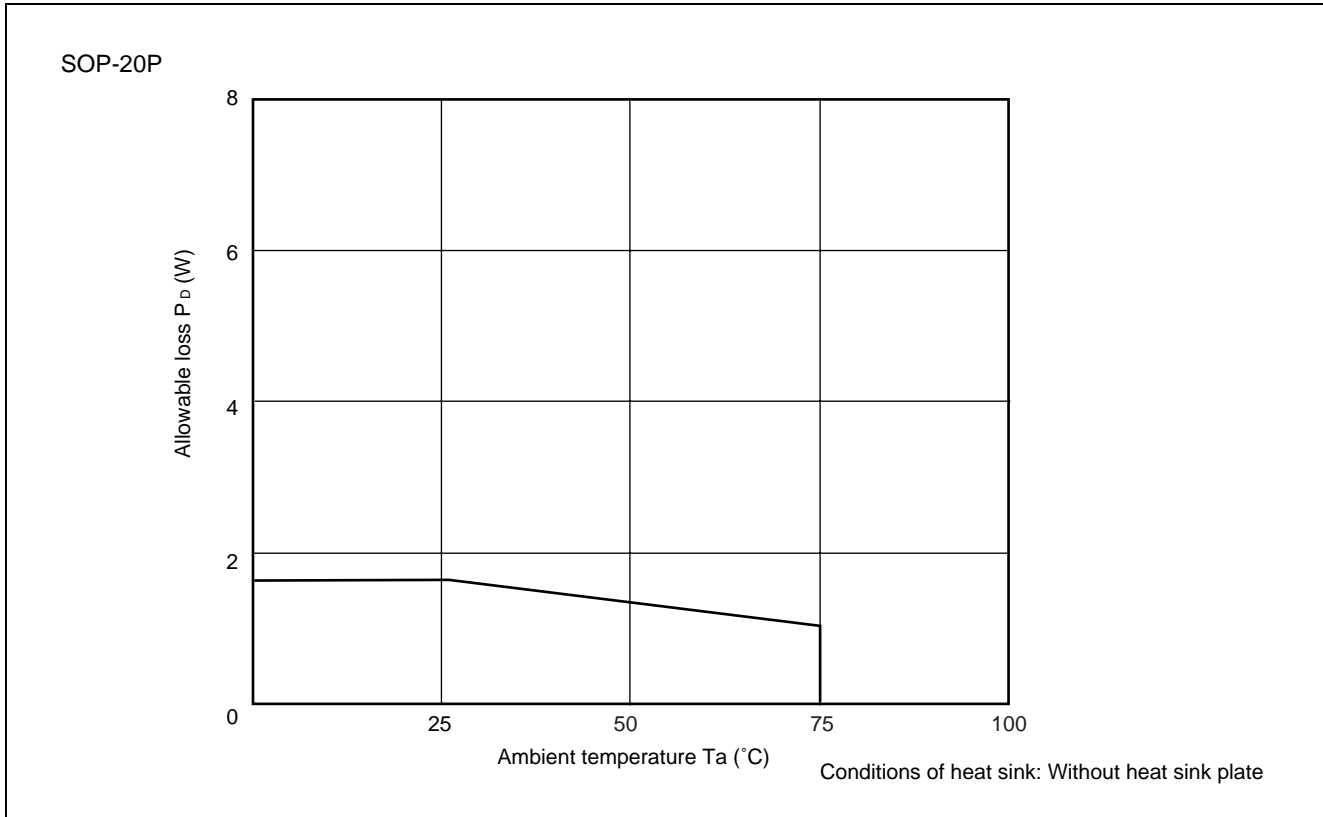

# MB3863

## ■ ORDERING INFORMATION

Part number	Package	Remarks
MB3863PF	20-pin plastic SOP (FPT-20P-M01)	

## PACKAGE DIMENSION

20-pin plastic SOP  
(FPT-20P-M01)

Note 1 : Pins width and pins thickness include plating thickness.  
Note 2 : \*This dimension includes resin protrusion.

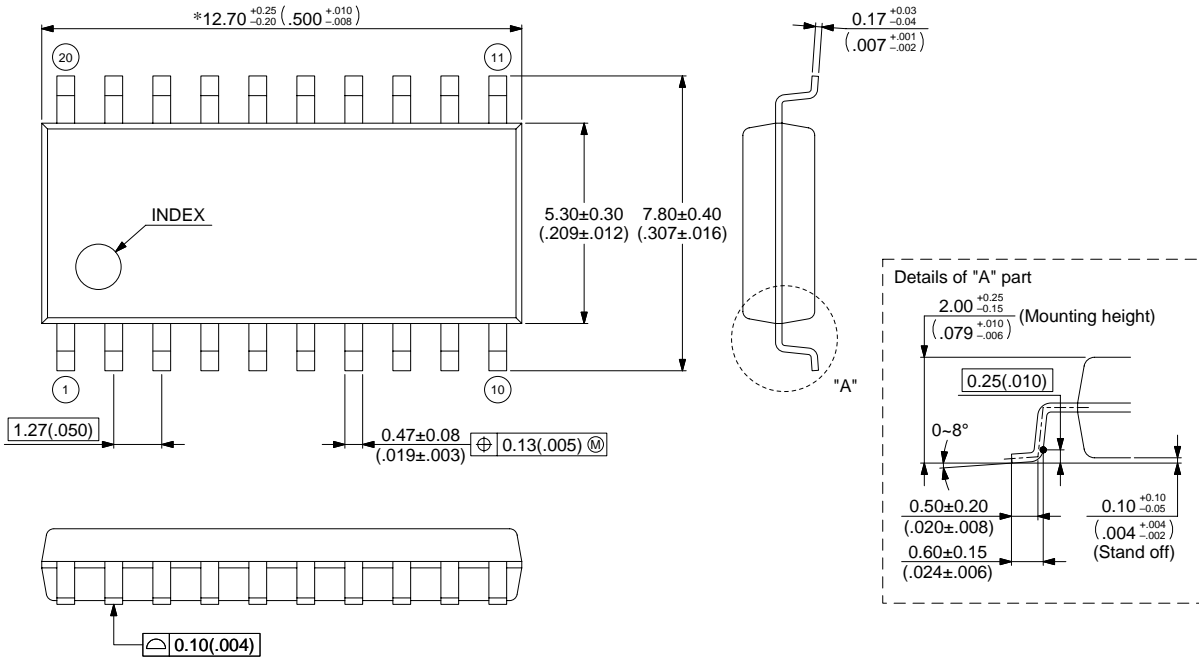

© 2001 FUJITSU LIMITED F20003S-c-6-6

Dimensions in mm (inches)

## FUJITSU LIMITED

*For further information please contact:*

### **Japan**

FUJITSU LIMITED  
Marketing Division  
Electronic Devices  
Shinjuku Dai-Ichi Seimei Bldg. 7-1,  
Nishishinjuku 2-chome, Shinjuku-ku,  
Tokyo 163-0721, Japan  
Tel: +81-3-5322-3353  
Fax: +81-3-5322-3386

<http://edevice.fujitsu.com/>

### **North and South America**

FUJITSU MICROELECTRONICS, INC.  
3545 North First Street,  
San Jose, CA 95134-1804, U.S.A.  
Tel: +1-408-922-9000  
Fax: +1-408-922-9179

Customer Response Center  
*Mon. - Fri.: 7 am - 5 pm (PST)*  
Tel: +1-800-866-8608  
Fax: +1-408-922-9179

<http://www.fujitsumicro.com/>

### **Europe**

FUJITSU MICROELECTRONICS EUROPE GmbH  
Am Siebenstein 6-10,  
D-63303 Dreieich-Buchsschlag,  
Germany  
Tel: +49-6103-690-0  
Fax: +49-6103-690-122

<http://www.fme.fujitsu.com/>

### **Asia Pacific**

FUJITSU MICROELECTRONICS ASIA PTE. LTD.  
#05-08, 151 Lorong Chuan,  
New Tech Park,  
Singapore 556741  
Tel: +65-281-0770  
Fax: +65-281-0220

<http://www.fmal.fujitsu.com/>

### **Korea**

FUJITSU MICROELECTRONICS KOREA LTD.  
1702 KOSMO TOWER, 1002 Daechi-Dong,  
Kangnam-Gu, Seoul 135-280  
Korea  
Tel: +82-2-3484-7100  
Fax: +82-2-3484-7111

F0108

© FUJITSU LIMITED Printed in Japan

All Rights Reserved.

The contents of this document are subject to change without notice. Customers are advised to consult with FUJITSU sales representatives before ordering.

The information and circuit diagrams in this document are presented as examples of semiconductor device applications, and are not intended to be incorporated in devices for actual use. Also, FUJITSU is unable to assume responsibility for infringement of any patent rights or other rights of third parties arising from the use of this information or circuit diagrams.

The products described in this document are designed, and manufactured as contemplated for general use, including without limitation, ordinary industrial use, general office use, personal use, and household use, but are not designed, developed and manufactured as contemplated (1) for use accompanying fatal risks or dangers that, unless extremely high safety is secured, could have a serious effect to the public, and could lead directly to death, personal injury, severe physical damage or other loss (i.e., nuclear reaction control in nuclear facility, aircraft flight control, air traffic control, mass transport control, medical life support system, missile launch control in weapon system), or (2) for use requiring extremely high reliability (i.e., submersible repeater and artificial satellite).

Please note that Fujitsu will not be liable against you and/or any third party for any claims or damages arising in connection with above-mentioned uses of the products.

Any semiconductor devices have inherently a certain rate of failure. You must protect against injury, damage or loss from such failures by incorporating safety design measures into your facility and equipment such as redundancy, fire protection, and prevention of over-current levels and other abnormal operating conditions.

If any products described in this document represent goods or technologies subject to certain restrictions on export under the Foreign Exchange and Foreign Trade Control Law of Japan, the prior authorization by Japanese government should be required for export of those products from Japan.