

ASSP

Dual Serial Input PLL Frequency Synthesizer

MB15F08SL

■ DESCRIPTION

The Fujitsu MB15F08SL is a serial input Phase Locked Loop (PLL) frequency synthesizer with a 2500 MHz and a 1100 MHz prescalers. The 2500 MHz prescaler, and 1100 MHz prescaler have a dual modulus division ratio of 32/33 or 64/65 and 16/17 or 32/33 enabling pulse swallow operation.

The supply voltage range is between 2.4 V and 3.6 V.

The MB15F08SL uses the latest BiCMOS process. As a result, the supply current is typically 7.0 mA at 2.7 V. A refined charge pump supplies a well-balanced output current of 1.5 mA or 6 mA. The charge pump current is selectable by serial data.

MB15F08SL is ideally suited for wireless mobile communications.

■ FEATURES

- High frequency operation: RX synthesizer: 2500 MHz max
TX synthesizer: 1100 MHz max
- Low power supply voltage: $V_{CC} = 2.4$ to 3.6 V
- Ultra Low power supply current: $I_{CC} = 7.0$ mA typ. ($V_{CC} = 2.7$ V, $T_a = +25^\circ\text{C}$, in TX, RX locking state)
 $I_{CC} = 7.5$ mA typ. ($V_{CC} = 3.0$ V, $T_a = +25^\circ\text{C}$, in TX, RX locking state)
- Direct power saving function: Power supply current in power saving mode
Typ. 0.1 μA ($V_{CC} = 3\text{V}$, $T_a = +25^\circ\text{C}$), Max. 10 μA ($V_{CC} = 3\text{V}$)
- Dual modulus prescaler: 2500 MHz prescaler (32/33 or 64/65)/1100 MHz prescaler (16/17 or 32/33)
- Serial input 14-bit programmable reference divider: $R = 3$ to 16,383
- Serial input programmable divider consisting of:
 - Binary 7-bit swallow counter: 0 to 127
 - Binary 11-bit programmable counter: 3 to 2,047
- Software selectable charge pump current
- On-chip phase control for phase comparator
- Operating temperature: $T_a = -40$ to $+85^\circ\text{C}$

■ PACKAGES

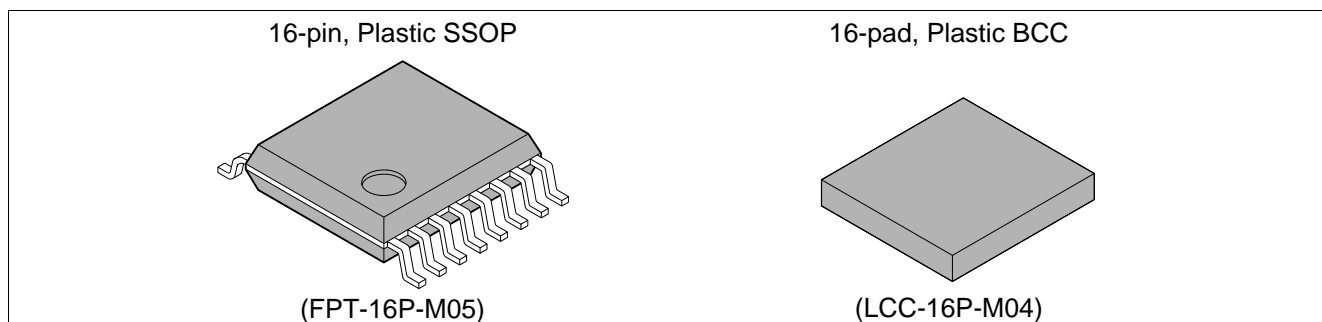

MB15F08SL

■ PIN ASSIGNMENTS

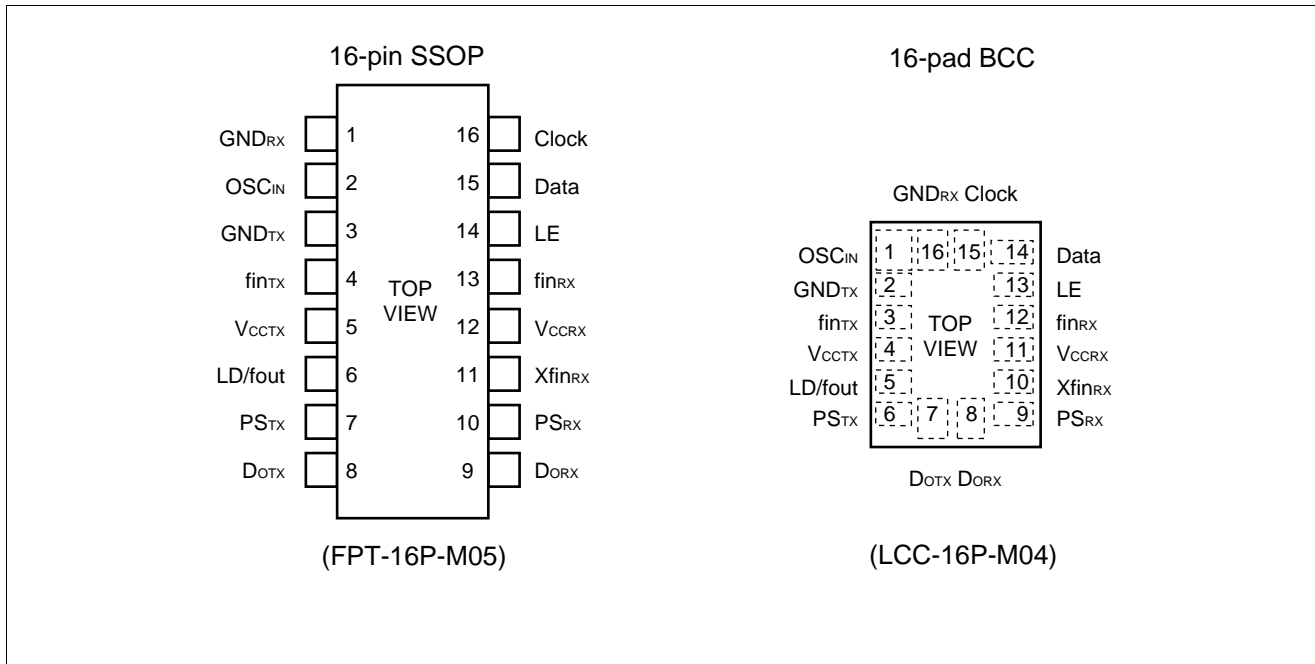

■ PIN DESCRIPTION

Pin no.		Pin name	I/O	Descriptions
SSOP	BCC			
1	16	GND _{RX}	–	Ground for RX-PLL section.
2	1	OSC _{IN}	I	The programmable reference divider input. TCXO should be connected with a AC coupling capacitor.
3	2	GND _{TX}	–	Ground for the TX-PLL section.
4	3	fin _{TX}	I	Prescaler input pin for the TX-PLL. Connection to an external VCO should be via AC coupling.
5	4	V _{CCTX}	–	Power supply voltage input pin for the TX-PLL section.
6	5	LD/fout	O	Lock detect signal output (LD)/phase comparator monitoring output (fout). The output signal is selected by LDS bit in the serial data. LDS bit = "H" ; outputs fout signal LDS bit = "L" ; outputs LD signal
7	6	PS _{TX}	I	Power saving mode control for the TX-PLL section. This pin must be set at "L" during Power-ON. (Open is prohibited.) PS _{TX} = "H" ; Normal mode PS _{TX} = "L" ; Power saving mode
8	7	Do _{TX}	O	Charge pump output for the TX-PLL section. Phase characteristics of the phase detector can be selected via programming of the FC-bit.
9	8	Do _{RX}	O	Charge pump output for the RX-PLL section. Phase characteristics of the phase detector can be selected via programming of the FC-bit.
10	9	PS _{RX}	I	Power saving mode control for the RX-PLL section. This pin must be set at "L" during Power-ON. (Open is prohibited.) PS _{RX} = "H" ; Normal mode PS _{RX} = "L" ; Power saving mode
11	10	Xfin _{RX}	I	Prescaler complementary input for the RX-PLL section. This pin should be grounded via a capacitor.
12	11	V _{CCR_X}	–	Power supply voltage input pin for the RX-PLL section, the shift register and the oscillator input buffer. When power is OFF, latched data of RX-PLL is lost.
13	12	fin _{RX}	I	Prescaler input pin for the RX-PLL. Connection to an external VCO should be via AC coupling.
14	13	LE	I	Load enable signal input (with a schmitt trigger input buffer.) When the LE bit is set "H", data in the shift register is transferred to the corresponding latch according to the control bit in the serial data.
15	14	Data	I	Serial data input (with a schmitt trigger input buffer.) A data is transferred to the corresponding latch (TX-ref counter, TX-prog. counter, RX-ref. counter, RX-prog. counter) according to the control bit in the serial data.
16	15	Clock	I	Clock input for the 23-bit shift register (with a schmitt trigger input buffer.) One bit of data is shifted into the shift register on a rising edge of the clock.

MB15F08SL

■ BLOCK DIAGRAM

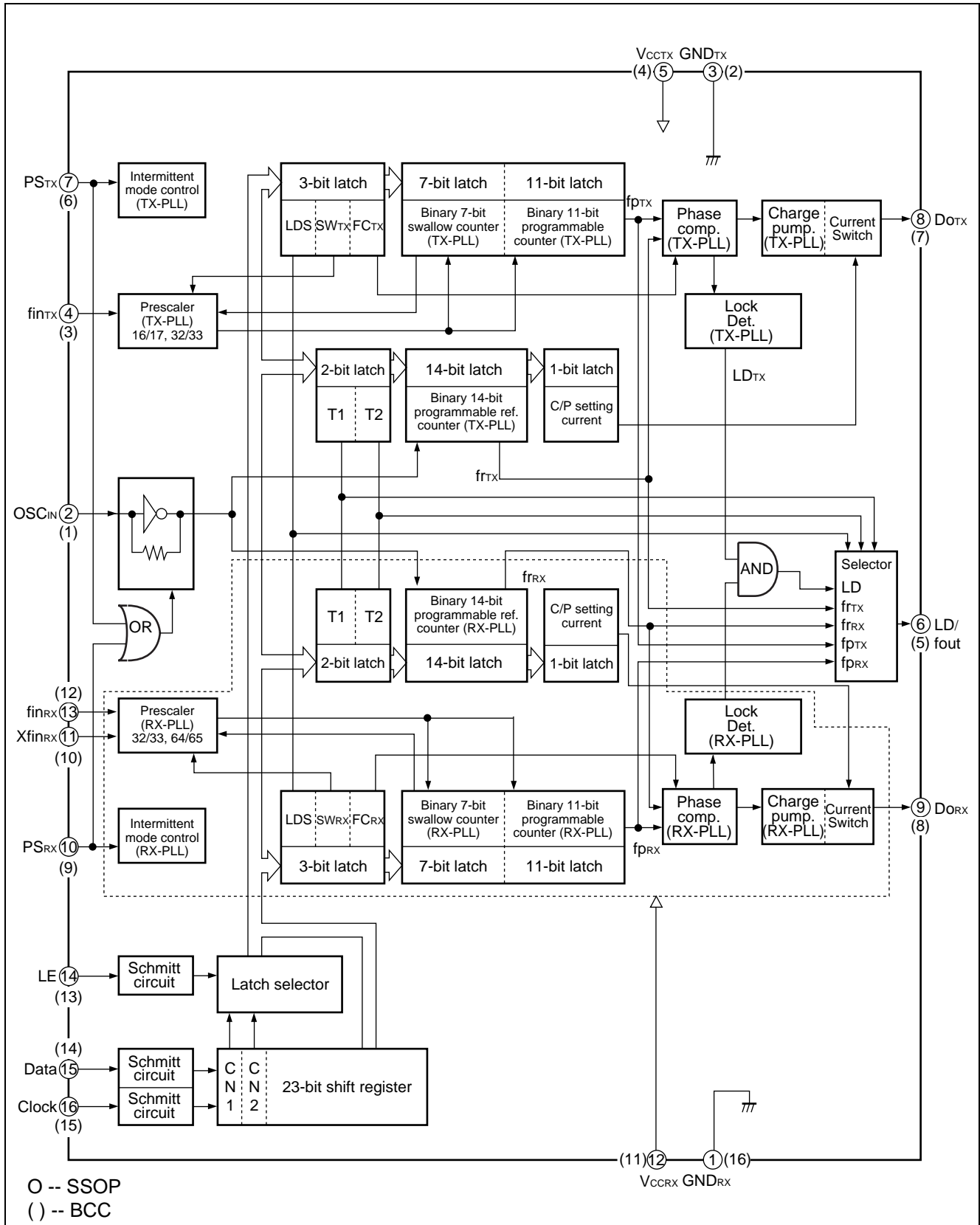

■ ABSOLUTE MAXIMUM RATINGS

Parameter	Symbol	Rating		Unit	Remark
		Min.	Max.		
Power supply voltage	V_{CC}	-0.5	+4.0	V	
Input voltage	V_I	-0.5	$V_{CC} + 0.5$	V	
Output voltage	V_O	GND	V_{CC}	V	
Storage temperature	T_{stg}	-55	+125	°C	

WARNING: Semiconductor devices can be permanently damaged by application of stress (voltage, current, temperature, etc.) in excess of absolute maximum ratings. Do not exceed these ratings.

■ RECOMMENDED OPERATING CONDITIONS

Parameter	Symbol	Value			Unit	Remark
		Min.	Typ.	Max.		
Power supply voltage	V_{CC}	2.4	3.0	3.6	V	
Input voltage	V_I	GND	-	V_{CC}	V	
Operating temperature	T_a	-40	-	+85	°C	

WARNING: The recommended operating conditions are required in order to ensure the normal operation of the semiconductor device. All of the device's electrical characteristics are warranted when the device is operated within these ranges.

Always use semiconductor devices within their recommended operating condition ranges. Operation outside these ranges may adversely affect reliability and could result in device failure.

No warranty is made with respect to uses, operating conditions, or combinations not represented on the data sheet. Users considering application outside the listed conditions are advised to contact their FUJITSU representatives beforehand.

MB15F08SL

■ ELECTRICAL CHARACTERISTICS

(V_{CC} = 2.4 to 3.6 V, T_a = -40 to +85°C)

Parameter	Symbol	Condition		Value			Unit	
				Min.	Typ.	Max.		
Power supply current*1	I _{CC_{TX}} ^{*1}	fin _{TX} = 1100 MHz	V _{CC_{TX}} = 2.7 V (V _{CC_{TX}} = 3.0 V)	–	2.6 (2.8)	–	mA	
	I _{CC_{RX}} ^{*1}	fin _{RX} = 2500 MHz	V _{CC_{RX}} = 2.7 V (V _{CC_{RX}} = 3.0 V)	–	4.4 (4.7)	–	mA	
Power saving current	I _{PS}	PS _{TX} = PS _{RX} = "L"		–	0.1*2	10	μA	
Operating frequency	fin _{TX} ^{*3}	fin _{TX}	TX PLL	100	–	1100	MHz	
	fin _{RX} ^{*3}	fin _{RX}	RX PLL	400	–	2500	MHz	
	OSC _{IN}	fosc	–	3	–	40	MHz	
Input sensitivity	fin _{TX}	Pfin _{TX}	TX PLL, 50 Ω system	–10	–	+2	dBm	
	fin _{RX} ^{*8}	Pfin _{RX}	RX PLL, 50 Ω system	–15	–	+2	dBm	
	OSC _{IN}	V _{OSC}	–	0.5	–	V _{CC}	Vp-p	
"H" level input voltage	Data, Clock, LE,	V _{IH}	Schmitt trigger input	V _{CC} × 0.7 + 0.4	–	–	V	
"L" level input voltage		V _{IL}	Schmitt trigger input	–	–	V _{CC} × 0.3 – 0.4		
"H" level input voltage	PS	V _{IH}	–	V _{CC} × 0.7	–	–	V	
"L" level input voltage		V _{IL}	–	–	–	V _{CC} × 0.3		
"H" level input current	Data, Clock, LE, PS	I _{IH} ^{*4}	–	–1.0	–	+1.0	μA	
"L" level input current		I _{IL} ^{*4}	–	–1.0	–	+1.0		
"H" level input current	OSC _{IN}	I _{IH}	–	0	–	+100	μA	
"L" level input current		I _{IL} ^{*4}	–	–100	–	0		
"H" level output voltage	LD/fout	V _{OH}	V _{CC} = 3 V, I _{OH} = –1 mA	V _{CC} – 0.4	–	–	V	
"L" level output voltage		V _{OL}	V _{CC} = 3 V, I _{OL} = 1 mA	–	–	0.4		
"H" level output voltage	Do _{TX} Do _{RX}	V _{DOH}	V _{CC} = 3 V, I _{DOH} = –0.5 mA	V _{CC} – 0.4	–	–	V	
"L" level output voltage		V _{DOL}	V _{CC} = 3 V, I _{DOL} = 0.5 mA	–	–	0.4		
High impedance cutoff current	Do _{TX} Do _{RX}	I _{OFF}	V _{CC} = 3 V, V _{OFF} = 0.5 V to V _{CC} – 0.5V	–	–	2.5	nA	
"H" level output current	LD/fout	I _{OH} ^{*4}	V _{CC} = 3 V	–	–	–1.0	mA	
"L" level output current		I _{DOL} ^{*4}	V _{CC} = 3 V	1.0	–	–		
"H" level output current	Do _{TX} Do _{RX}	I _{DOH} ^{*4}	V _{CC} = 3 V, V _{DOH} = V _{CC} /2, T _a = +25°C	CS bit = "H"	–	–6.0	–	mA
				CS bit = "L"	–	–1.5	–	

(Continued)

(Continued)

($V_{CC} = 2.4$ to 3.6 V, $T_a = -40$ to $+85^\circ\text{C}$)

Parameter	Symbol	Condition	Value			Unit		
			Min.	Typ.	Max.			
“L” level output current	DoTX DoRX	IDOL	$V_{CC} = 3$ V, $V_{DOL} = V_{CC}/2$, $T_a = +25^\circ\text{C}$	CS bit = “H”	–	6.0	–	mA
				CS bit = “L”	–	1.5	–	
Charge pump current rate	IDOL/IDOH	IDOMT ^{*5}	$V_{DO} = V_{CC}/2$	–	3	–	%	
	vs VDO	IDOVD ^{*6}	0.5 V $\leq V_{DO} \leq V_{CC} - 0.5$ V	–	10	–	%	
	vs Ta	IDOTA ^{*7}	$-40^\circ\text{C} \leq T_a \leq +85^\circ\text{C}$, $V_{DO} = V_{CC}/2$	–	10	–	%	

*1: Conditions; $f_{osc} = 12$ MHz, $T_a = +25^\circ\text{C}$, SW=L, in locking state.

*2: $V_{CCTX} = V_{CCRX} = 3.0$ V, $f_{osc} = 12.8$ MHz, $T_a = +25^\circ\text{C}$, in power saving state.

*3: AC coupling. 1000pF capacitor is connected under the condition of min. operating frequency.

*4: The symbol “–” (minus) means direction of current flow.

*5: $V_{CC} = 3.0$ V, $T_a = +25^\circ\text{C}$ $(|I_3| - |I_4|) / [(|I_3| + |I_4|) / 2] \times 100(\%)$

*6: $V_{CC} = 3.0$ V, $T_a = +25^\circ\text{C}$ $[(|I_2| - |I_1|) / 2] / [(|I_1| + |I_2|) / 2] \times 100(\%)$ (Applied to each IDOL, IDOH)

*7: $V_{CC} = 3.0$ V, $[|I_{DO(85^\circ\text{C})} - I_{DO(-40^\circ\text{C})}| / 2] / [(|I_{DO(85^\circ\text{C})} + I_{DO(-40^\circ\text{C})}|) / 2] \times 100(\%)$ (Applied to each IDOL, IDOH)

*8: fin operating frequency Input sensitivity(Min.)

400 MHz \leq fin \leq 2200 MHz –15 dBm

2200 MHz < fin \leq 2500 MHz –10 dBm

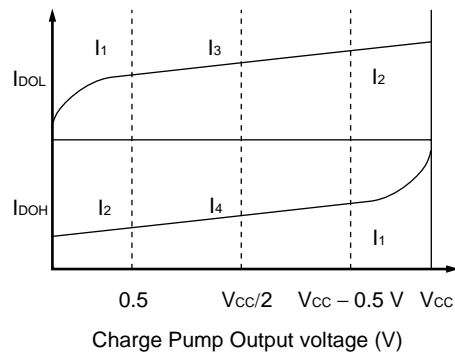

MB15F08SL

FUNCTIONAL DESCRIPTION

The divide ratio can be calculated using the following equation:

$$f_{vco} = [(M \times N) + A] \times f_{osc} \div R \quad (A < N)$$

- f_{vco} : Output frequency of external voltage controlled oscillator (VCO)
- M : Preset divide ratio of dual modulus prescaler (16 or 32 for TX-PLL, 32 or 64 for RX-PLL)
- N : Preset divide ratio of binary 11-bit programmable counter (3 to 2,047)
- A : Preset divide ratio of binary 7-bit swallow counter ($0 \leq A \leq 127$)
- f_{osc} : Reference oscillation frequency
- R : Preset divide ratio of binary 14-bit programmable reference counter (3 to 16,383)

Serial Data Input

Serial data is entered using three pins, Data pin, Clock pin, and LE pin. Programmable dividers of TX/RX-PLL sections, programmable reference dividers of TX/RX-PLL sections are controlled individually.

Serial data of binary data is entered through Data pin.

On rising edge of Clock, one bit of serial data is transferred into the shift register. When the LE signal is taken high, the data stored in the shift register is transferred to one of latch of them depending upon the control bit data setting.

Table.1 Control Bit

Control bit		Destination of serial data
CN1	CN2	
L	L	The programmable reference counter for the TX-PLL
H	L	The programmable reference counter for the RX-PLL
L	H	The programmable counter and the swallow counter for the TX-PLL
H	H	The programmable counter and the swallow counter for the RX-PLL

Shift Register Configuration

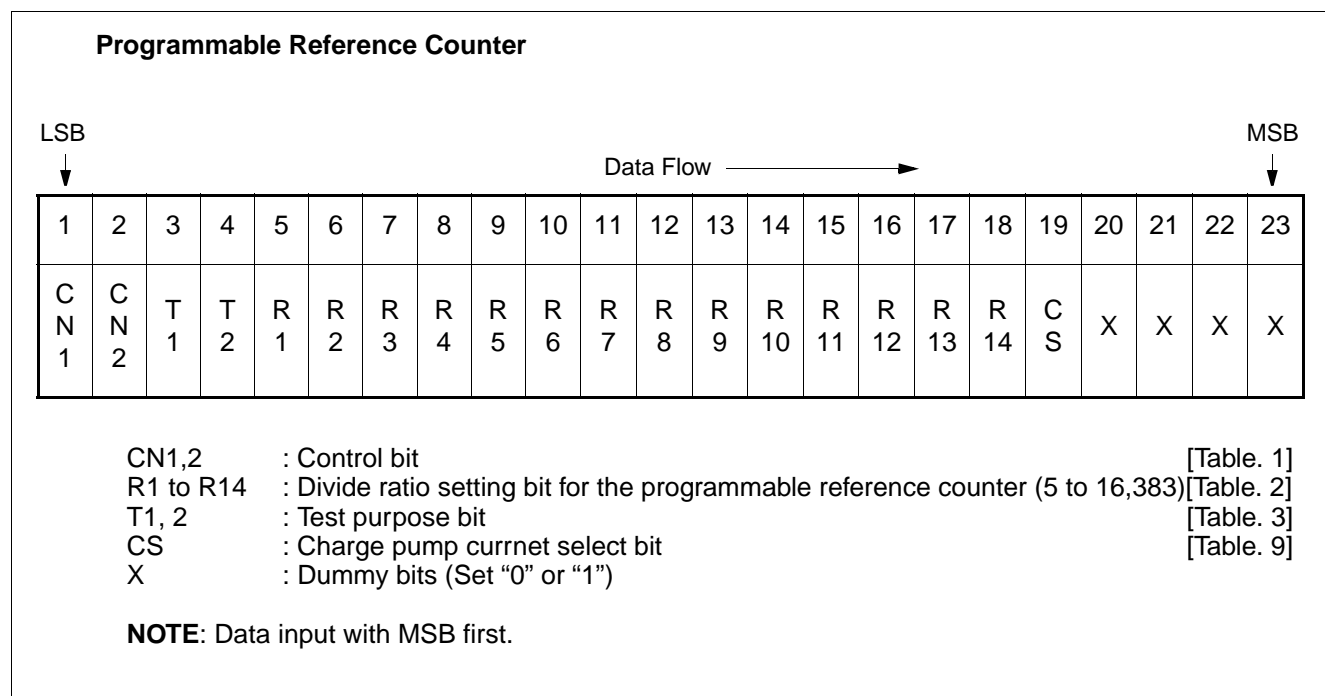

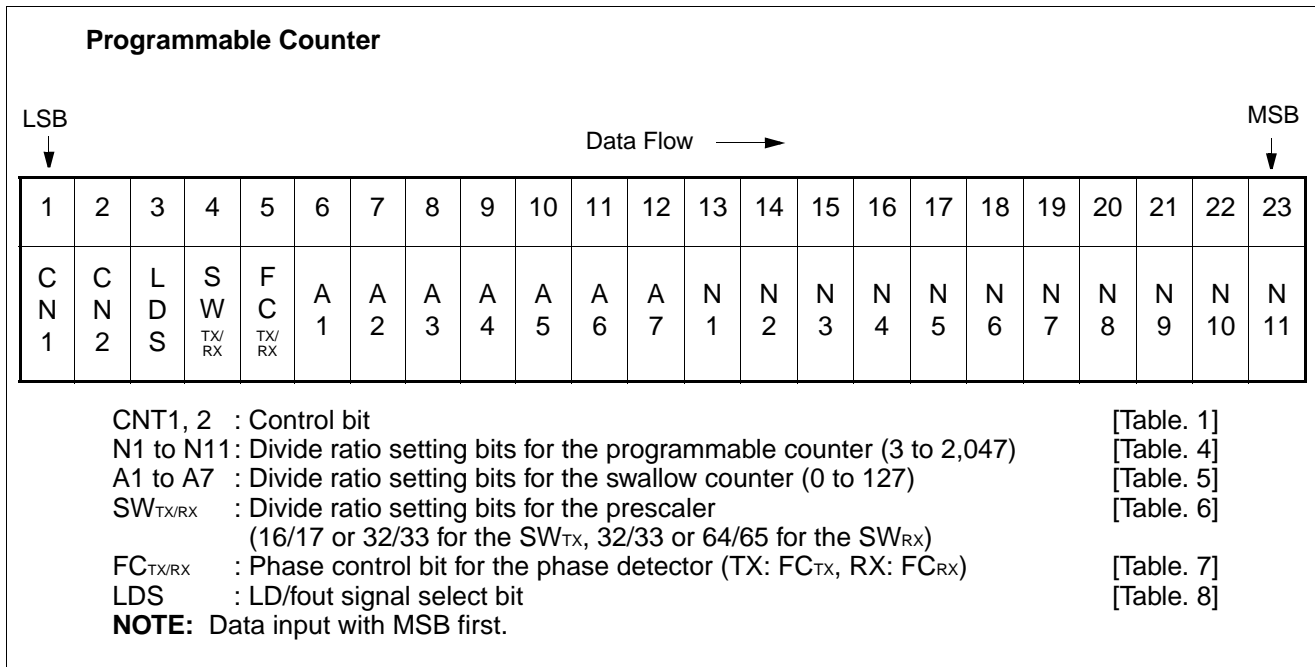

Table2. Binary 14-bit Programmable Reference Counter Data Setting

Divide ratio (R)	R ₁₄	R ₁₃	R ₁₂	R ₁₁	R ₁₀	R ₉	R ₈	R ₇	R ₆	R ₅	R ₄	R ₃	R ₂	R ₁
3	0	0	0	0	0	0	0	0	0	0	0	0	1	1
4	0	0	0	0	0	0	0	0	0	0	0	1	0	0
·	·	·	·	·	·	·	·	·	·	·	·	·	·	·
16383	1	1	1	1	1	1	1	1	1	1	1	1	1	1

Note: Divide ratio less than 3 is prohibited.

Table.3 Test Purpose Bit Setting

T ₁	T ₂	LD/fout pin state
L	L	Outputs fr _{TX}
H	L	Outputs fr _{RX}
L	H	Outputs fp _{TX}
H	H	Outputs fp _{RX}

MB15F08SL

Table.4 Binary 11-bit Programmable Counter Data Setting

Divide ratio (N)	N 11	N 10	N 9	N 8	N 7	N 6	N 5	N 4	N 3	N 2	N 1
3	0	0	0	0	0	0	0	0	0	1	1
4	0	0	0	0	0	0	0	0	1	0	0
·	·	·	·	·	·	·	·	·	·	·	·
2047	1	1	1	1	1	1	1	1	1	1	1

Note: Divide ratio less than 3 is prohibited.

Table.5 Binary 7-bit Swallow Counter Data Setting

Divide ratio (N)	A 7	A 6	A 5	A 4	A 3	A 2	A 1
0	0	0	0	0	0	0	0
1	0	0	0	0	0	0	1
·	·	·	·	·	·	·	·
127	1	1	1	1	1	1	1

Note: Divide ratio (A) range = 0 to 127

Table.6 Prescaler Data Setting

		SW = "H"	SW = "L"
Prescaler divide ratio	TX-PLL	16/17	32/33
	RX-PLL	32/33	64/65

Table.7 Phase Comparator Phase Switching Data Setting

	FC _{TX, RX} = H	FC _{TX, RX} = L
	D _{O_{TX, RX}}	
fr > fp	H	L
fr = fp	Z	Z
fr < fp	L	H
VCO polarity	(1)	(2)

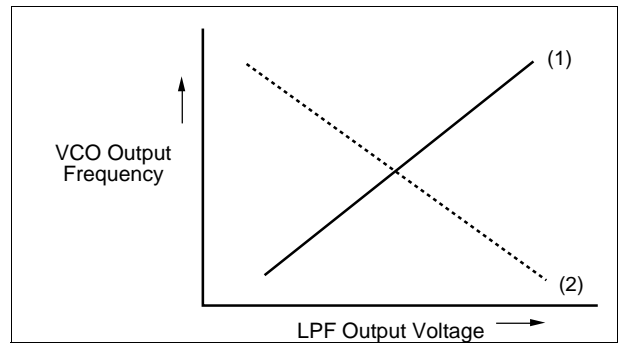

Note: Z = High-impedance
Depending upon the VCO and LPF polarity, FC bit should be set.

Table.8 LD/fout Output Select Data Setting

LDS	LD/fout output signal
H	fout (fr _{TX, RX} , fp _{TX, RX}) signals
L	LD signal

Table.9 Charge Pump Current Setting

CS	Current value
H	±6.0 mA
L	±1.5 mA

Power Saving Mode (Intermittent Mode Control Circuit)

Table.10 PS Pin Setting

PS pin	Status
H	Normal mode
L	Power saving mode

The intermittent mode control circuit reduces the PLL power consumption. By setting the PS pin low, the device enters into the power saving mode, reducing the current consumption. See the Electrical Characteristics chart for the specific value.

The phase detector output, Do, becomes high impedance.

For the dual PLL, the lock detector, LD, is as shown in the LD Output Logic table.

Setting the PS pin high, releases the power saving mode, and the device works normally.

The intermittent mode control circuit also ensures a smooth startup when the device returns to normal operation. When the PLL is returned to normal operation, the phase comparator output signal is unpredictable. This is because of the unknown relationship between the comparison frequency (fp) and the reference frequency (fr) which can cause a major change in the comparator output, resulting in a VCO frequency jump and an increase in lockup time. To prevent a major VCO frequency jump, the intermittent mode control circuit limits the magnitude of the error signal from the phase detector when it returns to normal operation.

- Note: When power (Vcc) is first applied, the device must be in standby mode, PS = Low, for at least 1 μs.
- Note: PS pin must be set "L" for Power-ON.

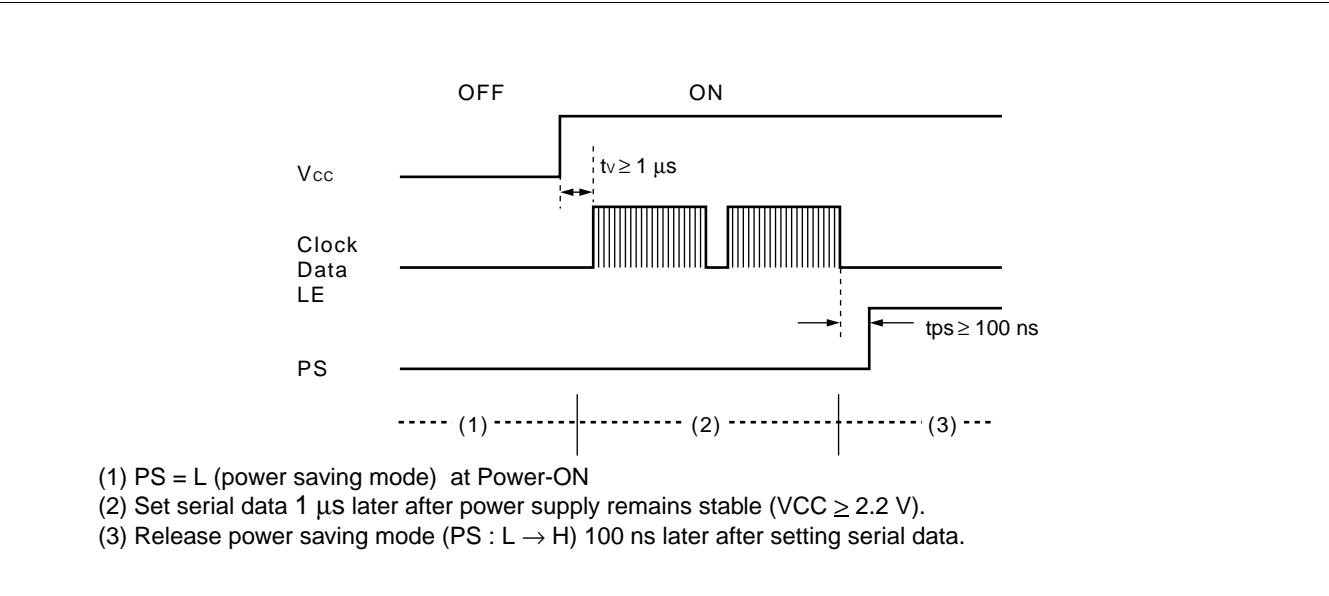

MB15F08SL

■ SERIAL DATA INPUT TIMING

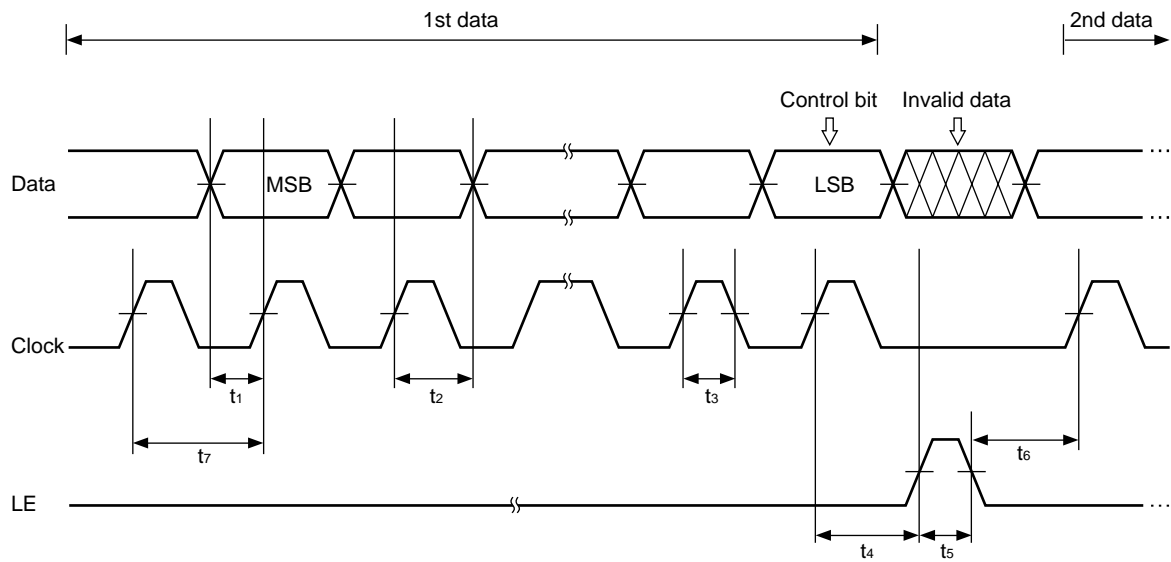

On rising edge of the clock, one bit of the data is transferred into the shift register.

Parameter	Min.	Typ.	Max.	Unit
t1	20	–	–	ns
t2	20	–	–	ns
t3	30	–	–	ns
t4	30	–	–	ns

Parameter	Min.	Typ.	Max.	Unit
t5	100	–	–	ns
t6	20	–	–	ns
t7	100	–	–	ns

Note: LE should be “L” when the data is transferred into the shift register.

■ PHASE COMPARATOR OUTPUT WAVEFORM

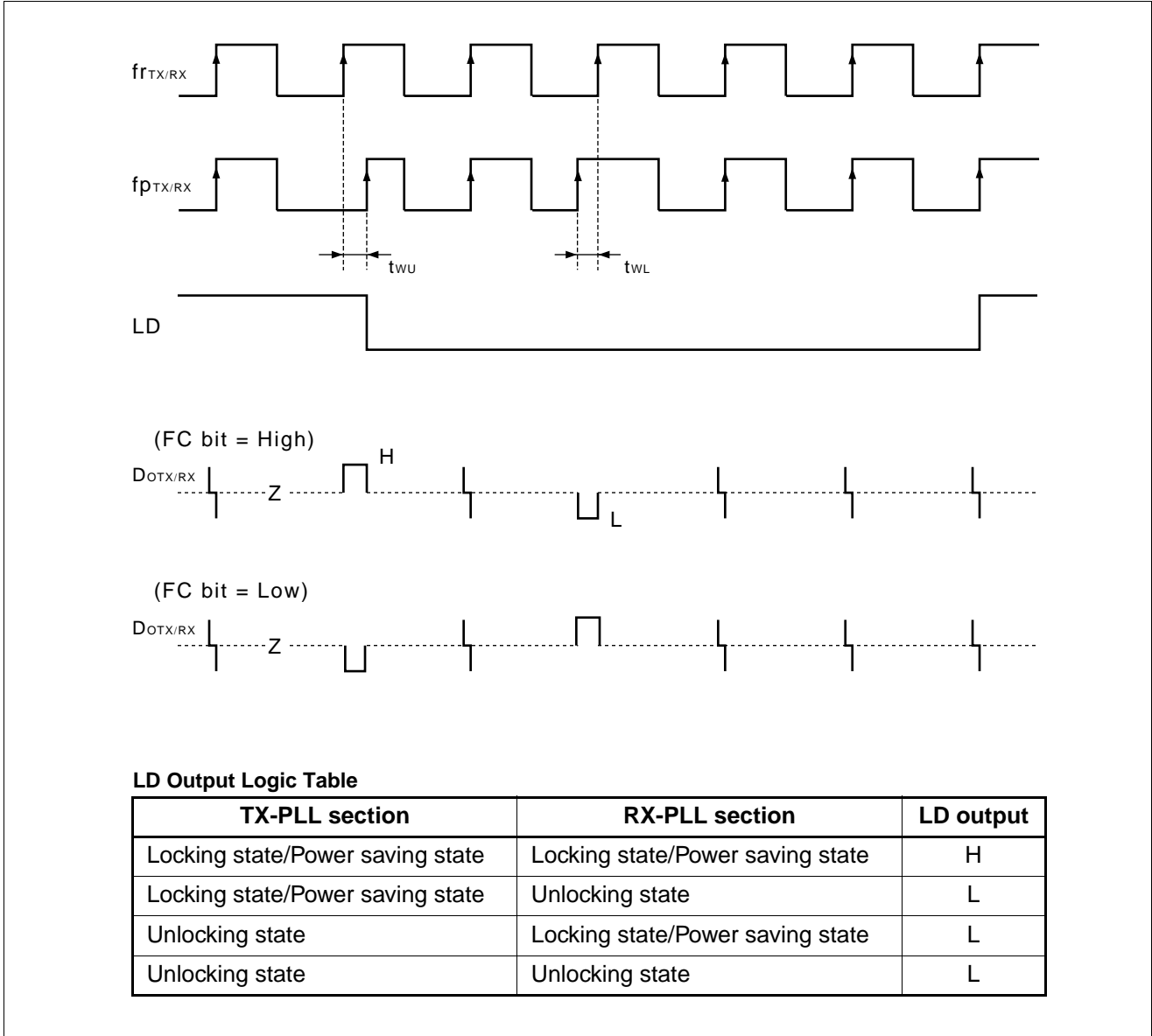

- Notes:
- Phase error detection range = -2π to $+2\pi$
 - Pulses on $DOTX/RX$ signals are output to prevent dead zone.
 - LD output becomes low when phase error is t_{WU} or more.
 - LD output becomes high when phase error is t_{WL} or less and continues to be so for three cycles or more.
 - t_{WU} and t_{WL} depend on OSC_{in} input frequency as follows.
 $t_{WU} \geq 2/f_{osc}$: i. e. $t_{WU} \geq 156.3$ ns when $f_{osc} = 12.8$ MHz
 $t_{WL} \leq 4/f_{osc}$: i. e. $t_{WL} \leq 312.5$ ns when $f_{osc} = 12.8$ MHz

MB15F08SL

MEASUREMENT CIRCUIT (for Measuring Input Sensitivity fin/OSCin)

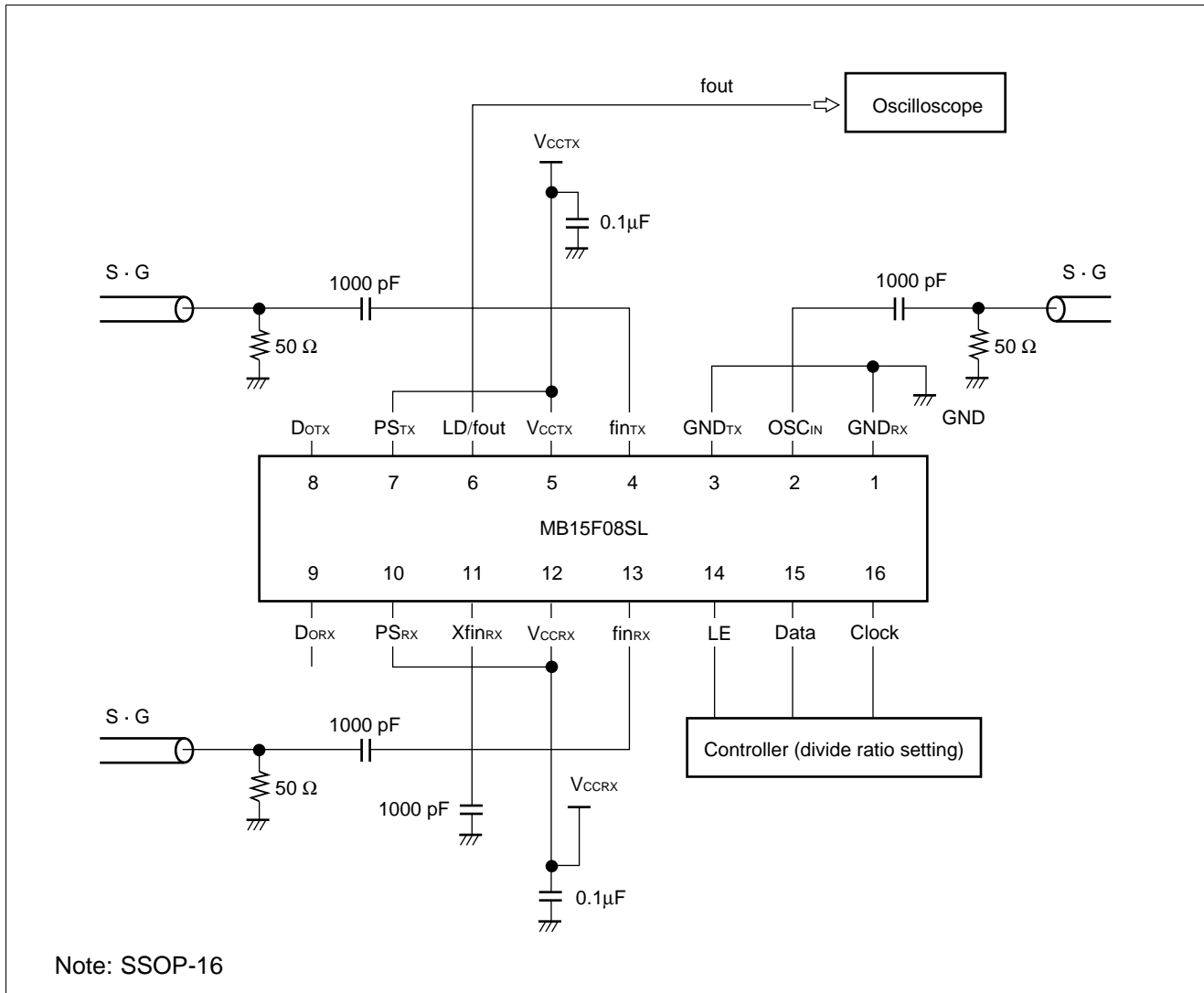

■ TYPICAL CHARACTERISTICS

1. fin input sensitivity

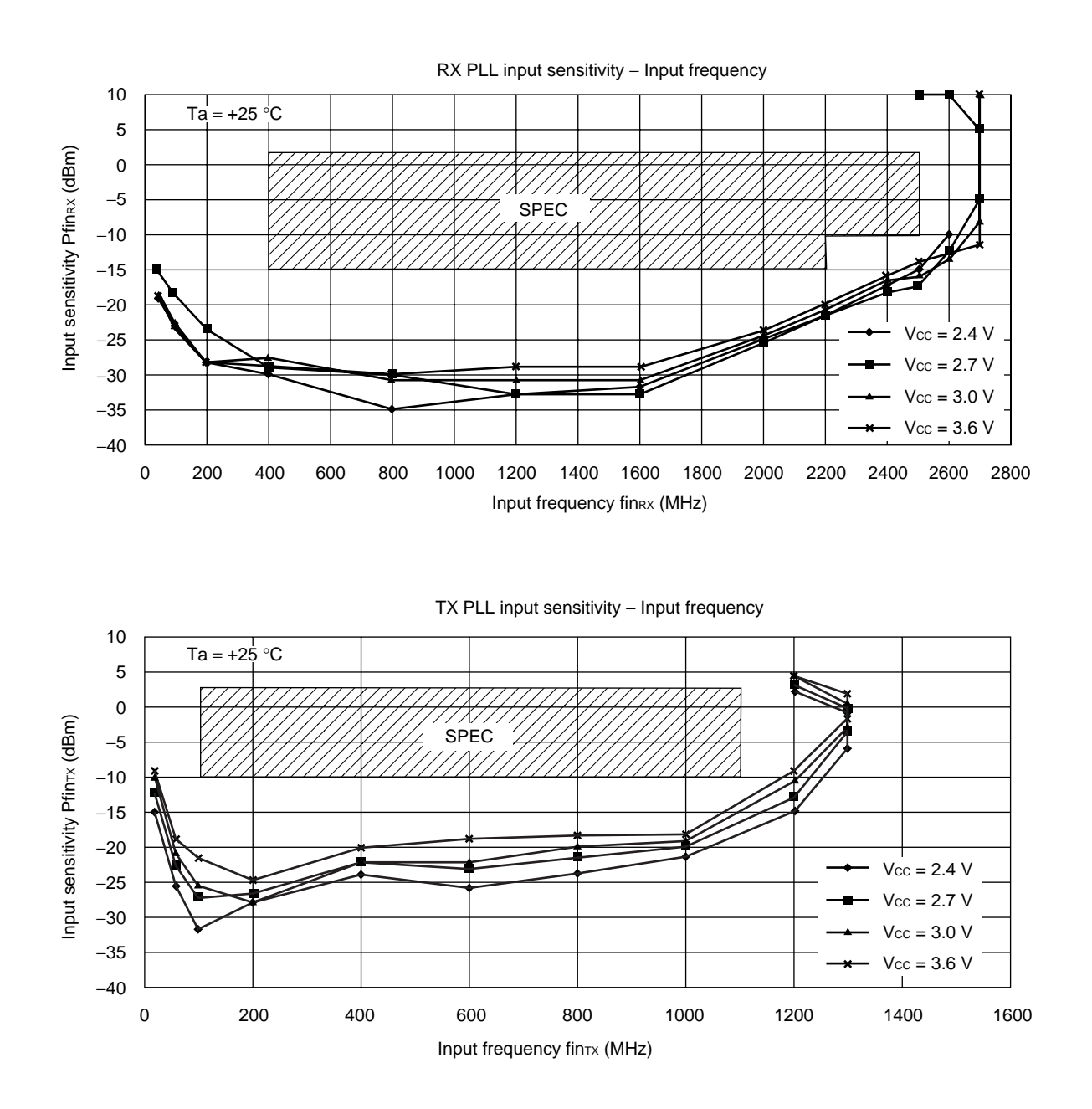

MB15F08SL

2. OSC_{IN} input sensitivity

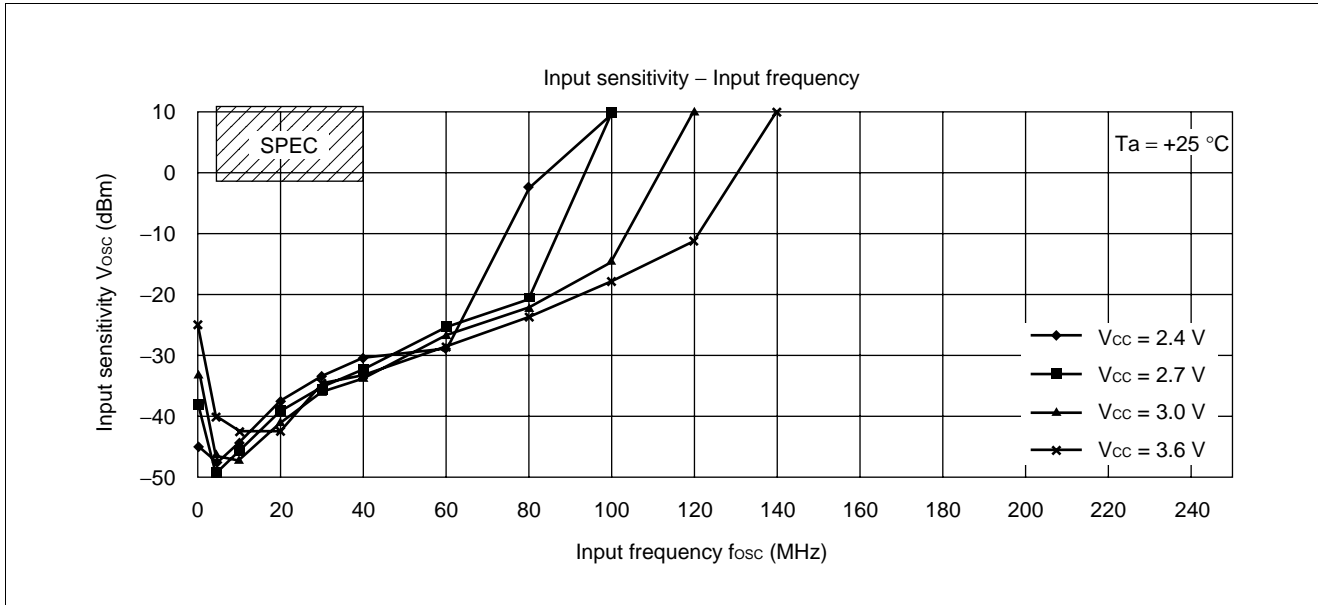

3. Do output current (RX PLL)

1.5 mA mode

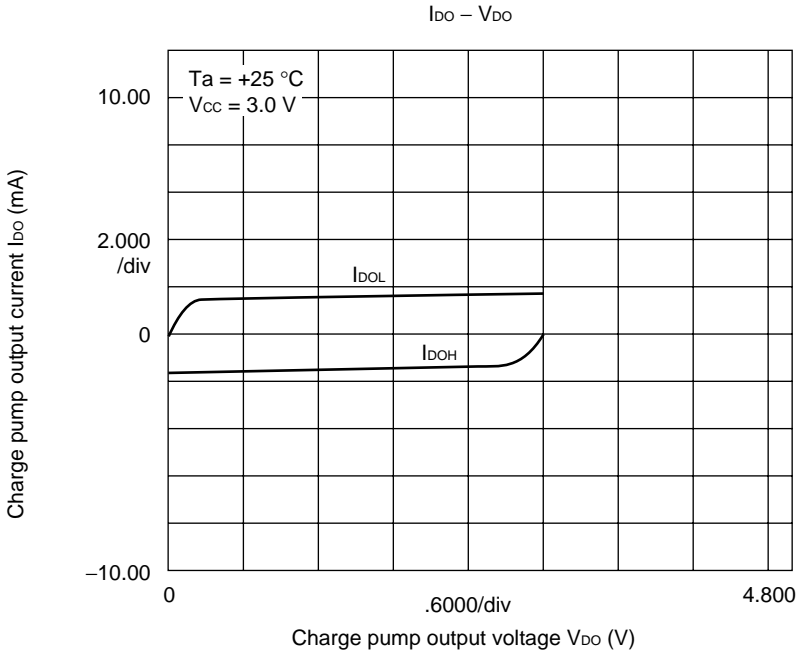

6.0 mA mode

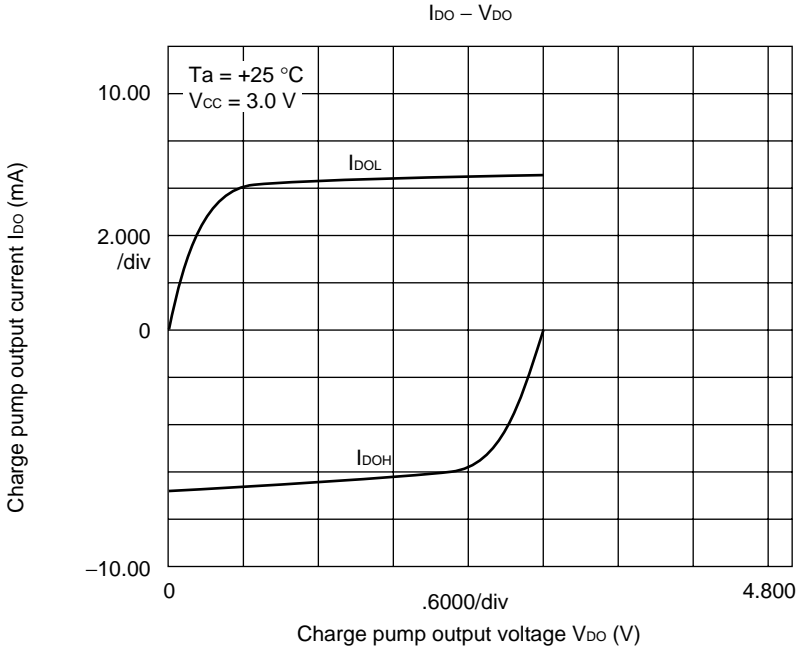

MB15F08SL

4. Do output current (TX PLL)

1.5 mA mode

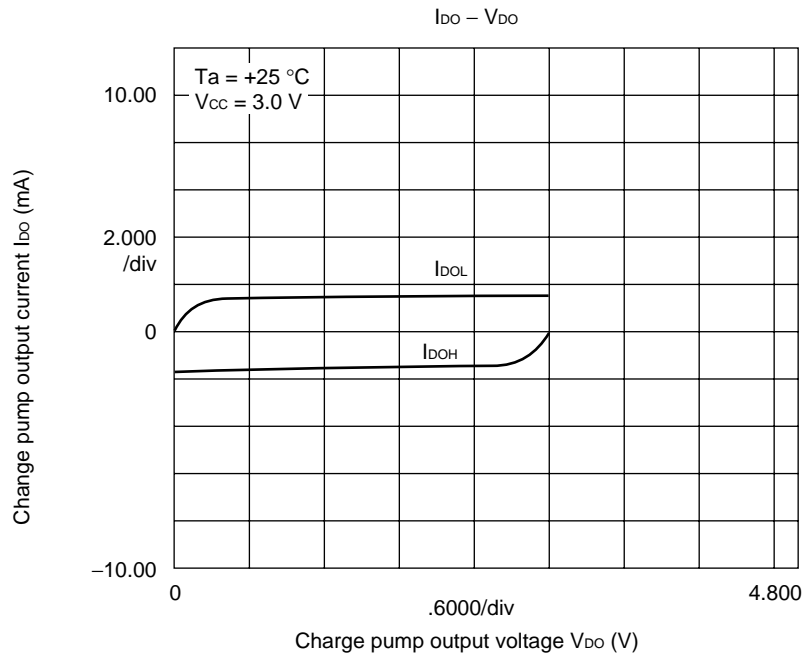

6.0 mA mode

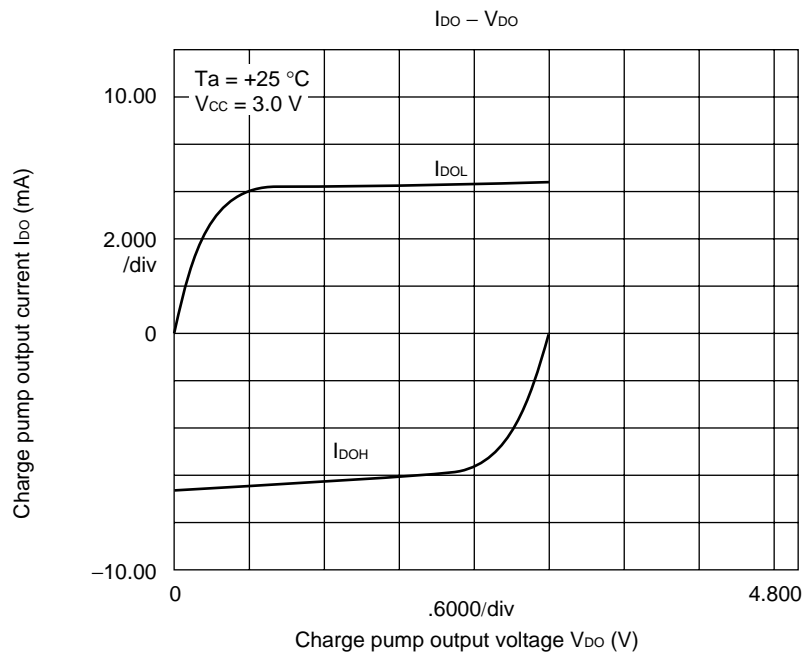

5. fin input impedance

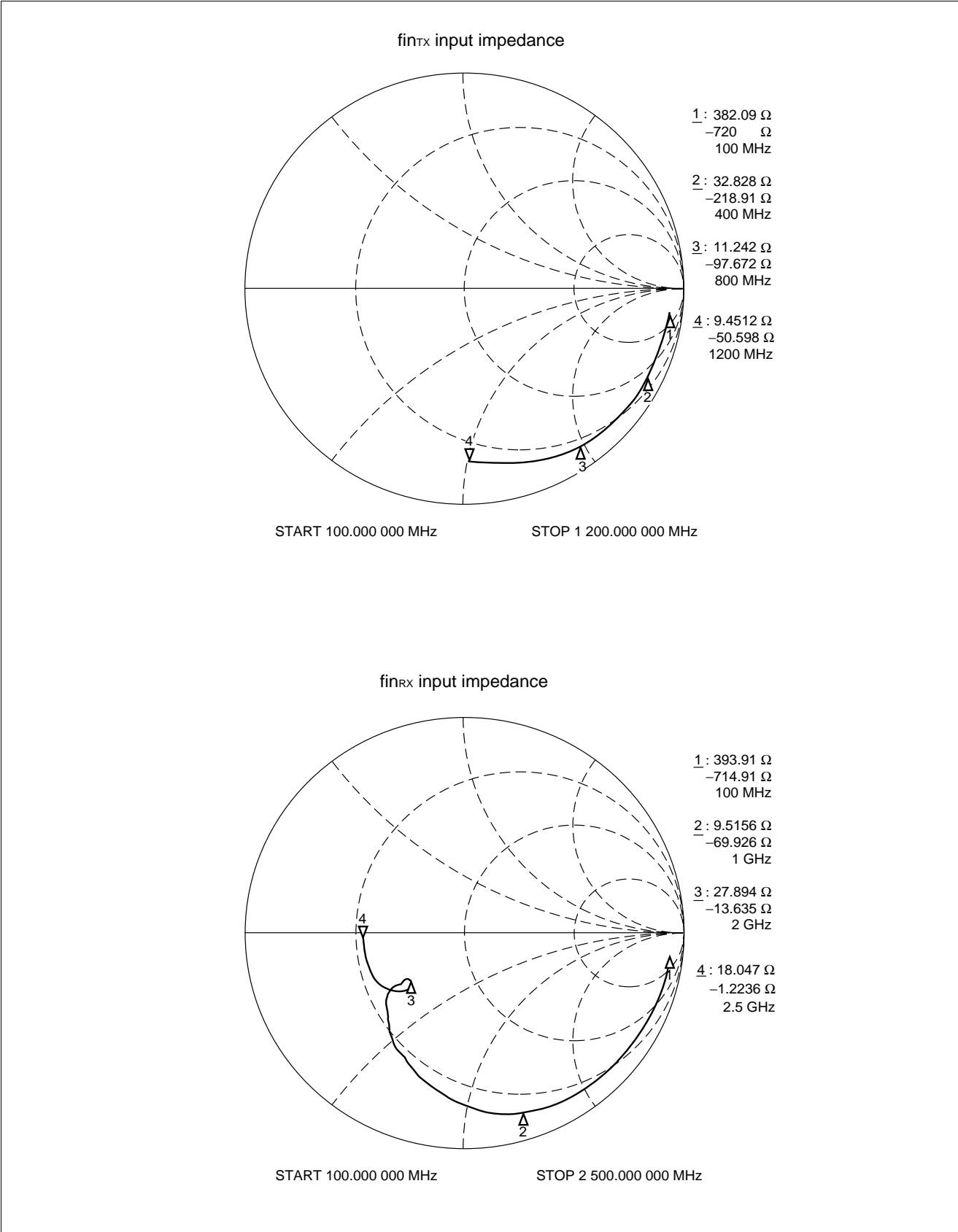

MB15F08SL

6. OSC_{IN} input impedance

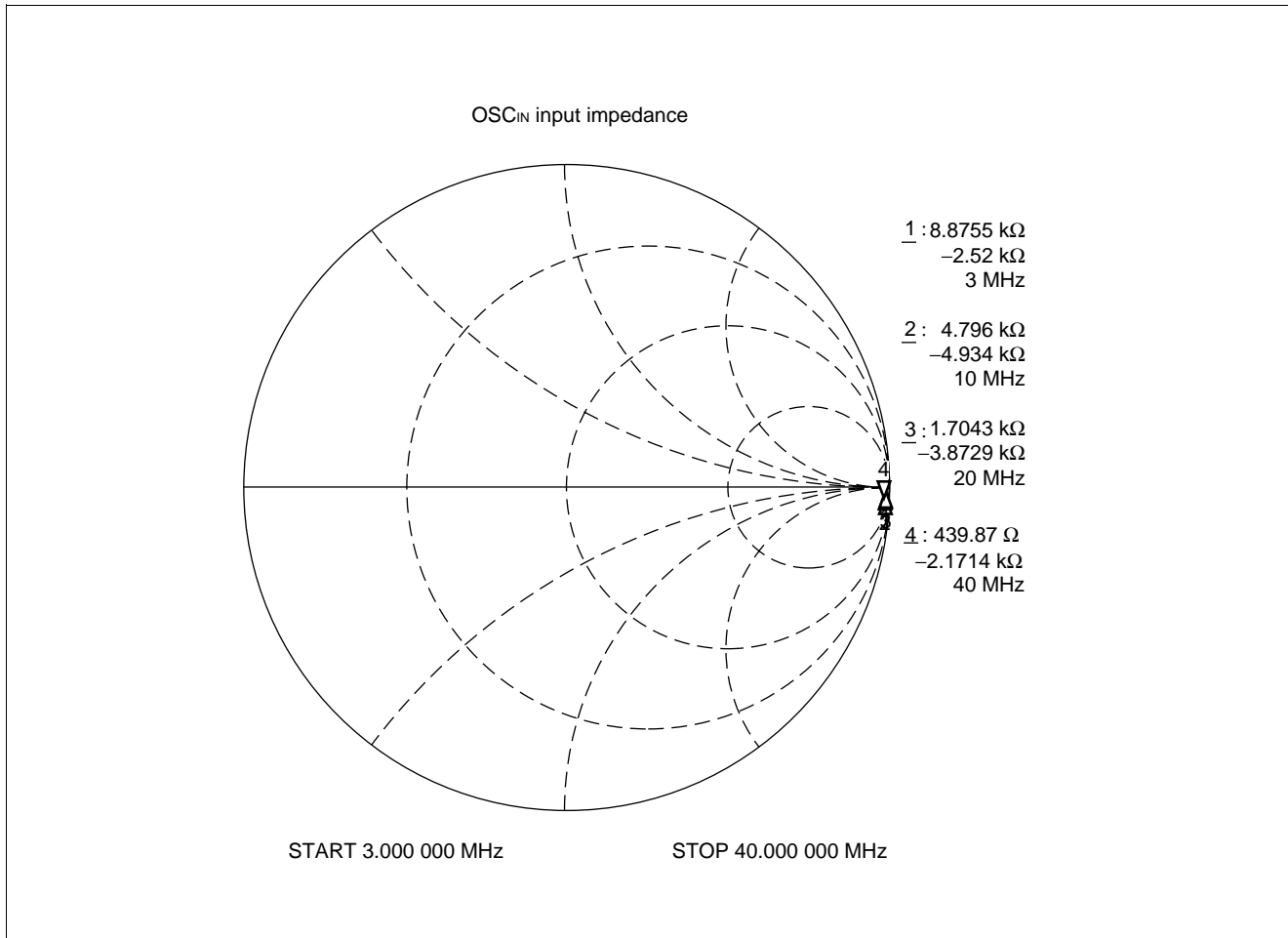

REFERENCE INFORMATION

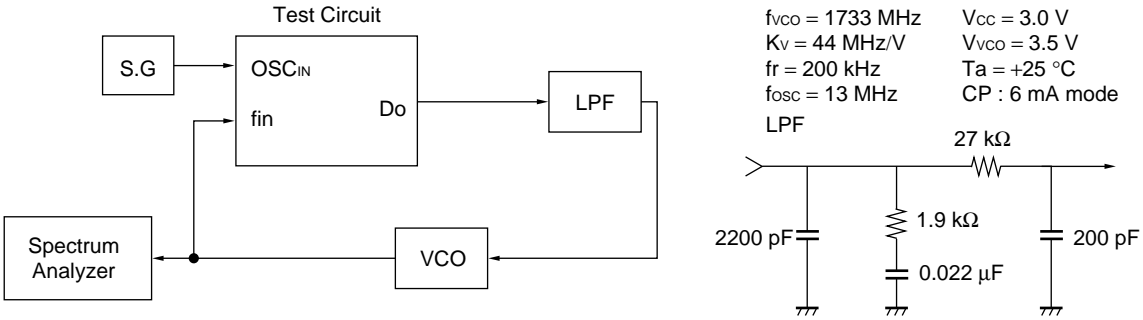

PLL Reference Leakage

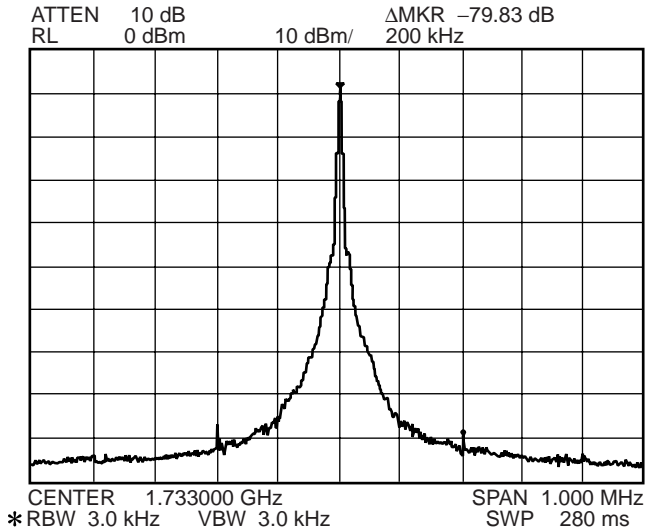

PLL Phase Noise

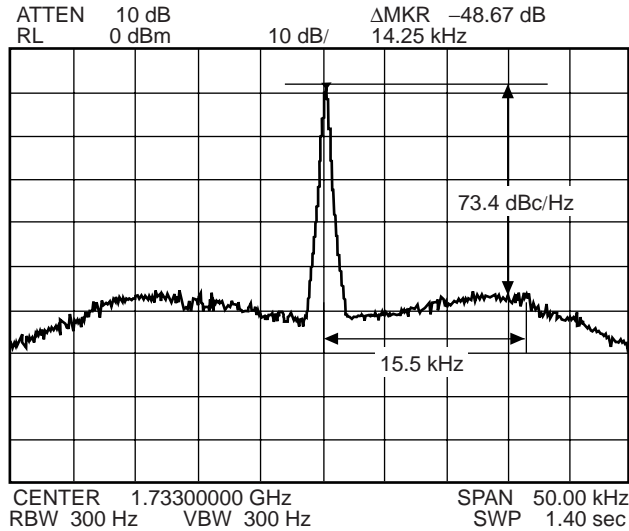

MB15F08SL

(Continued)

PLL Lock Up time

1733 MHz → 1803 MHz within ± 1 KHz
Lch → Hch
467 μs

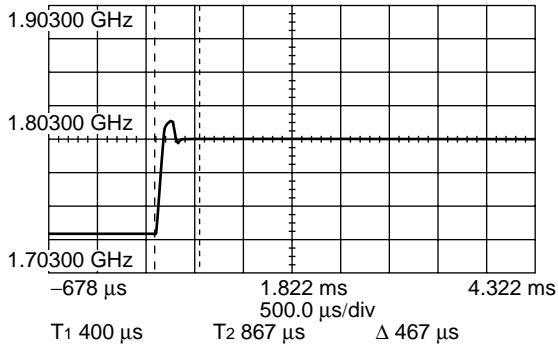

PLL Lock Up time

1803 MHz → 1733 MHz within ± 1 KHz
Hch → Lch
467 μs

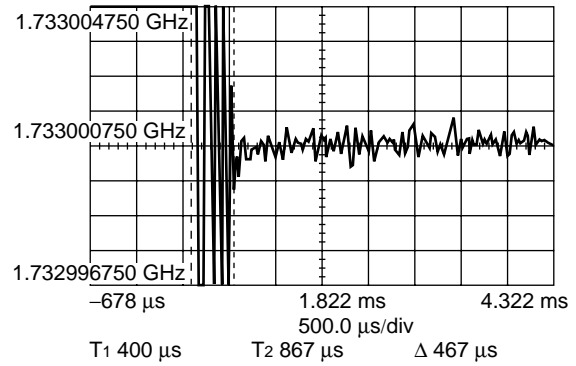
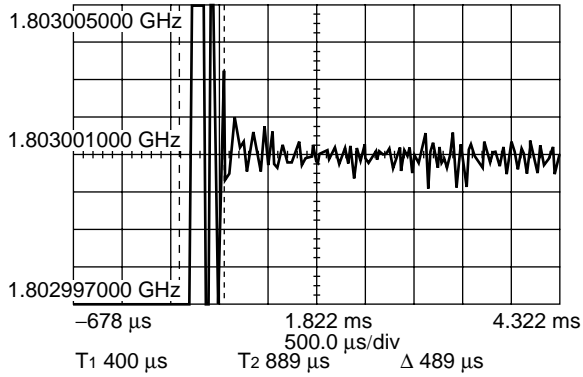
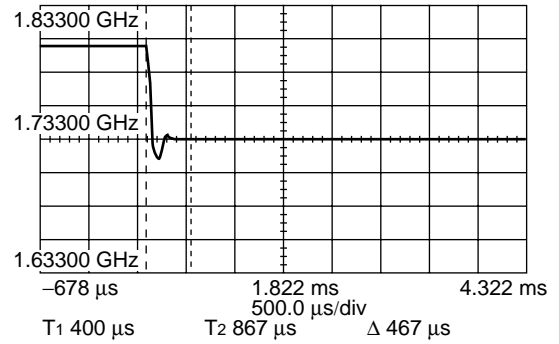

APPLICATION EXAMPLE

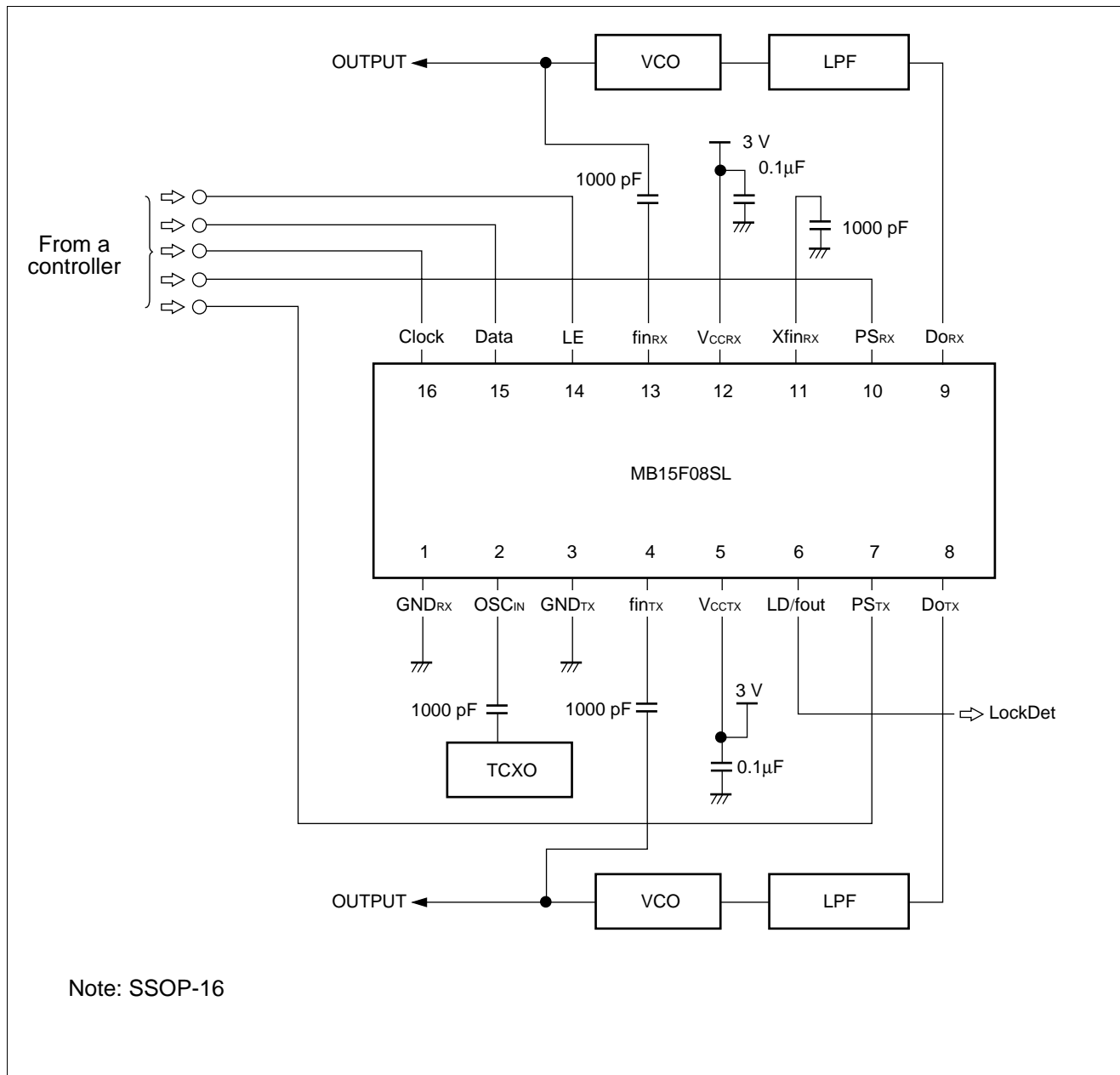

USAGE PRECAUTIONS

- (1) $V_{CCR\ X}$ must equal $V_{CC\ TX}$.
Even if either RX-PLL or TX-PLL is not used, power must be supplied to both $V_{CCR\ X}$ and $V_{CC\ TX}$ to keep them equal. It is recommended that the non-use PLL is controlled by power saving function.
- (2) To protect damage by electrostatic discharge, note the following handling precautions:
 - Store and transport devices in conductive containers.
 - Use properly grounded workstations, tools, and equipment.
 - Turn off power before inserting or removing this device into or from a socket.
 - Protect leads with conductive sheet, when transporting a board mounted device.

MB15F08SL

■ ORDERING INFORMATION

Part number	Package	Remarks
MB15F08SLPFV1	16-pin, plastic SSOP (FPT-16P-M05)	
MB15F08SLPV1	16-pad, plastic BCC (LCC-16P-M04)	

PACKAGE DIMENSIONS

16-pin, Plastic SSOP
(FPT-16P-M05)

* : These dimensions do not include resin protrusion.

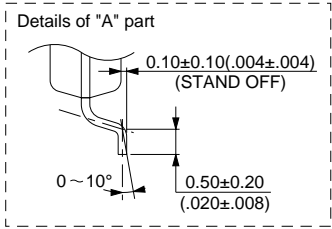
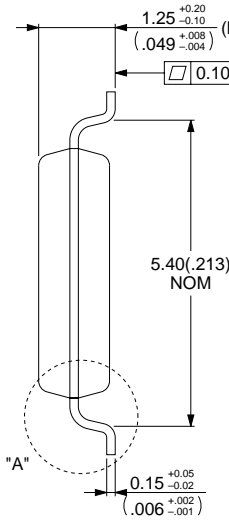
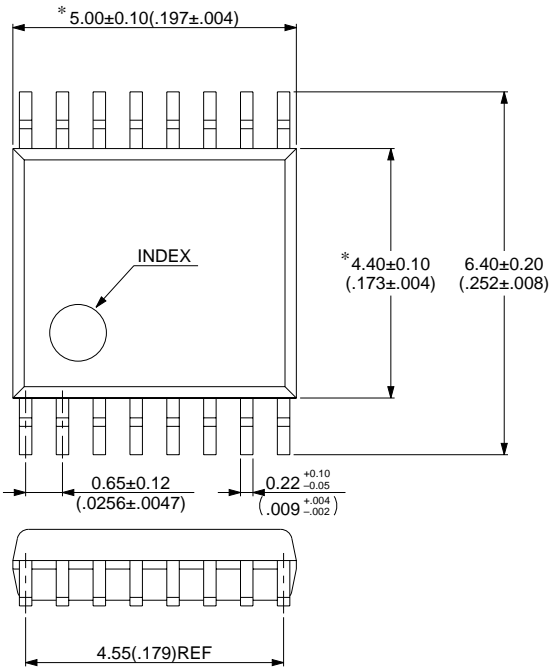

© 1994 FUJITSU LIMITED F16013S-2C-4

Dimensions in mm (inches)

(Continued)

MB15F08SL

(Continued)

16-pad, Plastic BCC
(LCC-16P-M04)

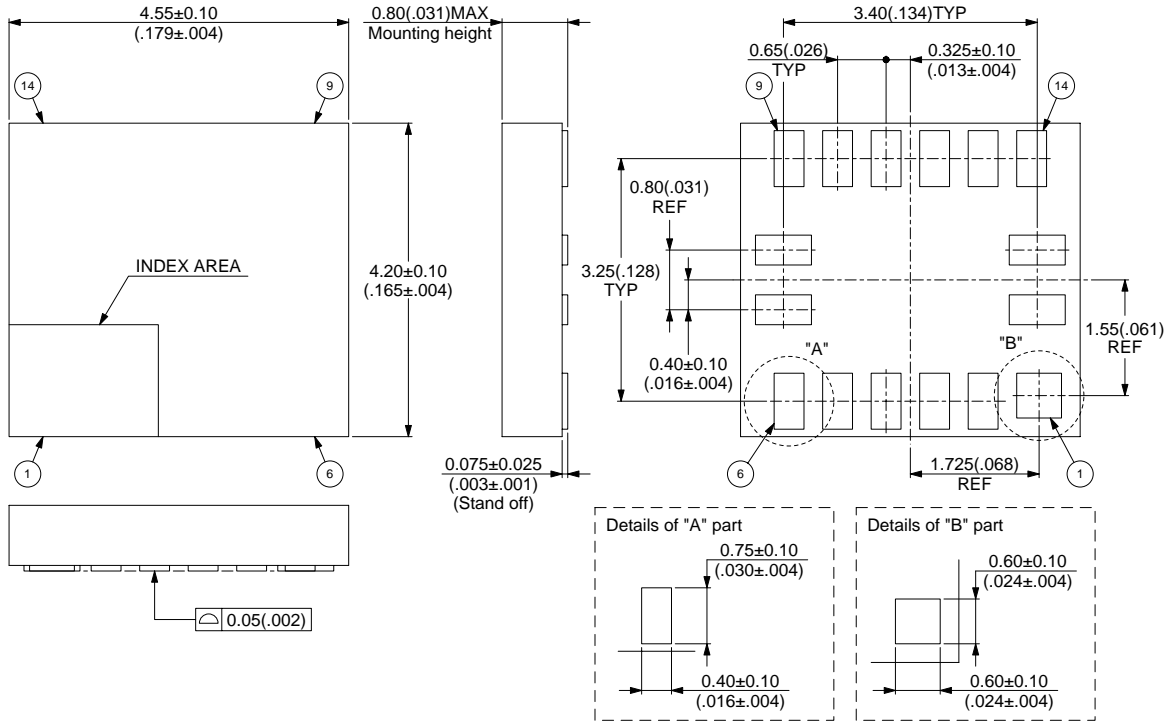

© 1999 FUJITSU LIMITED C16015S-1C-1

Dimensions in mm (inches)

FUJITSU LIMITED

For further information please contact:

Japan

FUJITSU LIMITED
Corporate Global Business Support Division
Electronic Devices
KAWASAKI PLANT, 4-1-1, Kamikodanaka
Nakahara-ku, Kawasaki-shi
Kanagawa 211-8588, Japan
Tel: 81(44) 754-3763
Fax: 81(44) 754-3329

<http://www.fujitsu.co.jp/>

North and South America

FUJITSU MICROELECTRONICS, INC.
Semiconductor Division
3545 North First Street
San Jose, CA 95134-1804, USA
Tel: (408) 922-9000
Fax: (408) 922-9179

Customer Response Center
Mon. - Fri.: 7 am - 5 pm (PST)
Tel: (800) 866-8608
Fax: (408) 922-9179

<http://www.fujitsumicro.com/>

Europe

FUJITSU MIKROELEKTRONIK GmbH
Am Siebenstein 6-10
D-63303 Dreieich-Buchsschlag
Germany
Tel: (06103) 690-0
Fax: (06103) 690-122

<http://www.fujitsu-edc.com/>

Asia Pacific

FUJITSU MICROELECTRONICS ASIA PTE LTD
#05-08, 151 Lorong Chuan
New Tech Park
Singapore 556741
Tel: (65) 281-0770
Fax: (65) 281-0220

<http://www.fmap.com.sg/>

F9904

© FUJITSU LIMITED Printed in Japan

All Rights Reserved.

The contents of this document are subject to change without notice. Customers are advised to consult with FUJITSU sales representatives before ordering.

The information and circuit diagrams in this document are presented as examples of semiconductor device applications, and are not intended to be incorporated in devices for actual use. Also, FUJITSU is unable to assume responsibility for infringement of any patent rights or other rights of third parties arising from the use of this information or circuit diagrams.

FUJITSU semiconductor devices are intended for use in standard applications (computers, office automation and other office equipment, industrial, communications, and measurement equipment, personal or household devices, etc.).

CAUTION:

Customers considering the use of our products in special applications where failure or abnormal operation may directly affect human lives or cause physical injury or property damage, or where extremely high levels of reliability are demanded (such as aerospace systems, atomic energy controls, sea floor repeaters, vehicle operating controls, medical devices for life support, etc.) are requested to consult with FUJITSU sales representatives before such use. The company will not be responsible for damages arising from such use without prior approval.

Any semiconductor devices have an inherent chance of failure. You must protect against injury, damage or loss from such failures by incorporating safety design measures into your facility and equipment such as redundancy, fire protection, and prevention of over-current levels and other abnormal operating conditions.

If any products described in this document represent goods or technologies subject to certain restrictions on export under the Foreign Exchange and Foreign Trade Law of Japan, the prior authorization by Japanese government will be required for export of those products from Japan.